



This range of vertical air-water heat exchanger, PWS, with a IP 55 protection degree, is ideal for dusty environments with high temperatures. Air cleanliness and the temperature around the enclosure will not affect the heat exchanger's performance. Several sizes of the heat exchanger are available, making the choice of the most optimum heat exchanger easy.

Description: For vertical installation. Additional work is not required to the cutout to guarantee the IP. Integrated thermostat and solenoid valve for temperature control, and temperature monitoring with alarm contact. The thermostat is adjustable between 8 °C and 50 °C, factory setting 35 °C. Maximum permissible operating pressure of 10 bar. The cooling capacity for specific conditions are indicated in the diagrams. Water inlet temperature between 1 °C up to 35 °C.

Type of connection: Spring-type terminal included with plug for electrical connection, 13 mm hose nozzle for water pipe connections.

Material: Housing made of galvanized steel powder coated. Heat exchanger manufactured from copper pipe, with aluminium fins.

Ambient temperature range: +1 °C to +70 °C.

Protection: IP 55 towards the electrical enclosure.

Finish: RAL 7035.

Pack quantity: One unit.

IP 55



PWS7062R5

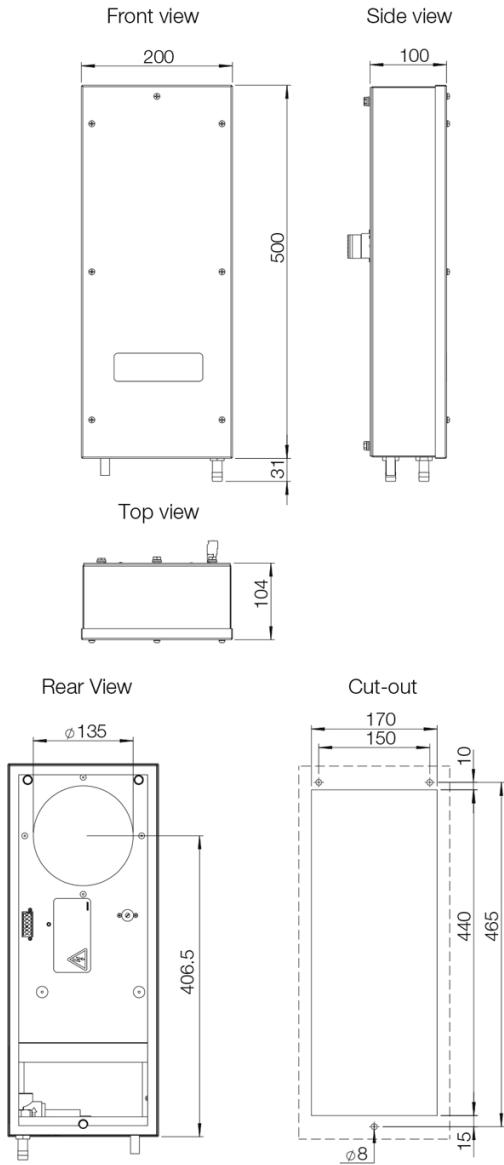

PWS7102R5

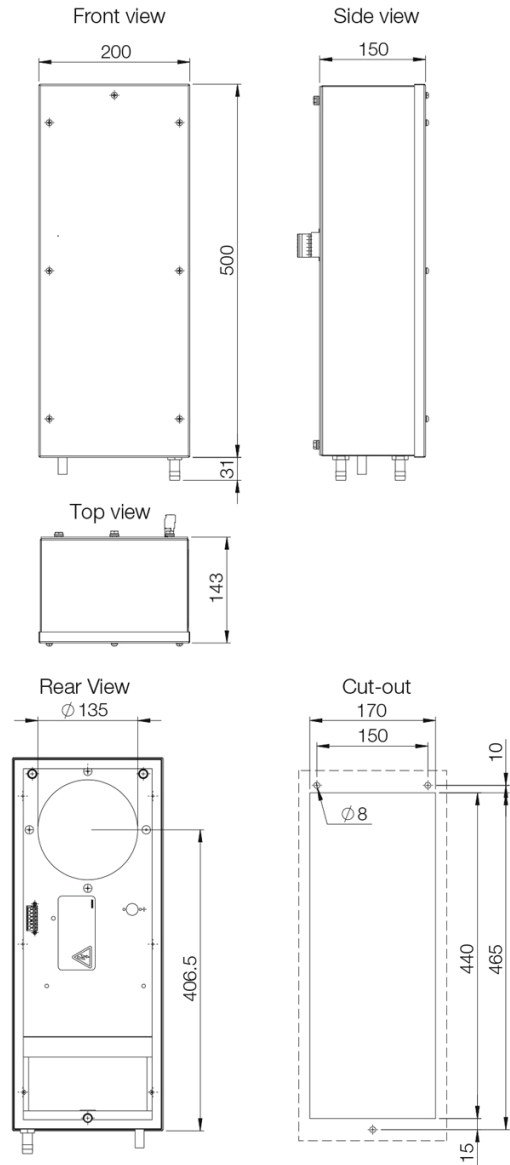

Performance

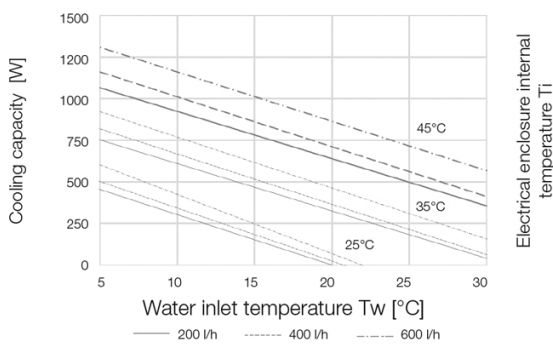

Performance

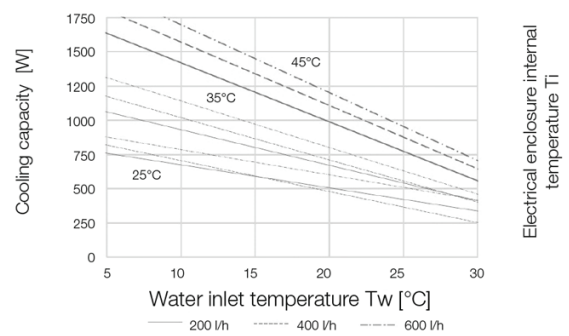

H	W	D		Power W10/ A35 (W)		Pre fuse T (A)				Noise (dB)	Frequency (Hz)	Weight (kg)	Item no.
500	200	100	600	68 / 70	0.35 / 0.38	4	1.50 / 1.80	440	230V	≤48	50 / 60	6.65	PWS7062R5
500	200	150	950	82 / 84	0.35 / 0.40	4	1.70 / 1.95	570	230V	≤48	50 / 60	8.33	PWS7102R5
950	400	115	1500	125 / 182	0.55 / 0.75	4	2.00 / 2.00	850	230V	53	50 / 60	23.33	PWS7152R5
950	400	190	3150	295 / 385	1.30 / 1.70	6	5.80 / 6.60	1670	230V	54	50 / 60	25.56	PWS7332R5

PWS

Air / Water heat exchanger



HOFFMAN

CONNECT AND PROTECT