

Data Sheet

Refrigeration Controller

ETC 1H



Introduction

The ETC 1H is introducing a flexible platform due to onboard micro-controller and software dedicated product configuration, perfect for light commercial refrigeration applications. Standard versions with similar functionality as the traditional electro-mechanical thermostats as well as several customized high performance software versions for various applications are available.

The ETC 1H is developed for applications such as:

- Refrigerators
- Bottle coolers
- Ice banks
- Freezers
- Street coolers
- No-frost freezers with heating element
- Medicine coolers
- Wine, cake and chocolate coolers

Features

- ETC 1H can control the cabinet temperature directly
- ETC 1H has low energy consumption
- 1 or 2 sensors (Air, evaporator) and optional remote display can be connected
- Using NTC temperature sensors
- Temperature control independent of barometric pressure
- High accuracy combined with close differentials and narrow tolerances ensures improved control
- Built in timers enhances functionality
- Optional alarm for over or under temperature in both cold and warm
- Auxiliary relays: 5 Amp for heater, fan, light etc. Eventually with delayed start or/and stop
- Under voltage and over voltage compressor protection (brown-out protection)
- Pressure equalisation protection on starting the device or when voltage drops out (blackout protection)
- Diagnostics and self check of sensors and potentiometer
- Several defrosting methods can be handled:
 - Time controlled defrosting
 - Time controlled defrosting with evaporator sensor
 - Temperature controlled defrosting
- Dual band control of outdoor bottle coolers
- Quick Parameter Programming using PC software tool and Gateway
- Production Programming using docking station

Approvals



Technical data

		120V, 60Hz	230V, 50/60Hz
Power supply		115 V a.c. +/- 10% 60 Hz	220 V a.c. -240 V d.c +/- 10% 50 Hz
Energy consumption		Max 0.5 Watt	Max 0.5 Watt
Operating conditions	Ambient temp.	32°F to +122°F	0°C to 50°C
	Humidity	Max 90% RH, Non-condensing	Max 90% RH, Non-condensing
Measuring range	NTC sensor	-40°F to 185°F	-40°C to 85°C
Relay output 1	Compressor	UL 60730: LRA96, FLA16	IEC/EN 60730: 16(16) A UL 60730: LRA 60/ FLA 10
Relay output 2	Heater	5 A	5 A
Relay output 3	Fan	UL 60730: LRA 6/ FLA1	IEC/EN 60730: 5 A UL 60730: LRA 6/ FLA 1
Accuracy	NTC sensor	+/- 1 K	+/- 1 K
	ETC1H	+/- 0.5 K	+/- 0.5 K
Temperature sensors		NTC- 5K	NTC- 5K
Life time	Relay 1	+350,000 cycles	+350,000 cycles
	Relay 2	+30,000 cycles	+30,000 cycles
	Relay 3	+30,000 cycles	+30,000 cycles
Connections	Power	6.3 mm x 0.8 mm tabs, RAST 5	6.3 mm x 0.8 mm tabs, RAST 5
	Signal/remote	3-pole RAST 2,5 edge connector 2-Pole RAST 2,5 edge connector	3-pole RAST 2,5 edge connector 2-Pole RAST 2,5 edge connector
Temperature indication		Through optional remote display	Through optional remote display
Approvals		UL-C, NSF	Semko, CE, CQC, EAC
EMC Category		-----	Category-1
IP class		IP 00	IP 00
Remote control		Optional remote display with Control. 1-wire protocol	Optional remote display with Control. 1-wire protocol
Number of sensors		2 (optional 3)	2 (optional 3)
Start-up-time		< 2 seconds	< 2 seconds

Functionality

(All functions are optional)

Temperature	Settings	Differential: -1-10 K, Range: 0-30 K, Defrost: 0°C-10°C
	Adjustment	Knob with stop 210° +/-5°. Stop 45° +/-5° o Knob angle without stop 255° +/-5°
Diagnostics	Visual indication	On-board LED (Red)
	Function	Self check of sensors and potentiometer
	Sensor fault	Air sensor
Compressor protection	Brown-out Black-out	Under-voltage and over-voltage protection Based on temperature at cabinet sensor
Defrost	Mode 1	Start by Time- Stop by Cabinet Temperature (1 sensor)
	Mode 2	Start by Time- Stop by Defrost Sensor (2 sensors) Start and Stop by Defrost Sensor (2 sensors)
	Mode 3	Start by Time- Stop by Defrost Sensor (2 sensors)
Alarm	Types	Over or/and under temperature in cold or warm
	Indication	Flashing LED on the ETC 1H or by an external connected remote module or optionally to one of the relays to control a buzzer
Blocked condenser <i>On customer request only</i>	Function	Monitor the condenser temperature and stop the compressor until the temperature goes below the condenser warning temperature
	Indication	Flashing LED on the ETC 1H or by an external connected remote module or optionally to one of the relays to control a buzzer

Parameters

For customized ETC 1H versions to suit individual application needs, it is possible to adjust the following parameters in the controller using Danfoss PC software tool "KoolProg" and Gateway device "KoolKey" with connection cable.
Production level programming is possible with Danfoss KoolDock.

For more information please visit:

<http://refrigerationandairconditioning.danfoss.com/support-center/apps-and-software/koolprog/#/>

Introduction

Parameter		Min	Max	Default	Unit
Thermostat	Cold cut-out	-65.00	+50.00	0.00	°C
	Warm cut-out	-65.00	+50.00	10.00	°C
	Default temp set also used as remote setpoint	0	1023	512	0: cold 1023: warm
	Cold differential	-1.00	+20.00	1.00	K
	Warm differential	-1.00	+20.00	1.00	K
Compressor	Min runtime	0	1800	300	Sec
	Min stoptime	0	1800	300	Sec
	Max runtime	0	10800	3600	Sec
	Max stoptime	0	10800	5400	Sec
	Error runtime	0	1800	600	Sec
	Error Stoptime	0	1800	900	Sec
	Functions flag: D8: Max run time D9: Max stop time	0 0	1 1	0 0	
Alarm on relay	Cold overtemp alarm	-65.00	+50.00	15.00	°C
	Warm overtemp alarm	-65.00	+50.00	15.00	°C
	Cold undertemp alarm	-65.00	+50.00	2.00	°C
	Warm undertemp alarm	-65.00	+50.00	2.00	°C
	Alarm delay	0	120	60	Min
Function flag: D0: Alarm undertemperature D1: Alarm overtemperature	0 0	1 1	0 0		
Defrost	Defrost method: 0: No defrost 1: Time start, Control T stop 2: Time start, Evap T stop 3: Evap T start , Evap T stop	0	3	0	Num
	Defrost terminate temperature	0	+50.00	5.00	°C
	Defrost start temperature	-25.00	0.00	-10.00	°C
	Drip-off time	0	1800	0	Sec
	Minimum defrost time	0	3600	900	Sec
	Maximum defrost time	0	7200	1800	Sec
	Minimum defrost interval	0	720	360	Min
	Maximum defrost interval	0	2160	720	Min
	Function flag: D2: Fan on during defrost D3: Hot-gas defrost D11: Timer reset on cutout	0 0 0	1 1 1	0 0 0	
	Fan	Fan start delay	0	1800	0
Fan stop delay		0	1800	0	Sec
Function flag: D4: Fan stop on cutout		0	1	0	
Blocked condenser	Condenser warning temperature	+50.00	+85.00	70.00	°C
	Condenser stop temperature	+50.00	+85.00	80.00	°C
	Function flag: D7: Condenser watch	0	1	0	
Voltage protection	Minimum cut-in voltage	80	210	185	Vrms
	Voltage threshold	0	20	15	Vrms
	Maximum cut-in voltage	130	264	260	Vrms
	Function flag: D6: Voltage protect	0	1	0	
Miscellaneous	Function flags (see def in each section)				Num
	Factory test	0	65535	0	Boolean
	D0: Comp relay D1: Fan relay D2: Heater relay D6: LED 1/10 blinking D7: LED _ blinking D15: Factory test				
	Sensor Type 0: Epcos 1: Shibaura Zero-cross switching	-100	100	Epcos 0	Num % of 1/4 period
	Thermostat ID low D0-32	0	232	0	Num
	Typenumber	0	10000	0	Num
	D14-15 group number				
	D0-13 number				
	SW version	0	999	100	
	Function flag: D10: Zero switch D5: Stop function	0 0	1 1	0 0	
	Remote parameter	Remote Function Flag: D0: Fahrenheit in display D1: Decimalpoint D2: Show setpoint D3: Display lock at defrost	0 0 0 0	1 1 1 1	0 1 0 0
Remote sensor offset		-10.00	10.00	0.00	
Remote sensor deviation		-10.00	10.00		
Remote sample time		0	100	10	
Remote display lock		0	1440	0	Min

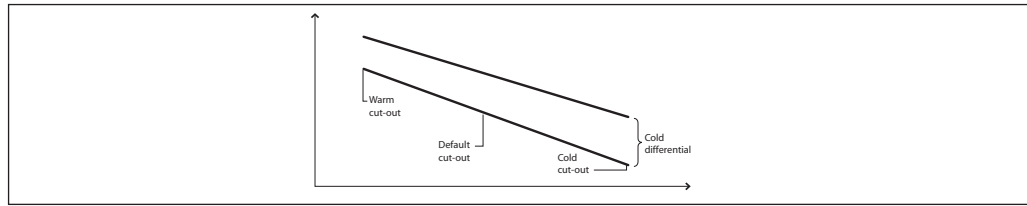

Variants

In order to optimize the efficiency and ensure the reliability of the Danfoss products in your specific applications and systems, always contact Danfoss prior to initiating the use of any Danfoss products.

- You can have the ETC1H with optional 2 or 3 relays, for controlling heaters, fans etc.

- You can have the ETC1H with standard soft-ware or optionally with special customized software for optimized functionality. Please contact Danfoss regarding this..

Danfoss does not accept any responsibility for ETCs placed in environments outside our design specifications. Use of the ETCs in such cases must be verified via relevant field-tests, and always remains the responsibility of the buyer.

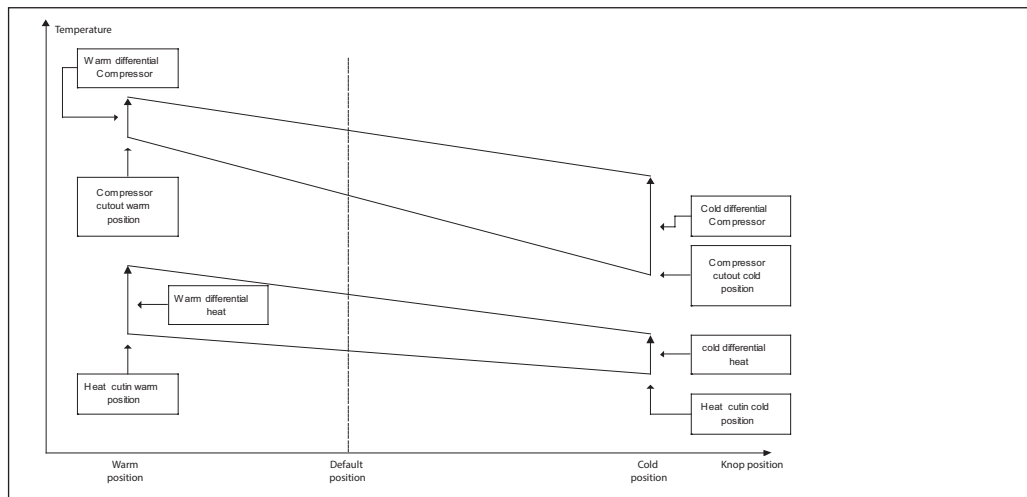

Dual band control of compressor and cabinet heater for outdoor bottle coolers placed in cold environment.

Dimensions and mounting

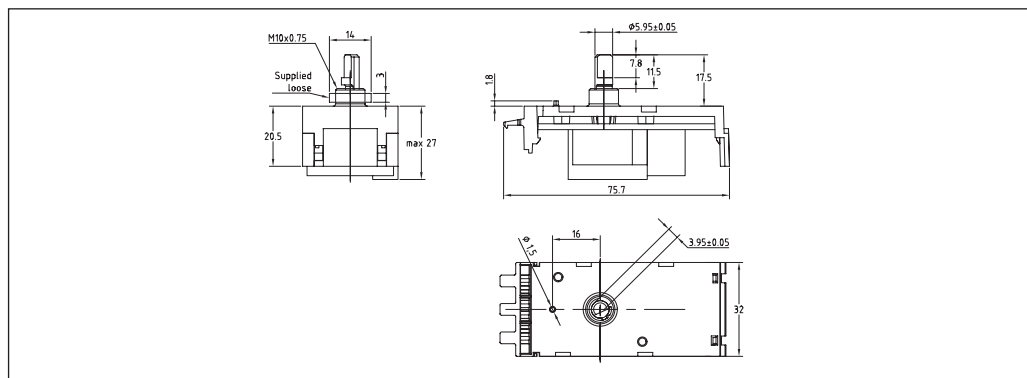

The controls can be mounted using the nut shown or it can be mounted using 2 screws type EJOT DURO-PT dia. 3 × 7 mm.

Warning:

By using screw types different than the above mentioned, there is a risk of short circuiting the line potential.

Please note: All Danfoss knobs have been designed to sit flush against the housing, relieving the load on the spindle arm. Maximum mounting force of knob: 60 Newton. Whenever using non-Danfoss knobs, please ensure that they are mounted as described above and that the maximum mounting force of knob: 60 Newton is not exceeded.