

Data sheet

Electric expansion valves

Types AKVA 10, 15 & 20

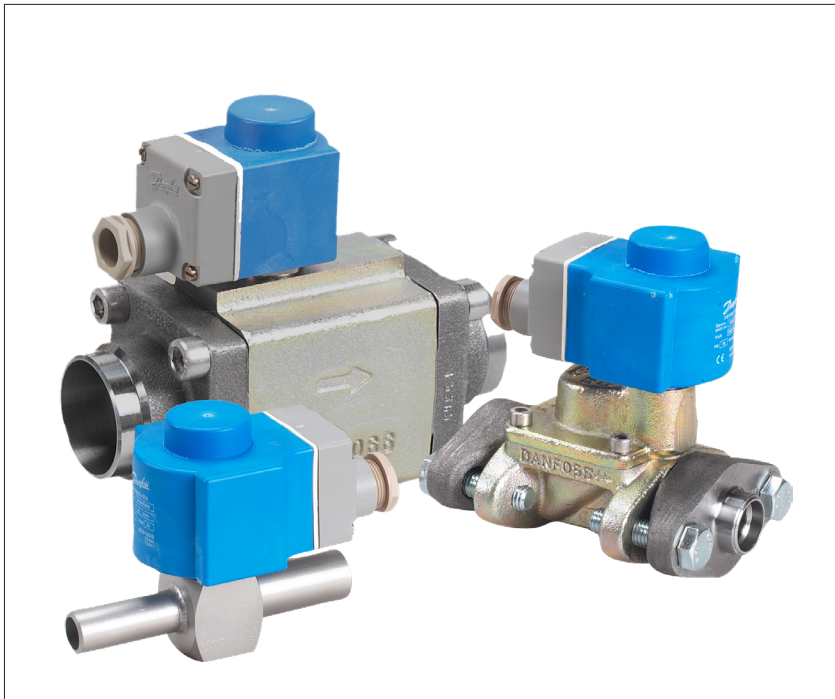

AKVA are electric expansion valves designed for ammonia refrigerating plant.

The AKVA valves are normally controlled by a controller from Danfoss' range of ADAP-KOOL® controllers.

The AKVA valves are supplied as a component programme, as follows:

- Separate valve
- Separate coil with terminal box or cable
- Spare parts in the form upper part, orifice and filter

The individual capacities are indicated with a number forming part of the type designation. The number represents the size of the orifice of the valve in question.

A valve with orifice 3 will for example be designated AKVA 10-3.

The orifice assembly is replaceable.

Features

- For HCFC, HFC, R717 (Ammonia) and R744 (CO₂)
- The valve requires no adjustment
- Wide regulation range
- Replaceable orifice assembly
- Wide range of coils for d.c. and a.c.
- Quick reaction in whole range of stated capacity.
- In some applications AKVA can be used both as expansion valve and solenoid valve.
- Classification: DNV, CRN, BV, EAC etc.
To get an updated list of certification on the products please contact your local Danfoss Sales Company.

Approvals

DEMKO, Denmark
SETI, Finland
SEV, Switzerland

AKVA 20 are CE marked according to Pressure Equipment Directive 97/23



UL listed to U.S. og Canadian standards (separate code. nos.)

Contents	Page
Features	1
Approvals	1
Technical data	3
Rated capacity and ordering	4
Capacity	8
Dimensioning	8
Design	12
Function	13
Dimension and weight	13
Recommandations	14

Data sheet | Electric expansion valves, types AKVA 10, 15 & 20

Technical data

The AKVA 10 valves covers a capacity range from 4 kW to 100 kW (R 717) and are divided up into 8 capacity ranges.

The AKVA 10 valve bodies are made in stainless steel and have weld connections.

The AKVA 15 valves have flange connections. The valve covers a capacity range from 125 kW to 500 kW (R 717) and are divided up into 4 capacity ranges.

The AKVA 20 valves cover a capacity range from 500 kW to 3150 kW (R 717) and are divided up into 5 capacity ranges.

The AKVA 20 valve has weld connections.

The AKVA valves can be used for:

- Flooded evaporation (high/low pressure)
- Pump separators
- Direct expansion. See appendix.

If AKVA has to be used in chillers please contact Danfoss.

The AKVA can be used for HCFC, HFC, R717 (Ammonia) and R744 (CO₂).

Valve type	AKVA 10	AKVA 15	AKVA 20
Tolerance of coil voltage	+10 / -15%	+10 / -15%	+10 / -15%
Enclosure to IEC 529	Max. IP 67	Max. IP 67	Max. IP 67
Working principle (Pulse-width modulation)	PWM	PWM	PWM
Recommend period of time	6 seconds	6 seconds	6 seconds
Capacity (R717)	4 to 100 kW	125 to 500 kW	500 to 3150 kW
Regulation range	10 - 100%	10 - 100%	10 - 100%
Connection	Weld	Weld	Weld
Media temperature	- 50 to 60°C	- 40 to 60°C	- 40 to 60°C
Ambient temperature	- 50 to 50 °C	- 40 to 50 °C	- 40 to 50 °C
Leak of valve seat	< 0.02% of k _v -value	< 0.02% of k _v -value	< 0.02% of k _v -value
MOPD	18 bar	22 bar	18 bar
Filter	Internal 100 µm replaceable	external 100 µm	external 100 µm
Max. working pressure	PS = 42 bar g	PS = 42 bar g	PS = 42 bar g

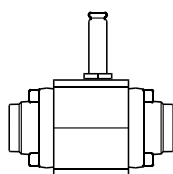
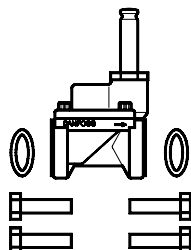
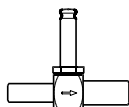
Data sheet | Electric expansion valves, types AKVA 10, 15 & 20
Rated capacity and ordering

Valve type	Rated capacity ¹⁾		k _v -value m ³ /h	Connections Inlet x outlet in.	Code no.	Connections Inlet x outlet in.	Code no.
	kW	tons					
AKVA 10-1	4	1.1	0.010	3/8 x 1/2	068F3261	1/2 x 3/4	068F3281
AKVA 10-2	6.3	1.8	0.015	3/8 x 1/2	068F3262	1/2 x 3/4	068F3282
AKVA 10-3	10	2.8	0.022	3/8 x 1/2	068F3263	1/2 x 3/4	068F3283
AKVA 10-4	16	4.5	0.038	3/8 x 1/2	068F3264	1/2 x 3/4	068F3284
AKVA 10-5	25	7.1	0.055	3/8 x 1/2	068F3265	1/2 x 3/4	068F3285
AKVA 10-6	40	11.4	0.103	3/8 x 1/2	068F3266	1/2 x 3/4	068F3286
AKVA 10-7	63	17.9	0.162			1/2 x 3/4	068F3267
AKVA 10-8	100	28.4	0.251			1/2 x 3/4	068F3268
AKVA 15-1	125	35	0.25	Flange	068F5020²⁾		
AKVA 15-2	200	60	0.40	Flange	068F5023²⁾		
AKVA 15-3	300	90	0.63	Flange	068F5026²⁾		
AKVA 15-4	500	140	1.0	Flange	068F5029²⁾		
AKVA 20-1	500	140	1.0	1 1/4 x 1 1/4	042H2101		
AKVA 20-2	800	240	1.6	1 1/4 x 1 1/4	042H2102		
AKVA 20-3	1250	350	2.5	1 1/4 x 1 1/4	042H2103		
AKVA 20-4	2000	600	4.0	1 1/2 x 1 1/2	042H2104		
AKVA 20-5	3150	900	6.3	2 x 2	042H2105		

¹⁾ Rated capacities are based on
 Condensing temperature t_c = 32°C
 Liquid temperature t_l = 28°C
 Evaporating temperature t_e = 5°C

²⁾ Incl. bolts and gaskets but without flanges

Flange set for AKVA 15

Valve type	Connection (in.)	Code no.
AKVA 15-1 to 4	3/4	027N1220
	1	027N1225

Ordering (continued)
Accessories

Strainer

On plants with ammonia and similar industrial plant a strainer must be mounted in front of AKVA 15 and AKVA 20.

AKVA 10 has built-in strainer and external strainer is not necessary.

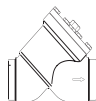

Recommended strainer for AKVA 15 / 20

Strainer type	Code no.	
	House	Strainer insert 100 µm
FIA 20 D STR	148B5343	148H3122
FIA 25 D STR	148B5443	148H3123
FIA 32 D STR	148B5544	
FIA 40 D STR	148B5625	
FIA 50 D STR	148B5713	148H3157

For further information: see Danfoss catalogue DKRCI.PD.FN1.A

Examples of combinations

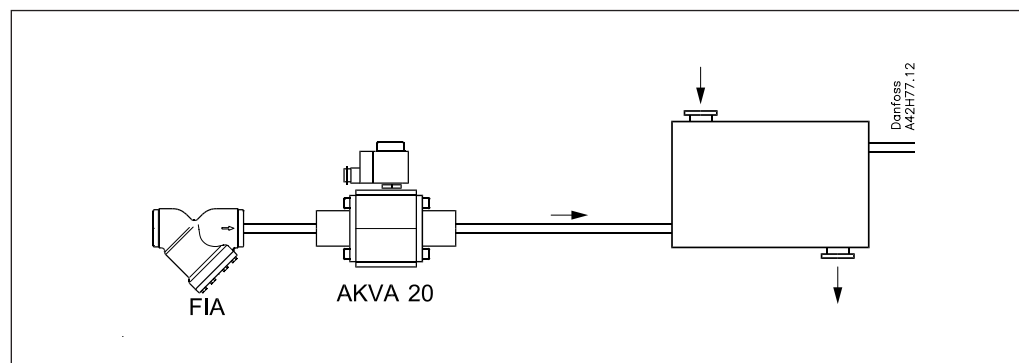

Ordering (continued)
Spare parts
AKVA 10

Orifice

Type	Code no.	Contents
AKVA 10-1	068F0526	1 pcs. orifice 1 pcs. Al. gasket 1 pcs. cap for coil
AKVA 10-2	068F0527	
AKVA 10-3	068F0528	
AKVA 10-4	068F0529	
AKVA 10-5	068F0530	
AKVA 10-6	068F0531	
AKVA 10-7	068F0532	
AKVA 10-8	068F0533	

Filter

	Code no.	Contents
	068F0540	10 pcs. filters 10 pcs. Al. gaskets

Upper part

	Code no.	Contents
	068F5045	1 pcs. armature 1 pcs. armature tube 1 pcs. Al. gasket

AKVA 15

Piston

Type	Code no.	Contents
AKVA 15-1	068F5265	1 pcs. piston assembly 1 pcs. gasket 1 pcs. O-ring 2 pcs. labels
AKVA 15-2	068F5266	
AKVA 15-3	068F5267	
AKVA 15-4	068F5268	

Gasket set	068F5264	Complete gasket set
------------	-----------------	---------------------

Orifice set

	Code no.	Contents
	068F5261	Main orifice Pilot orifice Al gaskets O-rings Gasket

Upper part

	Code no.	Contents
	068F5045	1 pcs. armature 1 pcs. armature tube 1 pcs. Al. gasket

Filter

	Code no.	Contents
	068F0540	10 pcs. filters 10 pcs. Al. gaskets

AKVA 20

Piston

Type	Code no.	Contents
AKVA 20-0.6	042H2039	1 pcs. piston assembly 3 pcs. O-rings
AKVA 20-1	042H2040	
AKVA 20-2	042H2041	
AKVA 20-3	042H2042	
AKVA 20-4	042H2043	
AKVA 20-5	042H2044	

Orifice set

Type	Code no.	Contents
AKVA 20-0.6	068F5270	Main orifice, dia. 8 mm Pilot orifice, dia. 1.8 mm 2 pcs. Al. gaskets O-ring
AKVA 20-1	068F5270	
AKVA 20-2	068F5270	
AKVA 20-3	068F5270	Main orifice, dia. 14 mm Pilot orifice, dia. 2.4 mm 2 pcs. Al. gaskets O-ring
AKVA 20-4	068F5271	
AKVA 20-5	068F5271	

Gasket set	042H0160	Complete gasket set for new and old valves
------------	-----------------	--

Upper part

	Code no.	Contents
	068F5045	1 pcs. armature 1 pcs. armature tube 1 pcs. Al. gasket

Data sheet | Electric expansion valves, types AKVA 10, 15 & 20
Ordering (continued)
Coils for AKVA valves

AKVA 10-1 10-2 10-3 10-4 10-5	AKVA 10-6	AKVA 10-7 10-8	AKVA 15-1 15-2 15-3 15-4	AKVA 20-1 20-2 20-3	AKVA 20-4 20-5
--	--------------	----------------------	--------------------------------------	------------------------------	----------------------

D.C. coils	Code no.						
220 V d.c. 20 W, standard with terminal box	018F6851	+	+	+	+	+	+
100 V d.c. 18 W, special with terminal box with DIN plugs	018F6780	+	+	+	+	+	+
230 V d.c. 18 W, special with terminal box with DIN plugs	018F6781¹⁾ 018F6991¹⁾	+	+	+	+	+	+
230 V d.c. 18 W, special with 2.5 m cable with 4.0 m cable with 8.0 m cable	018F6288¹⁾ 018F6278¹⁾ 018F6279¹⁾	+	+	+	+	+	+

¹⁾ Recommended for commercial refrigeration plant

A.C. coils	Code no.						
240 V a.c. 10 W, 50 Hz with terminal box with DIN plugs	018F6702 018F6177	+	+	-	+	-	-
240 V a.c. 10 W, 60 Hz with terminal box with DIN plugs	018F6713	+	+	-	+	-	-
240 V a.c. 12 W, 50 Hz with terminal box	018F6802	+	+	+	+	+	-
220 V a.c. 10 W, 50 Hz with terminal box with DIN plugs	018F6701 018F6176	+	+	-	+	-	-
220 V a.c. 10 W, 60 Hz with terminal box with DIN plugs	018F6714 018F6189	+	+	-	+	-	-
220 V a.c. 12 W, 50 Hz with terminal box	018F6801	+	+	-	+	+	-
220 V a.c. 12 W, 60 Hz with terminal box	018F6814	+	+	-	+	+	-
115 V a.c. 10 W, 50 Hz with terminal box with DIN plugs	018F6711 018F6186	+	+	-	+	-	-
115 V a.c. 10 W, 60 Hz with terminal box with DIN plugs	018F6710 018F6185	+	+	-	+	-	-
110 V a.c. 12 W, 50 Hz with terminal box	018F6811	+	+	-	+	+	-
110 V a.c. 12 W, 60 Hz with terminal box	018F6813	+	+	-	+	+	-
24 V a.c. 10 W, 50 Hz with terminal box with DIN plugs	018F6707 018F6182	+	-	-	+	-	-
24 V a.c. 10 W, 60 Hz with terminal box with DIN plugs	018F6715	+	-	-	+	-	-
24 V a.c. 12 W, 50 Hz with terminal box	018F6807	+	-	-	+	+	+
24 V a.c. 12 W, 60 Hz with terminal box	018F6815	+	-	-	+	+	+
24 V a.c. 20 W, 50 Hz with terminal box	018F6901	+	+	+	+	+	+
24 V a.c. 20 W, 60 Hz with terminal box	018F6902	+	+	+	+	+	+

Capacity

Range: -40 to 10°C

R 717

Valve type	Capacity in kW at pressure drop across valve Δp bar							
	2	4	6	8	10	12	14	16
AKVA 10 - 1	2.2	3.1	3.7	4.1	4.4	4.7	5.0	5.2
AKVA 10 - 2	3.5	4.9	5.8	6.5	7.0	7.5	7.9	8.3
AKVA 10 - 3	5.6	7.7	9.1	10.2	11.1	11.9	12.5	13.1
AKVA 10 - 4	9.1	12.4	14.7	16.5	17.9	19.2	20.2	21.1
AKVA 10 - 5	14.2	19.4	22.9	25.7	28.0	29.9	31.6	33.0
AKVA 10 - 6	23.0	31.2	36.4	41.4	45.0	48.1	50.7	53.1
AKVA 10 - 7	36.6	49.3	58.1	65.0	70.6	75.3	79.4	83.0
AKVA 10 - 8	59.1	78.9	93.5	104	112	120	126	131
AKVA 15 - 1		95.7	113	127	138	148	156	163
AKVA 15 - 2		153	181	203	221	236	250	261
AKVA 15 - 3		231	274	308	335	358	377	395
AKVA 15 - 4		383	455	510	555	593	625	655
AKVA 20 - 1		383	455	510	555	593	625	655
AKVA 20 - 2		612	726	814	886	947	999	1045
AKVA 20 - 3		959	1137	1275	1388	1482	1564	1635
AKVA 20 - 4		1552	1836	2057	2239	2391	2523	2639
AKVA 20 - 5		2479	2921	3267	3550	3789	3994	4174

Correction for subcooling

The liquid injected capacity must be corrected, if the subcooling deviates from 4 K. Use the actual correction factor indicated in the table.

Multiply the liquid injected capacity by the correction factor to obtain the corrected capacity.

Correction factors for subcooling Δt_{sub}

Correction factor	2K	4 K	10 K	15 K	20 K	25 K	30 K	35 K	40 K	45 K	50 K
R 717	1.01	1.00	0.98	0.96	0.94	0.92	0.91	0.89	0.87	0.86	0.85

Corrected capacity = liquid injected capacity x correction factor.

Dimensioning

To obtain an expansion valve that will function correctly under different load conditions it is necessary to consider the following points when the valve has to be dimensioned: These points must be dealt with in the following sequence:

1. Evaporator capacity
2. Pressure drop across the valve
3. Correction for subcooling
4. Correction for evaporating temperature
5. Determination of valve size
6. Correctly dimensioned liquid line

Dimensioning
(continued)

Example for a direct expansion system

1. Evaporator capacity

The evaporator capacity is found in the specifications from the evaporator supplier.

2. Pressure drop across the valve

The pressure drop across the valve directly determines the capacity and must therefore be considered.

The pressure drop across the valve is normally calculated as the condensing pressure less the

evaporating pressure and sundry other pressure drops in the liquid line, distributor, evaporator, etc.

It is indicated in the following formula:

$$\Delta p_{\text{valve}} = p_c - (p_e + \Delta p_1 + \Delta p_3 + \Delta p_4)$$

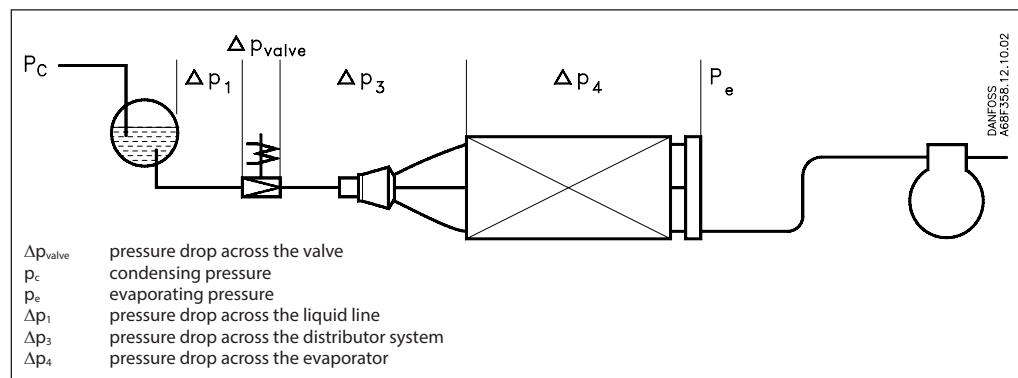

Note!

The pressure drop across the liquid line and the distributor system must be calculated on the basis of the valve's max. capacity, as the valve operates with pulse-width modulation.

This will give you the following equation:

$$\begin{aligned} \Delta p_{\text{valve}} &= p_c - (p_e + \Delta p_1 + \Delta p_3 + \Delta p_4) \\ &= 13.5 - (1.9 + 0.2 + 0.8 + 0.1) \\ &= 10.5 \text{ bar} \end{aligned}$$

Example of calculation of pressure drop across a valve:

Refrigerant: R 717

Condensing temperature: 35°C ($p_c = 13.5$ bar)

Evaporating temperature: -20°C ($p_e = 1.9$ bar)

$\Delta p_1 = 0.2$ bar

$\Delta p_3 = 0.8$ bar

$\Delta p_4 = 0.1$ bar

The found value for "pressure drop across the valve" is used later in the section "Determination of valve size".

3. Correction for subcooling

The evaporator capacity used must be corrected, if the subcooling deviates from 4 K.

Use the actual correction factor indicated in the table.

Multiply the evaporator capacity by the correction factor to obtain the corrected capacity.

Correction factors for subcooling Δt_{sub}

Correction factor	2K	4 K	10 K	15 K	20 K	25 K	30 K	35 K	40 K	45 K	50 K
R 717	1.01	1.00	0.98	0.96	0.94	0.92	0.91	0.89	0.87	0.86	0.85

Corrected capacity = evaporator capacity x correction factor.

The corrected capacity is used in the section "Determination of valve size".

Note:

Too little subcooling may cause flash gas.

Example of correction:

Refrigerant: R 717

Evaporator capacity Q_e : 300 kW

Subcooling: 10 K

Correction factor according to the table = 0.98

Corrected evaporator capacity = 300 x 0.98 = 294 kW.

Dimensioning
(continued)

4. Correction for evaporating temperature (t_e)

To obtain a correctly dimensioned valve it is important that the application is considered.

Depending on the application, the valve should have an overcapacity enabling it to cope with the extra amount of refrigeration needed during certain periods, e.g. during the defrost recovery process.

The valve's opening degree should therefore be between 50 and 75% when regulating. In this way

it is ensured that the valve has a sufficiently wide regulation range, so that it can manage changed loads at or near the normal working point.

Correction factors based on the evaporating temperature are indicated below:

Correction factors for evaporating temperature (t_e)

Evaporating temperature t_e , °C	5	0	- 10	- 15	- 20	- 30	- 40
AKVA 10, AKVA 15, AKVA 20	1.0	1.0	1.0	1.0	1.2	1.3	1.4

5. Determination of valve size

When the valve size meeting the required capacity is selected it is important to note that the capacity indications are the valve's rated capacity, i.e. when the valve is 100% open.

In this section we tell you how the valve's size is determined.

There are three factors that have an influence on the choice of the valve:

- the pressure drop across the valve
- the corrected capacity (correction for subcooling)
- the corrected capacity for evaporating temperature

The three factors have been described earlier in this section on dimensioning. When these three factors have been established, the selection of the valve can be made:

- First you multiply the "corrected capacity" by a value stated in the table.
- Use the new value in the capacity table in combination with the pressure drop value.
- Now select the valve size.

Example of selection of valve

Use as starting point the two earlier mentioned examples, where the following two values have been obtained:

$$\Delta p_{\text{valve}} = 10.5 \text{ bar}$$

$$Q_{e \text{ corrected}} = 294 \text{ kW}$$

From tabel "Correction factors for evaporating temperature", factor 1.2 is given for the evaporating temperature -20°C.

The dimensioned capacity will then be:

$$1.2 \times 294 \text{ kW} = 353 \text{ kW.}$$

Now select a valve size from tabel "Capacity".

With the given values $\Delta p_{\text{valve}} = 10.5 \text{ bar}$ and a capacity of 353 kW, AKVA 15 - 4 is selected.

This valve will have a capacity of approx. 555 kW.

6. Correctly dimensioned liquid line

To obtain a correct supply of liquid to the AKVA valve, the liquid line to the individual AKVA valve must be correctly dimensioned.

The liquid flow rate must not exceed 1 m/sec at a fully open valve.

This must be observed on account of the pressure drop in the liquid line (lack of subcooling) and pulsations in the liquid line.

Dimensioning of the liquid line must be based on the capacity of the valve at the pressure drop with which it is operating (cf. capacity table), and not on the evaporator's capacity, see next page

Dimensioning
(continued)

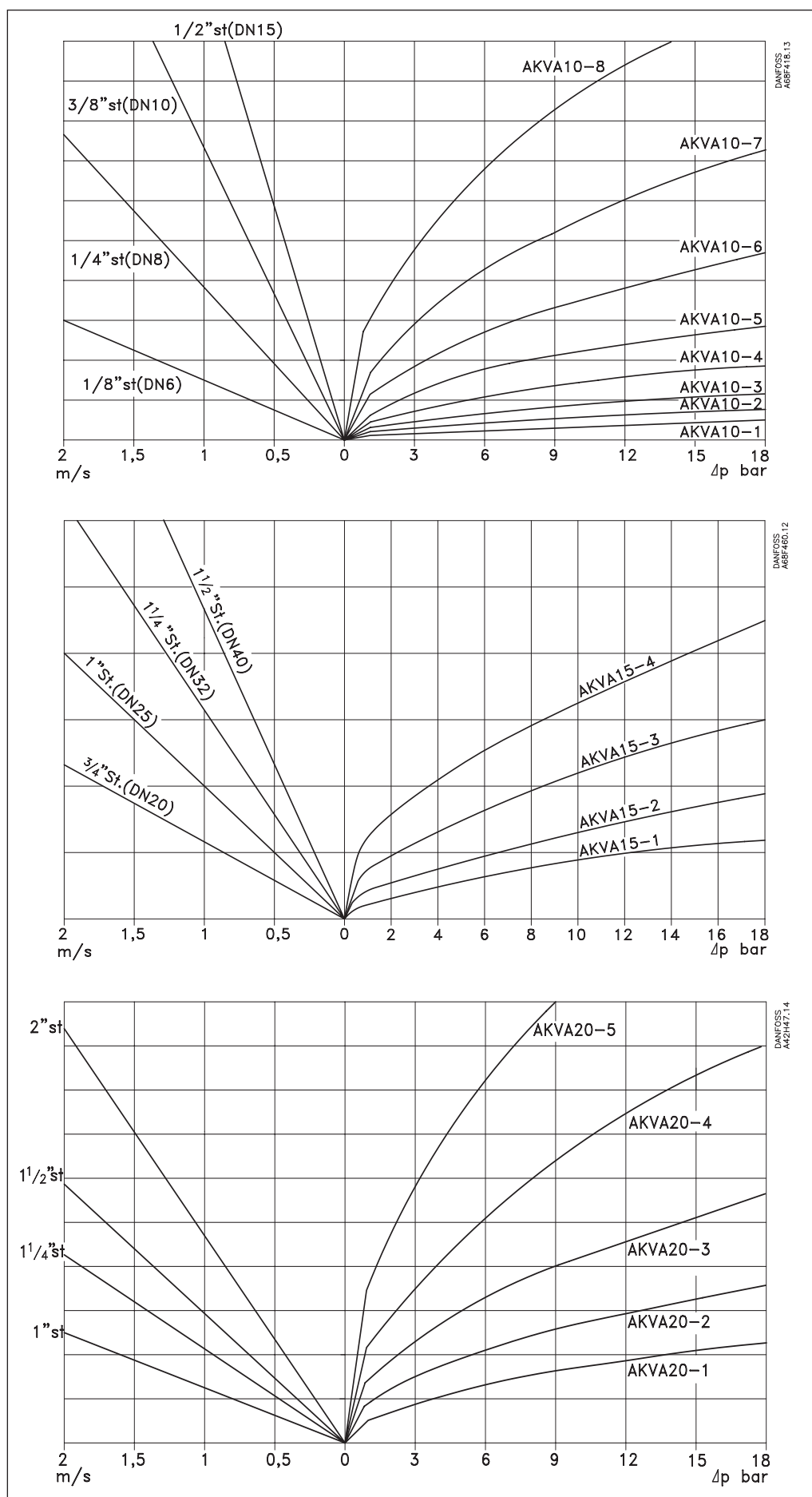

Design

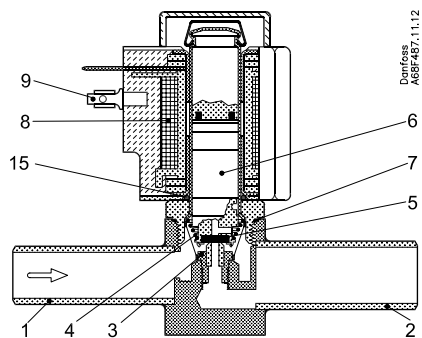

Danfoss
A6BF467.11.12

AKVA 10

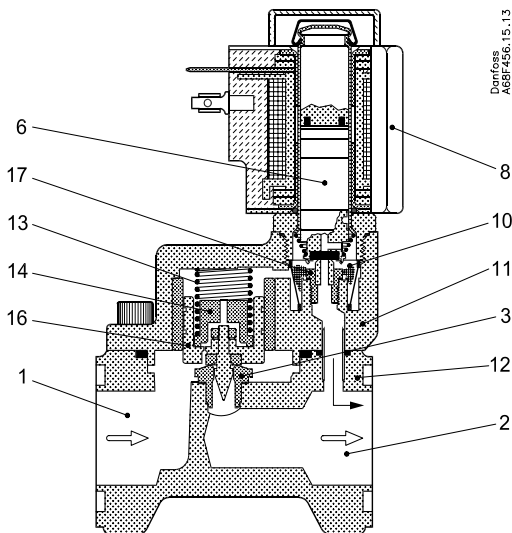

Danfoss
A6BF456.15.13

1. Inlet
2. Outlet
3. Orifice
4. Filter
5. Valve seat
6. Armature
7. Aluminium gasket
8. Coil
9. DIN plug
10. Filter
11. Cover
12. Valve body
13. Spring
14. Orifice assembly
15. O-ring
16. Piston assembly
17. Pilot orifice
18. Pilot valve

AKVA 15

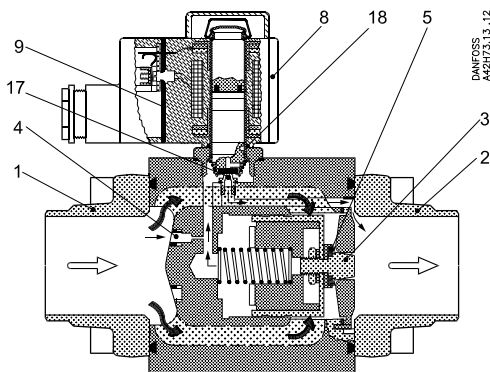

DANFOSS
A42H73.13.12

AKVA 20

Function

The valve capacity is regulated by means of pulse-width modulation. Within a period of six seconds a voltage signal from the controller will be transmitted to and removed from the valve coil. This makes the valve open and close for the flow of refrigerant.

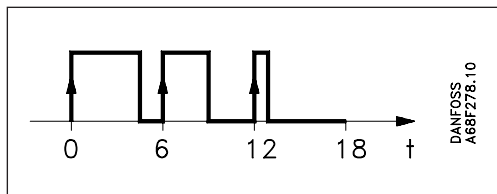

The relation between this opening and closing time indicates the actual capacity. If there is an intense need for refrigeration, the valve will remain open for almost all six seconds of the period. If the required amount of refrigeration is modest, the valve will only stay open during a fraction of the period. The amount of refrigeration needed is determined by the controller.

When no refrigeration is required, the valve will remain closed.

In some applications, AKVA can advantage-ously be used both as expansion valve and solenoid valve. See appendix.

Dimension and weight

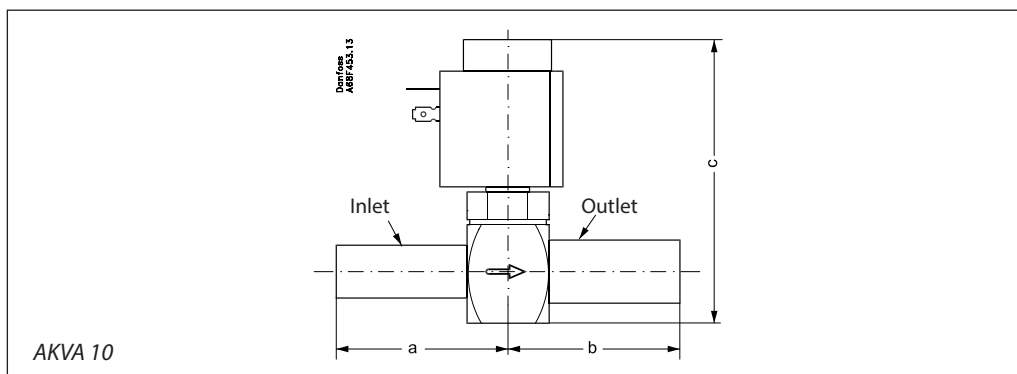

Valve type		A mm	B mm	C mm	Connection		Weight without coil kg
					Inlet in.	Outlet in.	
AKVA 10	1 → 6	60	60	113	3/8	1/2	0.35
AKVA 10	7 → 8	60	60	113	1/2	3/4	0.35

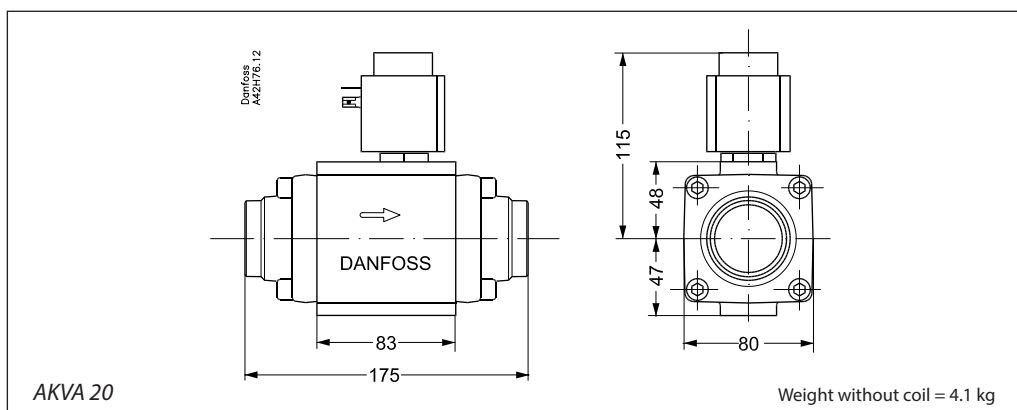
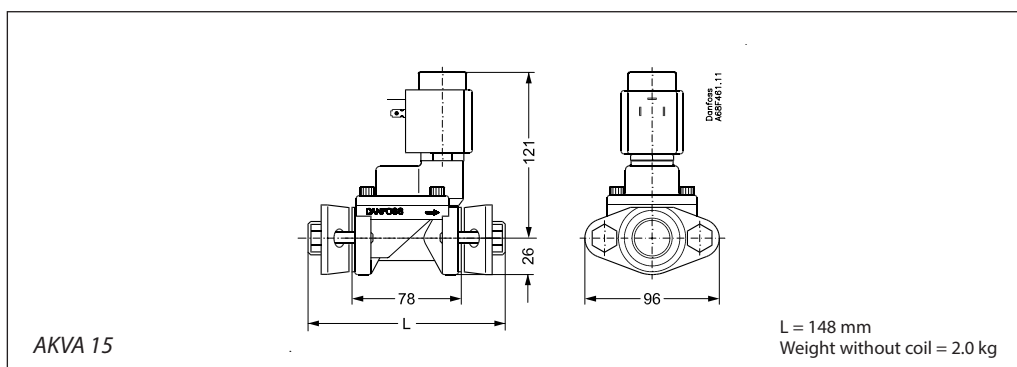

Appendix

Recommendations

It is important to realize when AKVA is operating, that the valve always is fully open or fully closed.

That means that this way of operation should always be considered during the refrigeration design. (Piping, liquid velocity, sub cooling etc.)

Danfoss have the following recommendations/guidelines to be taken into considerations.

- In 1:1 applications (1 evaporator, 1 condenser and 1 compressor) chillers with a small amount of refrigerant or installed in front of a Plate Heat Exchangers, it must be observed that every time the AKVA is fully open or closed it will have a significant impact on the hole system. (e.g. pressure variations on suction side).

Please observe that the performance of such a system is not only related to one component. (e.g. AKVA) Other factors which is very important to include in the overall refrigeration system design:

- Liquid distribution at and design of evaporator
- total evaporator coil is of adequate length thus superheat can be controlled within the entered period time (normal 6 sec. or 3 sec.)
- mounting principle of temperature sensor, to ensure a steady and fast signal can be detected by the electronic system.

- If pressure dependent valves like, PM with pilots like CVP e.t.c., is installed between evaporator and compressor, it can effect the lifetime of PM, because the piston of the PM will operate together with operation of AKVA. Type of refrigerant and evaporator has a big influence of the size of pulsations after the evaporator and in front of the PM.
- AKVA is a direct pressure independent valve unlike TQ, PHTQ and TEAQ, which all are pressure dependent. That means that if non-Danfoss electronic controllers is used, intelligent and fast optimal control is needed, because the quick pressure changes only can be detected and compensated via the electronic control system.
- Liquid lines must be designed according to AKVA capacity and not evaporator capacity.
- To avoid flash-gas ensure sufficient sub-cooling or design liquid lines thus to big pressure drop is avoided, when AKVA is open. If not sufficient subcooling is not obtained (normally 4K) it will have an impact on the lifetime of the valve.
- Where the demand for safety level is extremely high, (e.g. Liquid Level Control in a pump separator) an extra valve can be installed in front of AKVA to avoid leakage. This valve must be Danfoss type EVRAT.
- Always install a 100 µm filter in front of AKVA 15 and AKVA 20 valves.
- If AKVA has to be used in chillers. Please contact Danfoss.