

Data sheet

Float valves

Types SV 1 and SV 3



The SV 1 and 3 can be used separately as a modulating liquid level regulator in refrigerating, freezing and air conditioning systems for ammonia or fluorinated refrigerants.

However, in most cases, the SV is used as a float pilot valve for the main expansion valve type PMFH.

Technical data

- *Refrigerant*
Applicable to HCFC, HFC and R717 (Ammonia).
- *P band*
35 mm
- *Temperature of medium*
-50 to +65°C
- *Max. working pressure*
PS = 28 bar
- *Max. test pressure*
p' = 36 bar
- *k_v value for float orifice*
SV 1 = 0.06 m³/h
SV 3 = 0.14 m³/h
- The highest k_v value for the built-in throttle valve is 0.18 m³/h. The throttle valve can be used both in parallel and in series with the float orifice.
- Classification: DNV, CRN, BV, EAC etc.
To get an updated list of certification on the products please contact your local Danfoss Sales Company.

Approvals



Pressure Equipment Directive (PED)
SV1 and 3 are approved in accordance with the European standard specified in the Pressure Equipment Directive and are CE marked.

For further details / restrictions - see Installation Instruction

	SV1 and 3
Classified for	Fluid group I
Category	I

Identification

Dimensioning example for SV (L)

Refrigerant
R717 (NH₃)

Evaporating capacity
Q_e = 27 kW

Evaporating temperature
t_e = -10°C (~ p_e = 2.9 bar abs.)

Condensing temperature
t_c = +30°C (~ p_c = 11.7 bar abs.)

Liquid temperature for SV
t_l = +20°C

Subcooling
Δt_{sub} = t_c - t_l = 30°C - 20°C = 10 K

Pressure drop in SV
Δp = p_c - p_e = 11.7 - 2.9 = 8.8 bar

Correction factor k for 10 K subcooling
0.98

Corrected capacity
27 × 0.98 = 26.4 kW

At t_e = -10°C and Δp = 8 bar SV 1 yields 27 kW and can therefore be used.

If SV 3 is used for this capacity, it will mean a small offset.

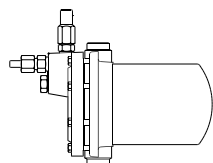
Ordering

Regulator

The code nos. stated apply to float valves, types SV 1 and SV 3 incl. Ø 6.5 / Ø 10 mm weld connection ¹⁾ for the pilot line. Balance tube connection (liquid/vapour): 1 in. weld / 1 1/8 in. solder.

The rated capacity refers to the valve capacity at evaporating temperature t_e = +5°C, condensing temp. t_c = +32°C and liquid temperature t_l = +28°C.

Valve type	Code no.	Rated capacity in kW					
		R717	R22	R134a	R404A	R12	R502
SV 1	027B2021	25	4.7	3.9	3.7	3.1	3.4
SV 3	027B2023	64	13	10.0	9.7	7.9	8.8

¹⁾ 3/8 in. flare connection can be supplied under code no. **027B2033**.

Spare parts and accessories
See spare parts catalogue.

Pipe dimensions
Liquid line

The following suggested dimensions for the liquid line, which is connected to the nipple pos. C, see "Design / Function", are based on a maximum velocity in a line with subcooled

ammonia of approx. 1 m/s and a maximum velocity in a line with subcooled fluorinated refrigerant of approx. 0.5 m/s.

1. R717 (ammonia)

Type	Dimensions	
	0.8 bar < Δp _{sv} < 4 bar	4 bar < Δp _{sv} < 16 bar
	Steel tube	Steel tube
SV 1	3/8 in.	3/8 in.
SV 3	3/8 in.	1/2 in.

2. R22, R134a, R404A

Type	Dimensions			
	0.8 bar < Δp _{sv} < 4 bar		4 bar < Δp _{sv} < 16 bar	
	Steel tube	Copper tube	Steel tube	Copper tube
SV 1	3/8 in.	3/8 in.	3/8 in.	1/2 in.
SV 3	3/8 in.	3/8 in.	1/2 in.	3/4 in.

Upper balance pipe (connect to pos. D on SV (L))

Type	Dimensions
SV (L) 1	1 in.
SV (L) 3	1 1/2 in.

Data sheet | Float valves, types SV 1 and 3

Capacity

The values in the capacity tables are based on a subcooling of 4 K just ahead of the SV valve.

If the subcooling is more or less than 4 K, refer to the following correction factors.

Type	Evaporating temperature t_e °C	Capacity in kW at pressure drop across valve Δp bar							
		0.8	1.2	1.6	2	4	8	12	16

Type	Evaporating temperature t_e °C	Capacity in kW at pressure drop across valve Δp bar							
		0.8	1.2	1.6	2	4	8	12	16

R717 (NH₃)

Type	Evaporating temperature t_e °C	Capacity in kW at pressure drop across valve Δp bar							
		0.8	1.2	1.6	2	4	8	12	16
SV 1	+10	9.5	11	13	15	20	27	30	33
	0	9.9	12	14	15	20	27	31	33
	-10	10	12	14	15	21	27	31	33
	-20	11	12	14	15	21	27	30	33
	-30	11	12	14	15	20	26	30	33
	-40	11	13	14	15	20	26	29	32
SV 3	+10	25	31	35	39	52	71	77	83
	0	26	32	36	40	52	69	78	83
	-10	26	32	36	40	52	68	77	83
	-20	26	31	35	39	52	67	76	82
	-30	25	30	34	38	50	66	75	82
	-40	24	29	33	36	49	65	73	80
-50	23	27	31	35	47	64	71	79	

R22

Type	Evaporating temperature t_e °C	Capacity in kW at pressure drop across valve Δp bar							
		0.8	1.2	1.6	2	4	8	12	16
SV 1	+10	2.2	2.6	3.0	3.2	4.2	4.8	5.7	5.7
	0	2.3	2.7	3.1	3.4	4.4	4.9	5.8	5.8
	-10	2.4	2.8	3.2	3.5	4.5	5.0	5.8	5.9
	-20	2.4	2.9	3.3	3.6	4.6	5.0	5.8	5.8
	-30	2.5	2.9	3.3	3.6	4.5	5.0	5.7	5.7
	-40	2.5	2.9	3.3	3.6	4.4	4.9	5.6	5.6
SV 3	+10	5.6	6.8	7.7	8.5	11	13	15	15
	0	5.8	7.0	8.0	8.8	11	13	15	15
	-10	6.0	7.3	8.2	9.0	12	13	15	15
	-20	6.1	7.3	8.3	8.9	11	13	14	15
	-30	6.2	7.3	8.1	8.8	11	12	14	14
	-40	6.1	7.1	7.9	8.5	11	12	14	14
-50	5.9	6.9	7.6	8.2	11	12	13	14	

Correction factors

When dimensioning, multiply the evaporator capacity by a correction factor k dependent on the subcooling Δt_{sub} just ahead of the valve. The corrected capacity can then be found in the capacity table.

R717 (NH₃)

Δt K	2	4	10	15	20	25	30	35	40	45	50
k	1.01	1.00	0.98	0.96	0.94	0.92	0.91	0.89	0.87	0.86	0.85

R22

Δt K	2	4	10	15	20	25	30	35	40	45	50
k	1.01	1.00	0.96	0.93	0.90	0.87	0.85	0.83	0.80	0.78	0.77

**Design
Function**

SV with low-pressure function

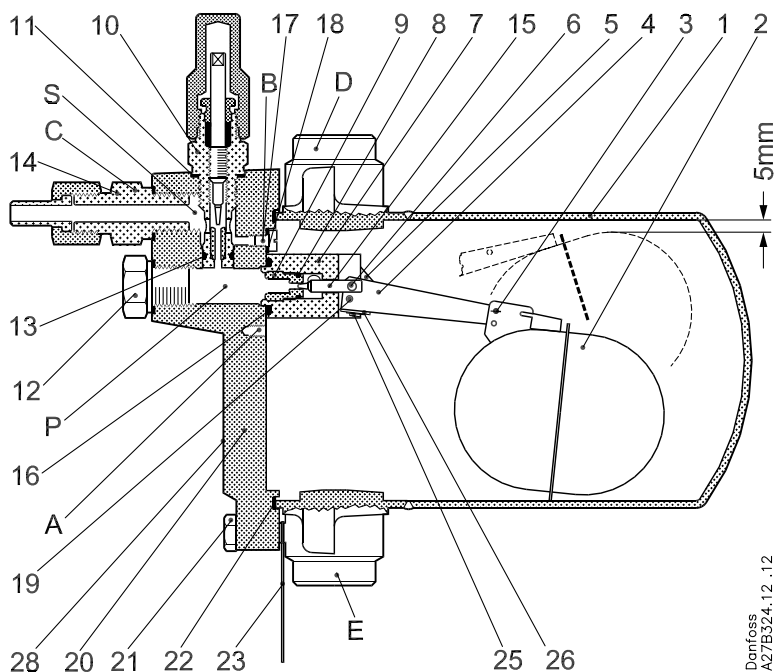

- C. Nipple
- D. Connection for balance pipe
- P. Parallel connection of pos. C (screw 17 in pos. A)
- S. Series connection of pos. C (screw 17 in pos. B)

Danfoss
A27B324.12.12

No.	Part	Material	DIN / EN
1	Float housing	Stainless steel Low temperature, steel	X5CrNi18-10, DIN 17440 P285QH, EN 10222-4
2	Float	Stainless steel	
3	Split pin	Steel	
4	Float arm	Stainless steel	
5	Link	Steel	
6	Pin	Stainless steel	
7	Valve housing	Steel	
8	O-ring	Cloroprene (Neoprene)	
9	Float orifice	Plastic	
10	Manual regulation unit. Throttle valve	Steel	
11	Gasket	Non asbestos	
12	Plug	Steel	
13	O-ring	Cloroprene (Neoprene)	
14	Pilot connection (spare part)	Steel	
15	Orifice needle	Plastic	
16	O-ring	Cloroprene (Neoprene)	
17	Screw	Steel	
18	Gasket	Non asbestos	
19	Pin	Steel	
20	Cover	Low temperature, cast iron (spherical)	EN-GJS-400-18-LT EN 1563
21	Screw	Stainless steel	A2-70
22	Gasket	Non asbestos	
23	Label	Cardboard	
25	Screw	Steel	
26	Spring washer	Steel	
28	Sign	Aluminium	

**Design
Function**
(continued)

SV (L), low-pressure function
SV (L) is used for small, flooded evaporators, where only slight variations in the liquid level can be accepted.

When the liquid level falls, the float pos. (2) moves downwards. This draws the needle pos. (15) away from the orifice and the amount of liquid injected is increased.

The liquid inlet line, which is mounted on the nipple pos. (C), should be dimensioned in such a way *that acceptable liquid velocities and pressure drops are obtained.*

This is particularly important when the liquid is only slightly subcooled, since valve capacity is reduced considerably if flashgas occurs in the liquid ahead of the orifice and wear is strongly increased.

See the suggested dimensions for the liquid line in "Pipe dimensions".

The flashgas quantity which occurs on expansion is removed through the balance pipe from pos. (D). On refrigeration plant using fluorinated refrigerants, slight subcooling and a large pressure drop can give a flashgas quantity of approx. 50% of the injected liquid quantity.

Therefore the pressure drop in this balance pipe must be kept at a minimum, since there will otherwise be a risk that

the liquid level in the evaporator will vary to an unacceptable degree as a function of evaporator load

the absolute difference between the liquid level of the evaporator and the SV valve will be too large.

See the suggested dimensions for the balance pipe in "Pipe dimensions".

Design Function
(continued)

SV with high-pressure function

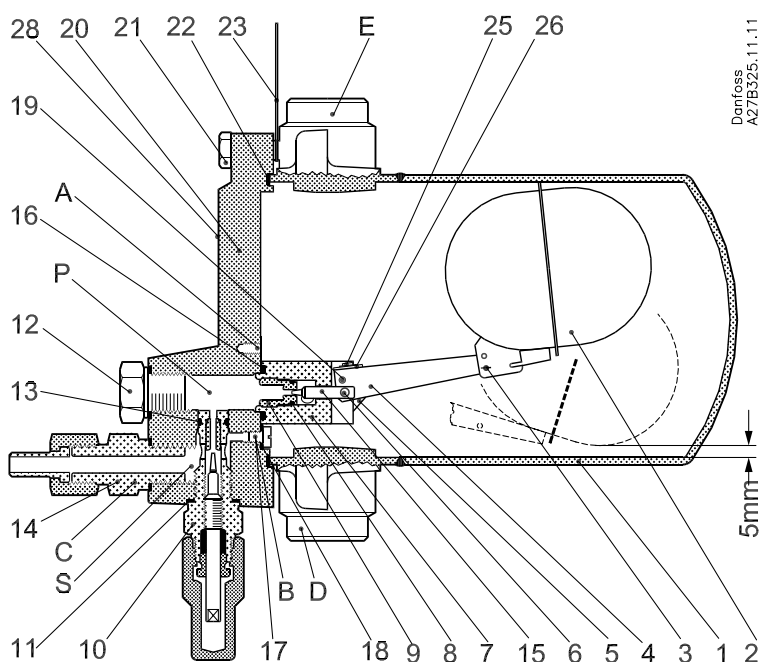

- C. Nipple
- D. Connection for balance pipe
- P. Parallel connection of pos. C (screw 17 in pos. A)
- S. Series connection of pos. C (screw 17 in pos. B)

No.	Part	Material	DIN / EN
1	Float housing	Stainless steel Low temperature, steel	X5CrNi18-10, DIN 17440 P285QH, EN 10222-4
2	Float	Stainless steel	
3	Split pin	Steel	
4	Float arm	Stainless steel	
5	Link	Steel	
6	Pin	Stainless steel	
7	Valve housing	Steel	
8	O-ring	Cloroprene (Neoprene)	
9	Float orifice	Plastic	
10	Manual regulation unit. Throttle valve	Steel	
11	Gasket	Non asbestos	
12	Plug	Steel	
13	O-ring	Cloroprene (Neoprene)	
14	Pilot connection (spare part)	Steel	
15	Orifice needle	Plastic	
16	O-ring	Cloroprene (Neoprene)	
17	Screw	Steel	
18	Gasket	Non asbestos	
19	Pin	Steel	
20	Cover	Low temperature, cast iron (spherical)	EN-GJS-400-18-LT EN 1563
21	Screw	Stainless steel	A2-70
22	Gasket	Non asbestos	
23	Label	cardboard	
25	Screw	Steel	
26	Spring washer	Steel	
28	Sign	Aluminium	

Design Function
(continued)

SV (H), high-pressure function
SV (H) is used as a liquid level regulator for small condensers or receivers.
When the liquid level rises, the float pos. (2) moves upwards. This draws the needle pos. (15) away from the orifice and the excess liquid is drawn away.
On refrigeration plant using fluorinated refrigerants slight subcooling and a large pressure drop can, as already mentioned, cause the formation of a large amount of flashgas.

This mixture of liquid and vapour has to pass through the nipple pos. (C) and out into the liquidline.
If the dimensions of the line are too small, a pressure drop will occur which can reduce the capacity of the SV (H) valve considerably. This will mean a risk of inadvertent liquid accumulation in the condenser or receiver.
See the suggested dimensions for the liquid line in "Pipe dimensions".

The connection nipple (C) can be mounted either in P or in S.

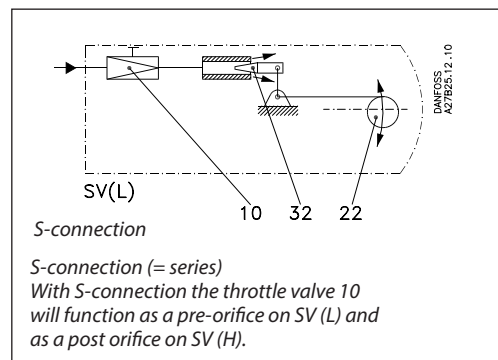
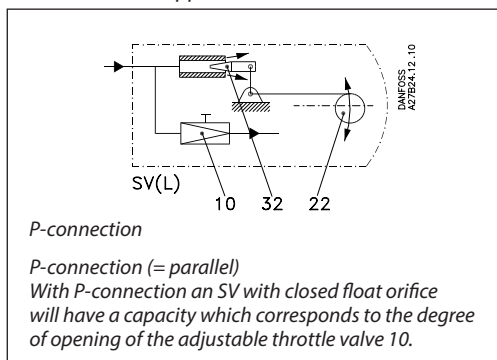

SV 1 - 3 used as a high pressure defrost drain float valve

SV 1 - 3 can be used as a defrost drain float valve, when one balance pipe is sealed off and the liquid level regulator is mounted with a special kit (code no. 027B2054) consisting of:

- Special orifice and orifice needle with a larger k_v -value of 0.28 m³/h.
- Gas drain pipe

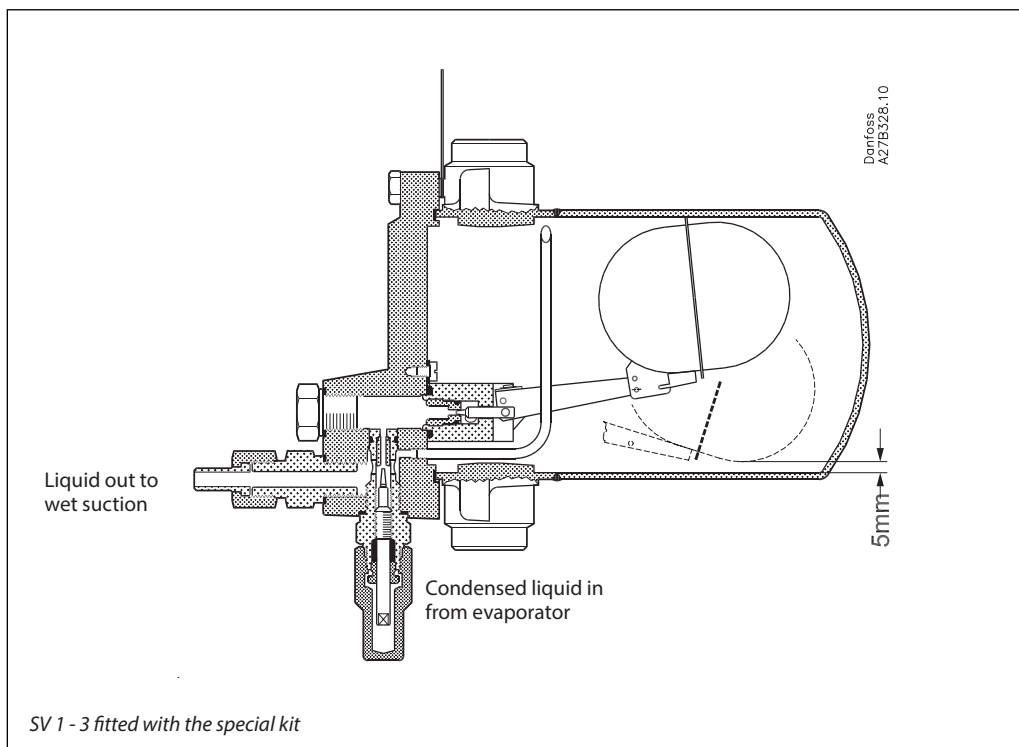

SV 1 - 3 used as a high pressure defrost drain float valve (continued)

Application example

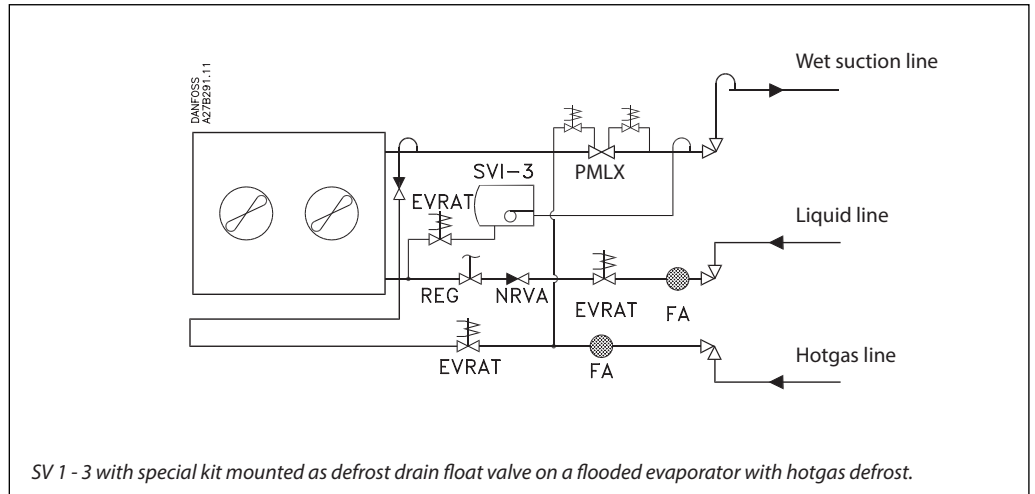

Dimensions and weight

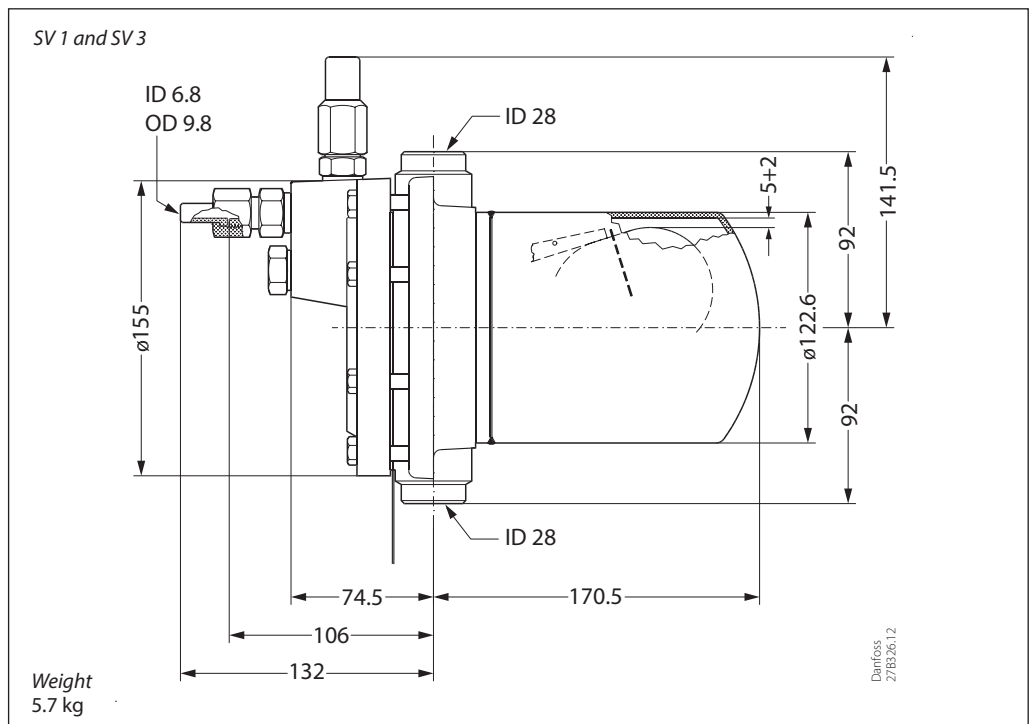

Pilot connection (weld / solder)

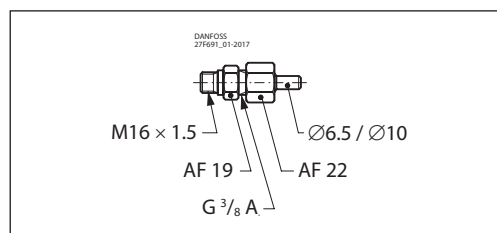

Danfoss can accept no responsibility for possible errors in catalogues, brochures and other printed material. Danfoss reserves the right to alter its products without notice. This also applies to products already on order provided that such alterations can be made without consequential changes being necessary in specifications already agreed. All trademarks in this material are property of the respective companies. Danfoss and the Danfoss logotype are trademarks of Danfoss A/S. All rights reserved.