

Data sheet

CI-tronic™ Soft starters for Danfoss commercial compressor applications

Type MCI 15C, MCI 25C, MCI 50CM-3 I-O



The MCI compressor soft starters are designed for soft starting of 3 phase compressors. During start the MCI will gradually increase the voltage to the motor until it reaches full line voltage.

The soft start ramp-up time and initial start torque is preset to ensure a fast start and allow easy and quick installation.

MCI compressor soft starters are ideal for use on Danfoss Performer scroll and Maneurop Reciprocating compressors. The starting current can be reduced by up to 40% of the direct on line value.

Features

- Universal control voltage: 24 – 480 V AC/DC
- Automatic detection of missing phases
- LED Status indication.
- Automatic adaptation to 50/60 Hz
- Easy and quick installation
- Up to 12 start/stop operations per hour
- Built in varistor protection
- IP20 Protection
- Compact modular design
- DIN rail mountable
- Ramp-time max. 0.5 s (factory set-up)
- EN 60947-4-2

Functional diagram

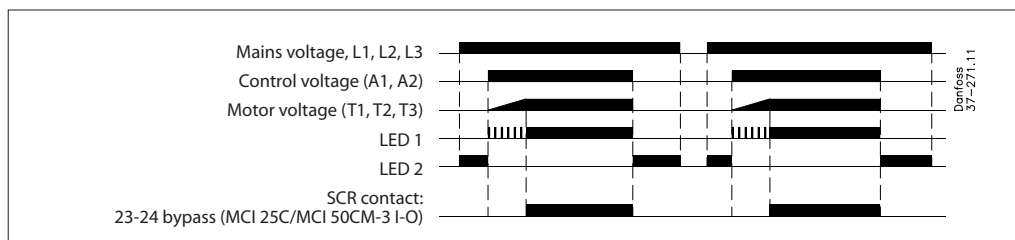

Functional description

Start

During ramp-up the controller will gradually increase the voltage to the motor from the preset initial torque value until it reaches full line voltage. The actual ramp time is digitally calculated and will not be influenced by net frequency or load variations.

Bypass mode (contact 23-24, only MCI 25C/ MCI 50CM-3 I-O)

The auxiliary contacts are made possible by means of SCR technology and will only switch correctly on a.c. current. The contact is intended for operating an external bypass contactor. The contact will close when the controller is in steady state operation, see application example page 7.

LED status indication

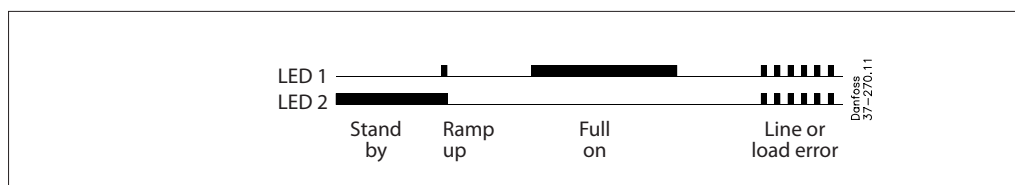

Soft starter selection guide

Performer® scroll compressors

Motor voltage code 4, 400 V - 3 phase - 50 Hz / 460 V - 3 phase - 60 Hz

Compressor model	Soft starter type Ambient temp. max. 40 °C	Soft starter type Ambient temp. max. 55 °C
SM/SZ 084	MCI 15C	MCI 15C
SM/SZ 090		MCI 25C
SM/SZ 100		
SM/SZ 110		
SM/SZ 115-125	MCI 25C	MCI 25C ¹⁾
SM/SZ 120		
SM/SZ 160		
SM/SZ 148-161		
SM/SZ 175-185		
SY/SZ 240	MCI 50CM-3 I-O ¹⁾	MCI 50CM-3 I-O ¹⁾
SY/SZ 300		
SZ 380	MCI 50CM-3 I-O ¹⁾	MCI 50CM-3 I-O ¹⁾

¹⁾ The controller must be by-passed in steady state mode. See application example page 7

Maneurop® compressors

Motor voltage code 4, 400 V - 3 phase - 50 Hz / 460 V - 3 phase - 60 Hz

Compressor model	Soft starter type Ambient temp. max. 40 °C	Soft starter type Ambient temp. max. 55 °C
MT/MTZ 18-22	MCI 15C	MCI 15C
MT/MTZ 28		
MT/MTZ 32		
MT/MTZ 36		
MT/MTZ 40		
MT/MTZ 44-50		
MT/MTZ 45-51		
MT/MTZ 56		
MT/MTZ 57-65		
MT/MTZ 64		
MT/MTZ 72-73-80-81		
MT/MTZ 100		MCI 25C
MT/MTZ 125		
MT/MTZ 144		
MT/MTZ 160		

¹⁾ The controller must be by-passed in steady state mode. See application example page 7

MCI C Soft Starter selection

Type	Operational voltage	Module dimensions	Code no.
	[V AC]	[mm]	
MCI 15C	380 – 480	45	037N0076
MCI 25C	380 – 480	90	037N0077
MCI 50CM-3 I-O	380 – 480	180	037N0401

Technical data

<i>Output specifications</i>		MCI 15C	MCI 25C	MCI 50CM-3 I-O
Operational voltage	V AC	380 – 480	380 – 480	380 – 480
Operational current (AC-3, AC-53a, AC-53b)	max.	15 A	25 A / 30 A	35 A / 50 A
Ramp up time (preset)	max.	0.4 s	0.4 s	0.5 s
Leakage current	max.	5 mA	5 mA	5 mA
Operational current	min.	50 mA	50 mA	50 mA
Overload relay trip class		Class 10	Class 10	Class 10
Semiconductor protection fusing:				
Type 1 ¹⁾ co-ordination		50 A gL/gG	100 A gL/gG	125 A gL/gG
Type 2 ²⁾ co-ordination	I ² t(t=10 ms)	1800 A ² S	6300 A ² S	25300 A ² S
Rating index:				
AC-53a Asynchronous motors ³⁾		15A: AC-53a: 8-3: 100-3000	25A: AC-53a: 8-3: 100-3000	35A: AC-53a: 6-6: 100-120
AC-53b Asynchronous motors with bypass		-	30A: AC-53b: 6-3: 30	50A: AC-53b: 6-3: 30

¹⁾ Type 1 coordination require that, under short-circuit conditions, the device shall cause no danger to persons or installation and may not be suitable for further use without repair and replacement of parts

²⁾ Type 2 coordination require that, under short-circuit conditions, the device shall cause no danger to persons or installation and shall be suitable for further use

³⁾ 15A: AC-53a: 8-3:100-3000 means max. load 8x15A for 3 seconds. 100% ON-load factor or 3000 operations per hour

Control circuit specifications

Control voltage range		24 – 480 V AC/DC		
Pick-up voltage	max.	20.4 V AC/DC		
Drop-out voltage	min.	5 V AC/DC		
Control current for no operation	max.	1 mA		
Control current / power	max.	15 mA / 2 VA		
Response time	max.	70 ms		
SCR by-pass contact, optional				
Voltage / current (AC-14, AC-15)	max.	24 – 240 V / 0.5A	24 – 240 V / 0.5A	24 – 240 V / 1.0A
Fuse	max.	10 A gL/gG, I ² t max. 72 A ² s		
EMC immunity		Meets requirements of EN 50082-1 and EN 500082-2		

Insulation

Rated insulation voltage U _i		660 V AC
Rated impulse withstand voltage U _{imp}		4 kV
Installation category		III

Thermal specification

Cooling method		Natural convection		
Mounting		Vertical +/- 30°		
Storage temperature range		-20 °C – 80 °C		
Enclosure degree / pollution degree		IP20 / 3	IP20 / 3	IP10 / 3
Power dissipation, continuous duty max.		2 W/A	2 W/A	3 W/A
Power dissipation, intermittent duty max.		2 W/A × duty cycle	2 W/A × duty cycle	3 W/A × duty cycle

Materials

Housing self extinguishing		PPO UL94V1
Heatsink aluminium		Black anodized
Base		Electroplated steel

Dimensions

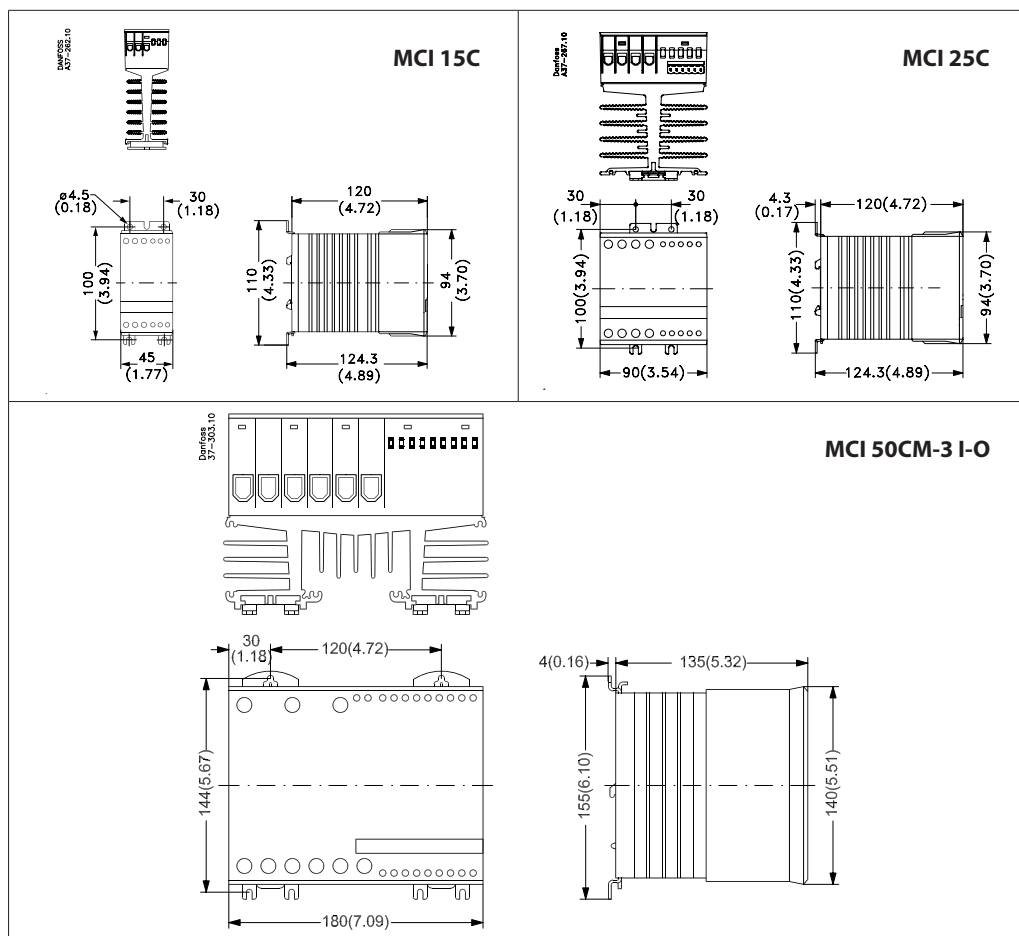

Mounting instructions

The controller is designed for vertical mounting. If the controller is mounted horizontally the load current must be reduced by 50%. The controller needs no side clearance. Clearance between two vertical mounted controller must be minimum 80 mm (3.15"). Clearance between controller and top and bottom walls must be minimum 30 mm (1.2").

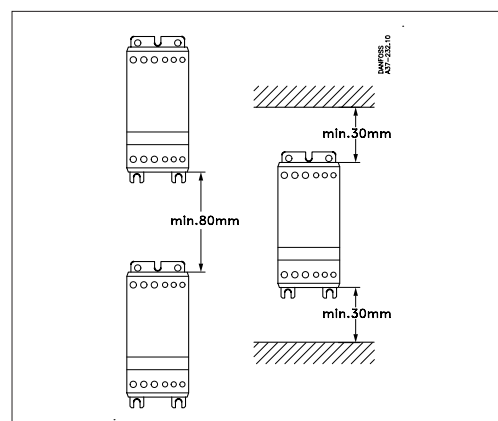

Overload and short circuit protection

Overload and short circuit protection is easily achieved by installing a circuit breaker on the line side of the motor controller. Select the circuit breaker from the table below.

Be aware of the maximum prospective short circuit current breaking capacity. For further information please refer to the data sheet on the circuit breaker.

Performer® scroll compressors

Motor voltage code 4 / 400 V - 3ph - 50 Hz / 460 V - 3ph - 60 Hz			
Compressor type	Compressor max. current [A]	Danfoss CTI	
		Type	Code no.
SM/SZ 084	17	CTI 25M	047B3150
SM/SZ 090	17	CTI 25M	047B3150
SM/SZ 100	19	CTI 25M	047B3151
SM/SZ 110	20	CTI 25M	047B3151
SM/SZ 115	25	CTI 25M	047B3152
SM/SZ 120	29	CTI 25M	047B3152
SM/SZ 125	25	CTI 25M	047B3152
SM/SZ 148	32	CTI 45MB	047B3164
SM/SZ 161	32	CTI 45MB	047B3164
SM/SZ 160	29	CTI 25M	047B3152
SM/SZ 175	35	CTI 45MB	047B3164
SM/SZ 185	35	CTI 45MB	047B3164
SY/SZ 240	50	CTI 45MB	047B3165

Maneurop® reciprocating compressors

Motor voltage code 4 / 400 V - 3ph - 50 Hz / 460 V - 3ph - 60 Hz			
Compressor type	Compressor max. current [A]	Danfoss CTI	
		Type	Code no.
MT/MTZ 18	5	CTI 25M	047B3147
MT/MTZ 22	6	CTI 25M	047B3148
MT/MTZ 28	7.5	CTI 25M	047B3148
MT/MTZ 32	8	CTI 25M	047B3149
MT/MTZ 36	9	CTI 25M	047B3149
MT/MTZ 40	10	CTI 25M	047B3149
MT/MTZ 44	9.5	CTI 25M	047B3149
MT/MTZ 45	9.5	CTI 25M	047B3149
MT/MTZ 50	12	CTI 25M	047B3150
MT/MTZ 51	11.5	CTI 25M	047B3149
MT/MTZ 56	12	CTI 25M	047B3150
MT/MTZ 57	12	CTI 25M	047B3150
MT/MTZ 64	15	CTI 25M	047B3150
MT/MTZ 65	14	CTI 25M	047B3150
MT/MTZ 72	15.5	CTI 25M	047B3150
MT/MTZ 73	17	CTI 25M	047B3150
MT/MTZ 80	18	CTI 25M	047B3151
MT/MTZ 81	19	CTI 25M	047B3151
MT/MTZ 100	22	CTI 25M	047B3151
MT/MTZ 125	27	CTI 25M	047B3152
MT/MTZ 144	30	CTI 45MB	047B3164
MT/MTZ 160	36	CTI 45MB	047B3164

Overheat protection

If required, the controller can be protected against overheating by inserting a thermostat in the slot on the right-hand side of the controller. Order: UP 62 thermostat, code no. **037N0050**
For wiring connections see application examples below.

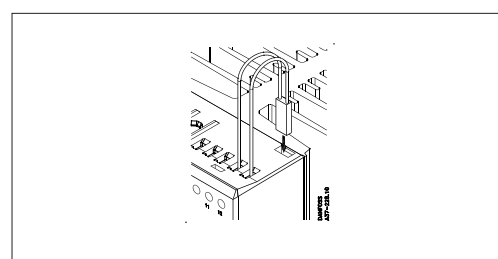

Application examples

Overheat protection

The thermostat is connected in series with the control circuit of the main contactor. When the temp. of the heat sink exceeds 90 °C the main contactor will be switched OFF. This circuit requires manual reset to restart the motor.

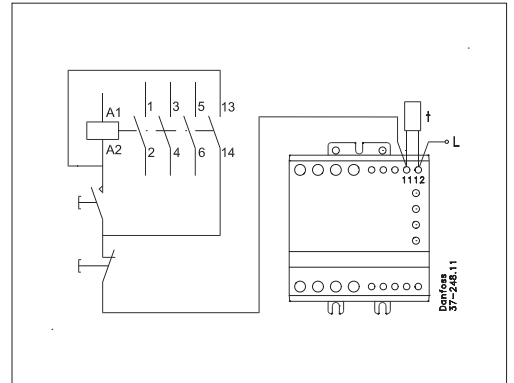

Line controlled soft start

When the contactor K1 is switched to the ON-state, the soft starter will start the motor, according to the settings of the ramp-up time and initial torque adjustments. When the contactor K1 is switched to the OFF-state the motor will be switched off instantaneously. In this application the contactor will have no load during operation. The contactor will carry and break the nominal motor current.

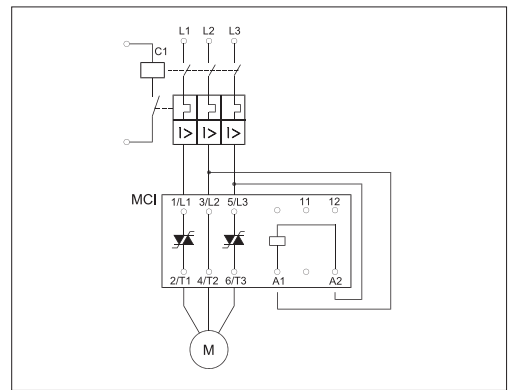

MCI 25 with bypass contactor

By means of the built-in auxiliary contact the bypass function is easily achieved, see wiring diagram from the side. No heat is generated from the MCI. As the contactor always switches in no-load condition it can be selected on the basis of the thermal current (AC-1). (13-14 contact not applicable with MCI 25C and MCI 50CM-3 I-O).

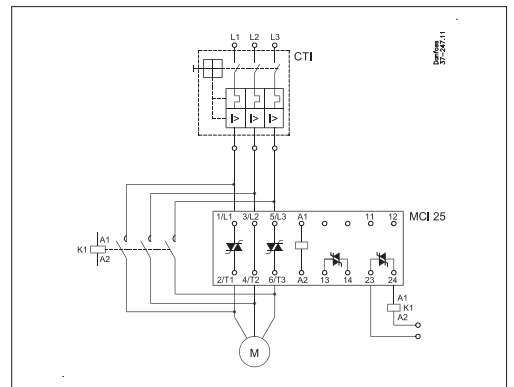

Input controlled soft start

When the control voltage is applied to A1 - A2, the MCI soft starter will start the motor, according to the settings of the Ramp-up time and Initial torque adjustments. When the control voltage is switched OFF, the motor will switch off instantaneously.

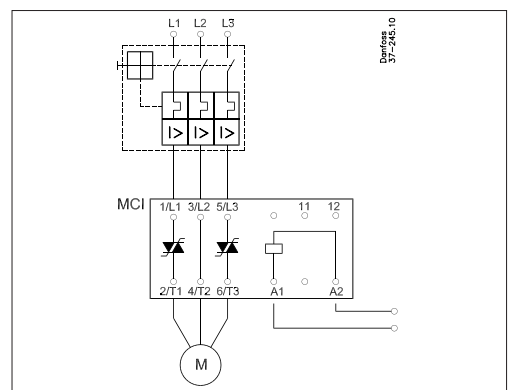

Danfoss can accept no responsibility for possible errors in catalogues, brochures and other printed material. Danfoss reserves the right to alter its products without notice. This also applies to products already on order provided that such alterations can be made without consequential changes being necessary in specifications already agreed. All trademarks in this material are property of the respective companies. Danfoss and the Danfoss logotype are trademarks of Danfoss A/S. All rights reserved.