

Dupline® Plug & Play Master Module Interface for Omron Type G 3496 0004



- Interface for Omron PLC with the function of a master
- Plug and play: Automatic communication with specific PLC/Controllers
- Built-in normal Dupline® Channel Generator
- 128 I/O's and DC power supply on 3 wires
- RS232/RS422/RS485 port for interfacing to control system
- Split-I/O mode selectable (128 inputs and 128 outputs)
- LED-indications for supply, Dupline® carrier and Com-port Tx
- Galvanically isolated Com-port supplied by internal DC/DC converter

Product Description

G 3496 0004 is designed as a cost-effective solution for interfacing Dupline® I/O's to a Omron PLC. It performs three functions: Dupline® channel

generator, power supply synchronization (enables 3-wire system with supply) and RS232/RS422/RS485 interface.

Ordering Key

G 3496 0004 700

Type: Dupline® _____
H4-Housing _____
Combined module _____
Interface type _____
DC supply _____

Type Selection

Supply	PLC Interface Conformance	Ordering no.
20-30 VDC	Omron CPM, CPM1A, CQM, SRM1 & C200	G 3496 0004 700

Input/Output Specifications

Power output	
Output voltage	20-30 VDC (pulsating)
Output current	< 3.0 A @ 50°C
Short circuit protection	4 A quick acting fuse
Output voltage drop	< 1.0 V
Dupline® carrier	
Output voltage	8.2 V (pulsating)
Current	< 60 mA
Short circuit protection	Yes
Scan time	
128 channels	132.2 ms
64 channels	69.8 ms
Communication port	
Standard	RS232/RS422/RS485
Split I/O mode	Yes, selectable
Normal Dupline mode	Yes, selectable
Connection	9 pole female Sub-D
Dielectric voltage	
Com-port Dupline®	1 kVAC (rms)
Protocol	HostLink
Baud rate	9600 (Omron Default) 19200
Data bits	7
Start bit	1
Stop bit	2
Parity	Even
Flow-control	None

Input/Output Specifications (Cont.)

Pin assignment	
2-wire RS 485	
S/R Data line + (B)	Pin 3
S/R Data line - (A)	Pin 8
GND	Pin 5
4-wire RS 485/RS 422	
R Data line + (B)	Pin 3
R Data line - (A)	Pin 8
S Data line + (B)	Pin 2
S Data line - (A)	Pin 7
Direction	Pin 4
	(Connect to GND pin 5 when using 4-wire communication)
RS 232	
TX	Pin 1
RX	Pin 9
GND	Pin 5

Supply Specifications

Power supply	Overvoltage cat. III (IEC 60664)
Operational voltage (V _{in})	20-30 VDC
Reverse polarity protection	None
Current consumption	< 150 mA + Power load
Power dissipation	< 5 W
Transient protection voltage	800 V
Dielectric voltage	
Supply - Dupline®	None
Supply - com-port	1 kVAC (rms)

General Specifications

Power ON delay	2 s	Humidity (non-condensing)	20 to 80%
Indication for Com-port Tx Supply ON Dupline® carrier	LED, red LED, green LED, yellow	Mechanical resistance Shock Vibration	15 G (11 ms) 2 G (6 to 55 Hz)
Environment Pollution degree Operating temperature Storage temperature	3 (IEC 60664) 0° to +50°C (+32° to +122°F) -50° to +85°C (-58° to +185°F)	Dimensions Material Weight	H4-Housing (see Technical information) 100 g

Mode of Operation

The Dupline® Master Module (DMM) controls a 3-wire bus with signal, DC-power and common GND. The DMM is connected to a standard DC-supply, which it synchronizes with the Dupline® carrier signal before it is output to supply. The synchronization is necessary in order to enable the Dupline® and DC-supply to share the GND-wire.

The Dupline® Master Module is a Dupline® Channel Generator with the function of a master.

This means that the 128 Dupline® I/O's will be read/written by the DMM and then sent to the PLC.

The DMM can run in two different modes – Normal mode and split I/O mode. In Normal mode, Dupline® operates as a peer-to-peer system, where the channel generator automatically establishes a connection between Dupline® inputs and Dupline® outputs which are coded to the same Dupline® address. If e.g. an

input coded for B5 is activated, the output(s) coded for B5 will also be activated.

Consequently, a Dupline®-output can either be activated through the output-data received on DMM or by an active Dupline® input coded for the same Dupline®-address. In "Split I/O" mode, the channel generator treats the Dupline® inputs and Dupline® outputs independently. If e.g. an input coded for B5 is activated, the DMM

will make the information available for the PLC (like in normal mode), but it will not automatically activate the Dupline® output(s) coded to B5. The Dupline® outputs are controlled exclusively through the output data received from the PLC. In this mode, up to 128 Dupline® inputs and 128 Dupline® outputs are available, since an input and an output coded to the same Dupline® address can operate independently.

Dip-Switch Setting

- Sw.3** **On:** 19200 baud
 Off: 9600 baud (Default Omron setting)
- Sw.4** **On:** Split I/O Channel Generator Mode
 (See "Mode of Operation")
 Off: Normal Dupline® Monostable Channel
 Generator Mode
- Sw.5** **On:** 64 Dupline® channels
 Off: 128 Dupline® channels

Memory Mapping

Table of the memory mapping to the PLC

Dupline® Channel	Omron		Dupline® Channel	Omron	
	Read	Write		Read	Write
A1	LR0000	LR0800	E1	LR0200	LR1000
A2	LR0001	LR0801	F1	LR0208	LR1008
A3	LR0002	LR0802	G1	LR0300	LR1100
A4	LR0003	LR0803	H1	LR0308	LR1108
A5	LR0004	LR0804	I1	LR0400	LR1200
A6	LR0005	LR0805	J1	LR0408	LR1208
A7	LR0006	LR0806	K1	LR0500	LR1300
A8	LR0007	LR0807	L1	LR0508	LR1308
B1	LR0008	LR0808	M1	LR0600	LR1400
B8	LR0015	LR0815	N1	LR0608	LR1408
C1	LR0100	LR0900	O1	LR0700	LR1500
D1	LR0108	LR0908	P1	LR0708	LR1508

Wiring Diagram

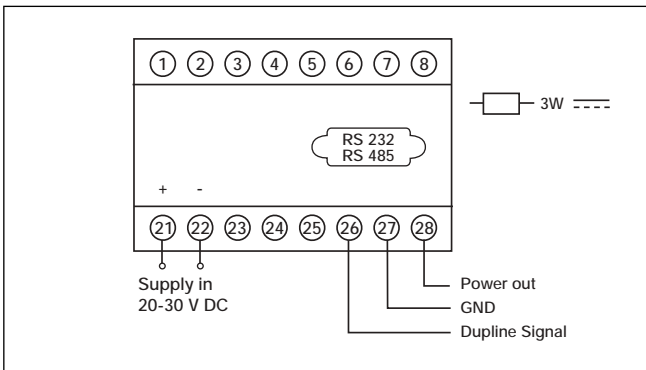

Pin Assignment

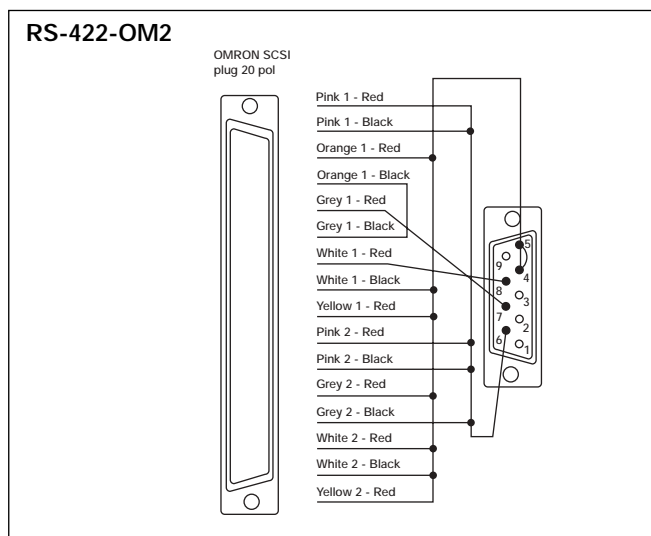
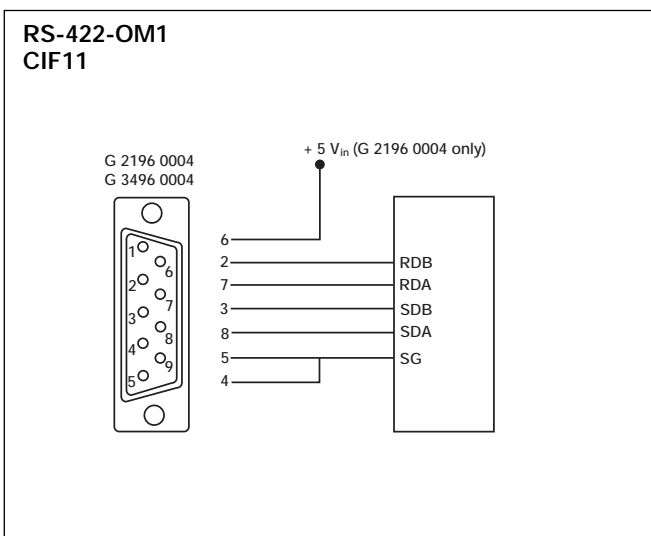

Accessories

Through Com. Module

Cable Sub-D 9M/6Wires for Com. Module with Screw term.

RS-422-OM1

Peripheral Port

Cable Sub-D 9M/SCSI

RS-422-OM2

Installation Hints

IMPORTANT

The PLC must be in Monitor-mode. Termination switch on CIF11 must be in OFF position

TX-LED

Slow flashing

No communication
Check the wiring.

Fast flashing

Communication OK.

No Dupline® Carrier-LED

Dupline® Short circuit

Short circuit between the two Dupline® wires.

Dimensions (mm)

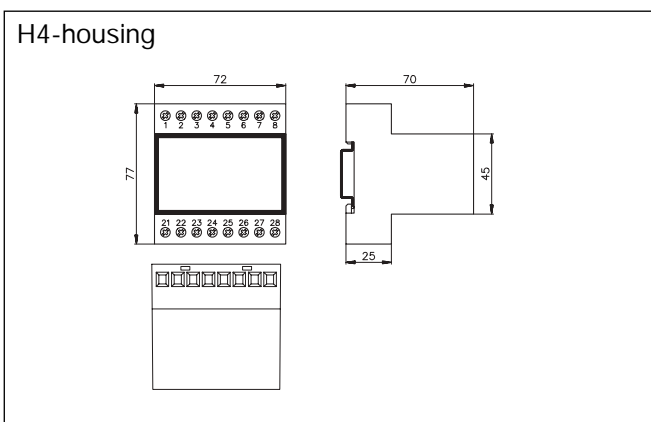

Additional Information

Scope of supply
1 x Master Module

G3496 0004 700