

Safety Modules

Light curtains

Types NLG02D, NLG13D

CARLO GAVAZZI



Screw, fixed



Screw, detachable

- Safety Category 4, Performance Level e, according to EN ISO 13849-1
- 2 x 6 A NO safety outputs (NLG02D)
- 3 x 6 A NO safety outputs and 1 x 6 A NC auxiliary output (NLG13D)
- Automatic / manual or monitored manual reset
- Single / double channel operations
- LED indication for outputs status and power supply ON
- Connection by fixed or detachable terminals
- For mounting on DIN-rail in accordance with DIN/EN 50 022
- 22.5 mm Euronorm housing

Product Description

NLG02D and NLG13D are safety modules designed to monitor safety light curtains with PNP or relay outputs according to 2006/42/EC Machinery Directive. This family of safety mod-

ules in Safety Category 4, Performance Level e, includes fixed screw and detachable screw as well as automatic/manual or monitored manual restart versions.

Ordering Key

N LG 0 2 D 724 S A

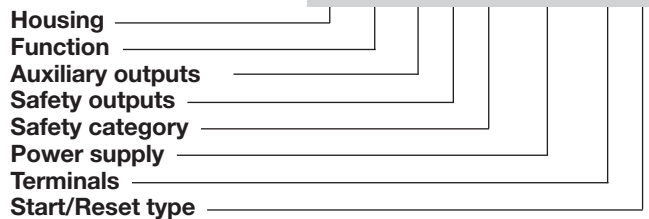

Type Selection

Auxiliary outputs	Safety outputs	Terminals	Start/Reset type	Supply: 24 VDC
	2 NO	Screw, fixed	Automatic / Manual	N LG 0 2 D 724 S A
	2 NO	Screw, fixed	Monitored manual	N LG 0 2 D 724 S C
	2 NO	Screw, detachable	Automatic / Manual	N LG 0 2 D 724 D A
	2 NO	Screw, detachable	Monitored manual	N LG 0 2 D 724 D C
1 NC	3 NO	Screw, fixed	Automatic / Manual	N LG 1 3 D 724 S A
1 NC	3 NO	Screw, fixed	Monitored manual	N LG 1 3 D 724 S C
1 NC	3 NO	Screw, detachable	Automatic / Manual	N LG 1 3 D 724 D A
1 NC	3 NO	Screw, detachable	Monitored manual	N LG 1 3 D 724 D C

Time Specifications

Delay ON energisation	< 150 ms
Delay ON de-energisation	< 30 ms
Channel simultaneity during outputs closing	Infinite
Input operating to START operating delay NLG...C	> 500 ms

Input specifications

Function	2 NO
Input current/voltage NLG02D Terminals S12-S21	min 10 mA / 17 V max 60 mA / 38 V
NLG13D Terminals S11-S22	min 10 mA / 17 V max 30 mA / 38 V

Output Specifications

Safety outputs	Category 4, Performance Level e (EN ISO 13849-1)
NLG02D	2 NO (13-14, 23-24)
NLG13D	3 NO (13-14, 23-24, 33-34)
Auxiliary output NLG13D	1 NC (41-42)
Rated insulation voltage	250 VAC (rms)
Contact ratings (AgSnO ₂)	2 µm Au
Resistive loads	AC1 6 A @ 230 VAC DC12 6 A @ 24 VDC
Small inductive loads	AC15 3 A @ 230 VAC DC13 2.5 A @ 24 VDC
External contact fuse protection	5 A fast, 4 A slow
Mechanical life	> 10 ⁷ operations
Electrical life	> 10 ⁵ operations
Dielectric strength Dielectric voltage	4 kVAC (rms)



Supply Specifications

Power supply Rated operational voltage through terminals: A1, A2	Overvoltage cat. III (IEC 60664) 24 VDC -15% / +10%	
Short circuit protection	Internal PTC	
Dielectric voltage Supply to input Supply to output Input to output	DC supply none 4 kV 4 kV	AC supply none 4 kV 4 kV
Rated operational power	max 4 W	

General Specifications

Indication for Power supply ON Output relays ON	LED, green LED, green (CH 1, 2)
Environment Degree of protection Pollution degree Operating temperature Storage temperature	(EN 60529) IP 30 2 -25 to 65°C, R.H. < 95% -30 to 65°C, R.H. < 95%
Minimum protection degree of the installation location	IP 54
Housing dimensions	22.5 x 99 x 114 mm
Weight	Approx. 200 g
Screw terminals Tightening torque Upper terminals Lower terminals	Max. 0.5 Nm Max. 0.8 Nm
Approvals	cULus, TUV
CE Marking	Yes
EMC Immunity Emission	Electromagnetic Compatibility According to EN 61000-6-2 According to EN 61000-6-3

Mode of Operation

The safety modules NLG02D and NLG13D monitor ElectroSensitive Equipments (ESPE) with PNP or relay outputs according to 2006/42/EC Machinery Directive.

If the safety system (NLG+ESPE) is correctly supplied, the input terminals of the module are activated (light beams not interrupted) and there aren't fault conditions, the module is enabled to close the safety outputs and the external contactors can be energized.

When the input terminals are not activated (light beams interrupted) the module is not enabled to close the safety outputs and the external contactors can not be energized.

Automatic START

Provided that the terminals X1 and X2 (NLG02...A) or S33 and S34 (NLG13...A) are connected, the safety outputs close and the auxiliary output opens (NLG13...A) as soon as both the module inputs are activated. The relevant CH1 and CH2 LED turn on.

Deactivating even one module input forces immediately the safety outputs to open and the auxiliary output (NLG13...A) to close.

A new operating cycle is possible only after deactivating both input contacts and then operating them again.

Manual START

Provided that both the module inputs are activated, the safety outputs close and the auxiliary output opens (NLG13...A) as soon as the NO START pushbutton is pushed connecting X1 and X2 (NLG02...A) or S33 and S34 (NLG13...A).

A new operating cycle is possible only after deactivating both the module inputs, activating them again and pushing the START button.

Monitored manual START

The monitored manual START versions (NLG...C) work as described in the previous paragraph (Manual START) except for a minimum delay of 500 ms from the activated status of the module inputs to the pushing of the START button.

If the inputs of the module are closed with the START switch already closed, the safety outputs don't close and the auxiliary doesn't open (NLG13...C): it is necessary to release the START button and deactivate the module inputs before starting a new cycle, then operate the inputs of the module and finally, after at least 500 ms, operate the START button.

So if the NO START button gets welded, the outputs don't close anymore.

Operation Diagrams

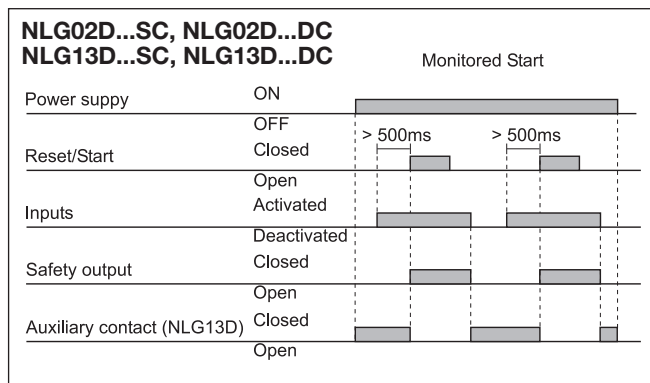
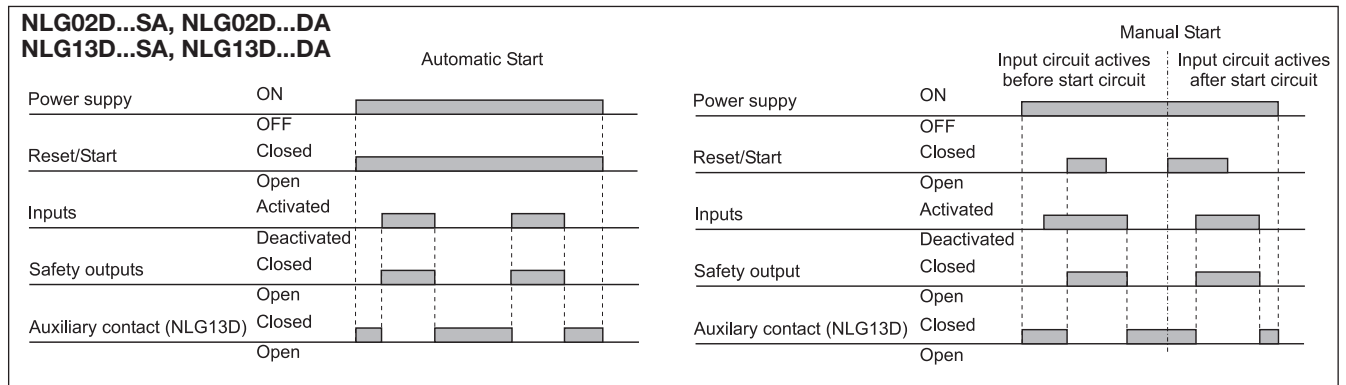

Wiring Diagrams

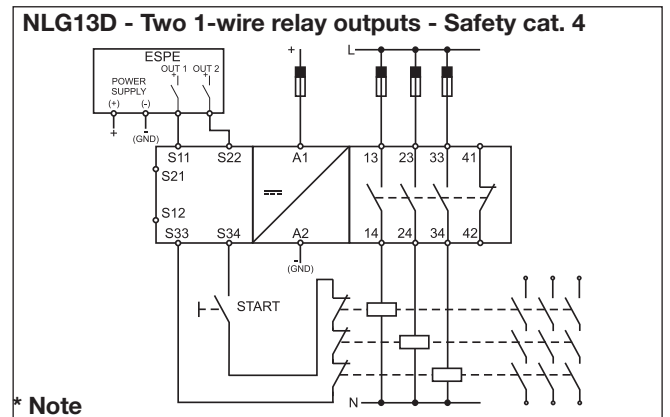
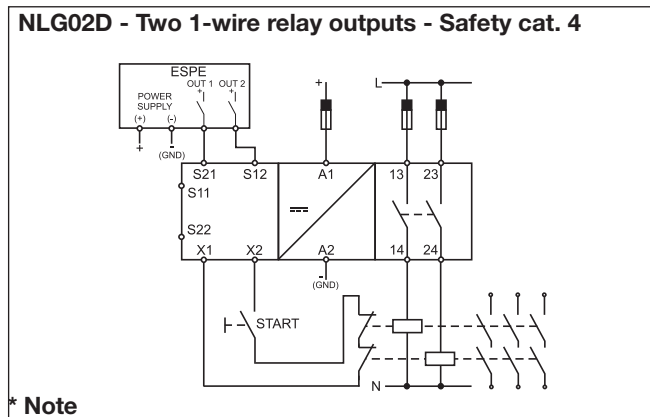
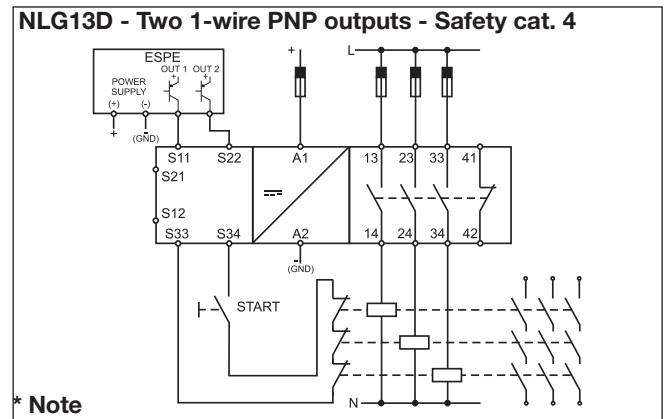
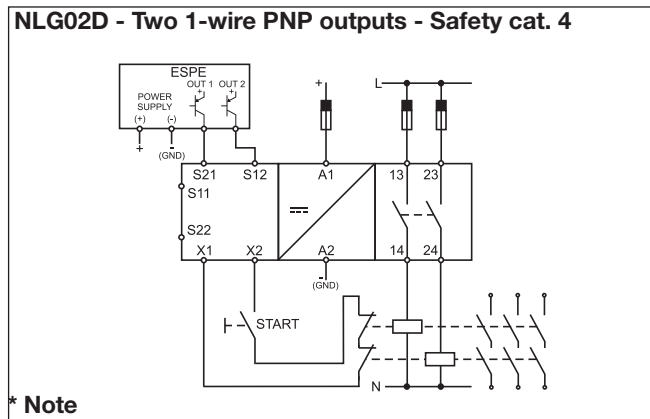

*** Note:** The same power supply has to be used both for the module and for the light curtain.



Wiring Diagrams (cont.)

NLG02D - One 1-wire PNP output - Safety cat. 2

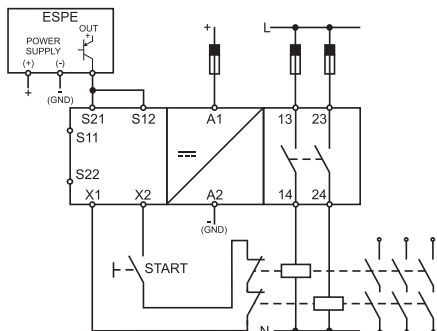

* Note

NLG13D - One 1-wire PNP output - Safety cat. 2

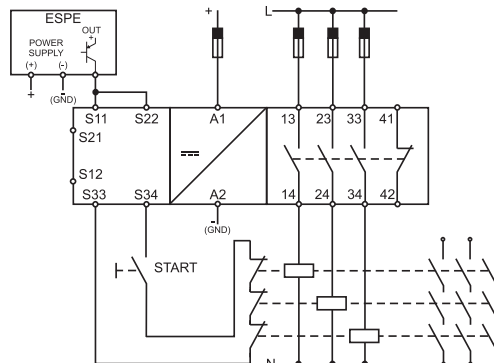

* Note

NLG02D - One 1-wire relay output - Safety cat. 2

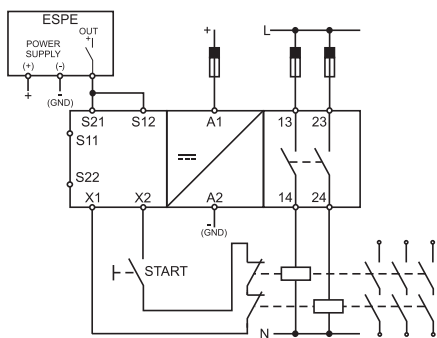

* Note

NLG13D - One 1-wire relay output - Safety cat. 2

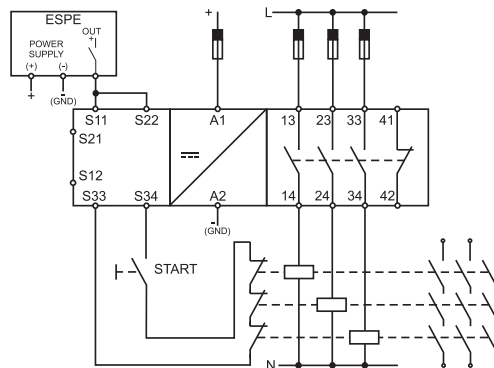

* Note

NLG02D - Two 2-wire PNP outputs - Safety cat. 4

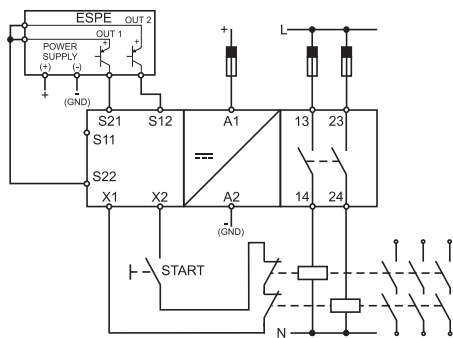

NLG13D - Two 2-wire PNP outputs - Safety cat. 4

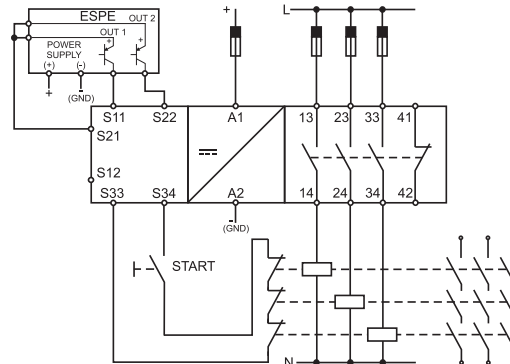

NLG02D - Two 2-wire relay outputs - Safety cat. 4

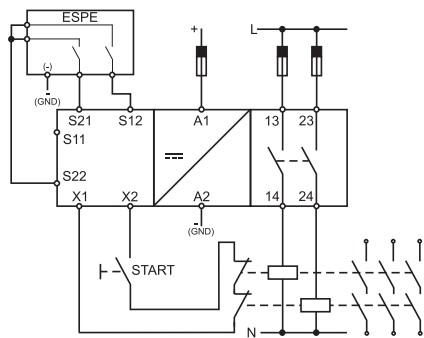

NLG13D - Two 2-wire relay outputs - Safety cat. 4

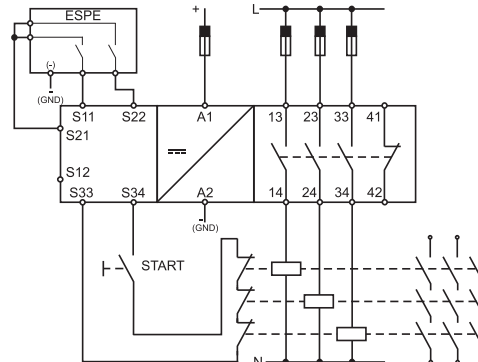

* Note: The same power supply has to be used both for the module and for the light curtain.

Wiring Diagrams (cont.)

NLG02D - One 2-wire PNP output - Safety cat. 2

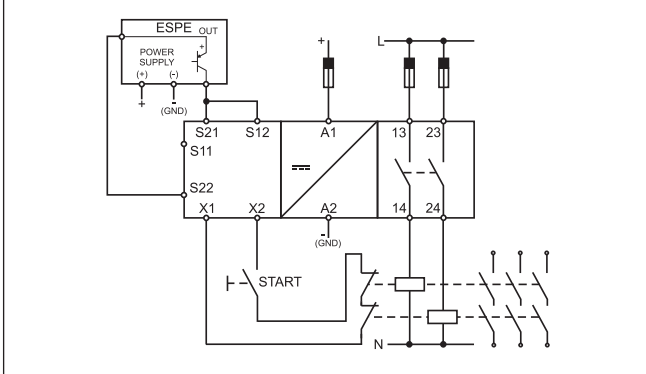

NLG13D - One 2-wire PNP output - Safety cat. 2

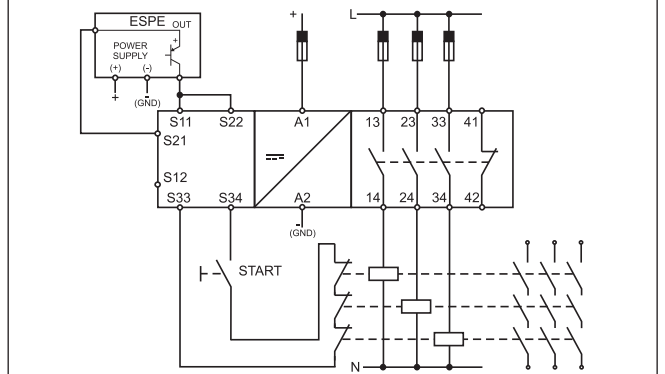

NLG02D - One 2-wire relay output - Safety cat. 2

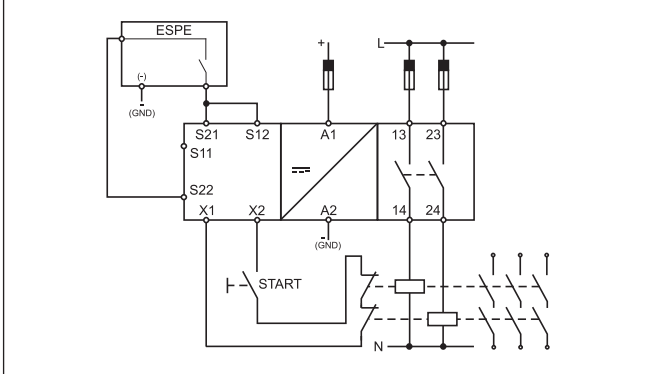

NLG13D - One 2-wire relay output - Safety cat. 2

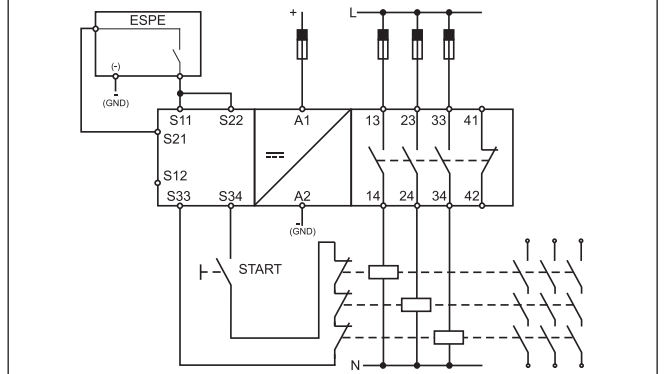

Dimensions

Versions with fixed terminals

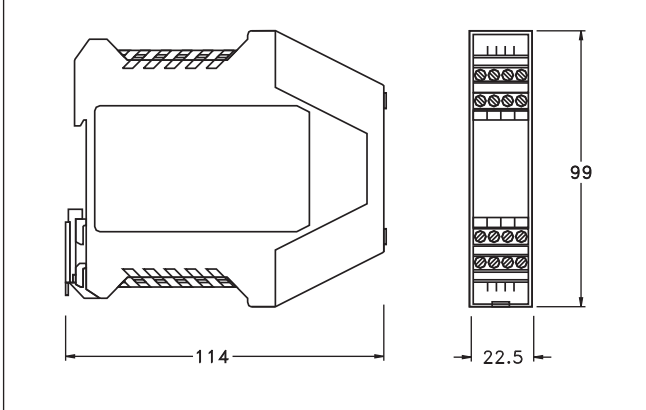

Versions with detachable terminals

