

Modelli disponibili

Cavi I/O

Forma	Collegamento PLC	Collegamento dei terminali	Lunghezza in cm										Cablaggio	Modello
			30	50	75	100	150	200	250	300	400	500		
	FCN24	MIL20	-	■	-	■	-	■	-	■	-	-	Diritto	XW2Z-[...]AD-L
		Estremità aperte	-	-	-	■	-	■	-	■	-	-	nd	XW2Z-[...]AL-L
	FCN40	MIL20 x 2	-	-	-	■	■	■	-	■	■	■	Diritto	XW2Z-[...]BH-L01
													Indietro	XW2Z-[...]BH-L02
		MIL40	-	■	-	■	■	■	-	■	-	■	Diritto	XW2Z-[...]BF-L
		Estremità aperte	-	-	-	■	-	■	-	■	-	■	nd	XW2Z-[...]BN-L
	FCN56	MIL20 x 3	-	-	-	-	■	■	-	■	-	-	Diritto	XW2Z-[...]CJ-L01
													Indietro	XW2Z-[...]CJ-L02
		MIL20 + MIL40	-	-	-	-	■	■	-	-	-	-	Diritto	XW2Z-[...]CK-L01
													Indietro	XW2Z-[...]CK-L02
		MIL60	-	-	-	■	-	■	-	■	-	-	Diritto	XW2Z-[...]CG-L
	MIL20	MIL20	-	■	-	■	-	■	-	-	-	-	Diritto	XW2Z-[...]DD-L
		Estremità aperte	-	■	-	■	■	■	-	■	-	■	nd	XW2Z-[...]DL-L
		Terminali a forcella	-	■	-	■	■	■	-	■	-	■	nd	XW2Z-[...]DM-L
	MIL34	MIL34	-	-	-	-	-	■	-	-	-	-	Diritto	XW2Z-[...]EE-L
	MIL40	MIL20 x 2	-	-	■	■	-	■	-	■	-	■	Indietro	XW2Z-[...]FH-L01
													Diritto	XW2Z-[...]FH-L02
		MIL40	■	■	-	■	■	■	-	■	-	■	Diritto	XW2Z-[...]FF-L
		Estremità aperte	-	-	-	■	■	■	■	■	-	■	nd	XW2Z-[...]FN-L

Nota: Per [...] inserire la lunghezza a 4 cifre in cm.

Cavi I/O XW2Z

XW2Z-AD-L

Collegamento PLC	Collegamento dei terminali	Cablaggio	Lunghezza in cm (L)									Modello	
			30	50	75	100	150	200	250	300	400		500
Connettore FCN a 24 pin	Connettore MIL a 20 pin	Diritto	-	■	-	-	-	-	-	-	-	-	XW2Z-0050AD-L
			-	-	-	■	-	-	-	-	-	-	XW2Z-0100AD-L
			-	-	-	-	-	■	-	-	-	-	XW2Z-0200AD-L
			-	-	-	-	-	-	-	■	-	-	XW2Z-0300AD-L

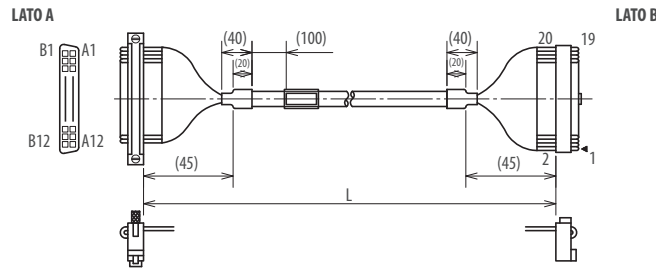

XW2Z-AL-L

Collegamento PLC	Collegamento dei terminali	Cablaggio	Lunghezza in cm (L)									Modello	
			30	50	75	100	150	200	250	300	400		500
FCN a 24 pin	Fili liberi	Diritto	-	-	-	■	-	-	-	-	-	-	XW2Z-0100AL-L
			-	-	-	-	-	■	-	-	-	-	XW2Z-0200AL-L
			-	-	-	-	-	-	-	■	-	-	XW2Z-0300AL-L

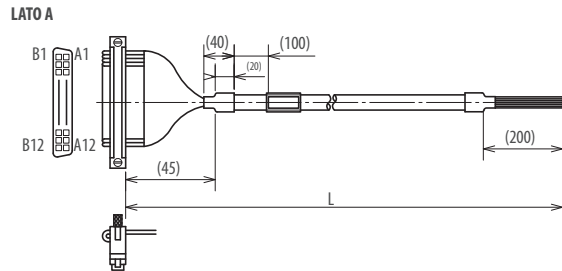

XW2Z-BH-L01

Collegamento PLC	Collegamento dei terminali	Cablaggio	Lunghezza in cm (L1)					Lunghezza in cm (L2)					Modello			
			100	150	200	300	400	500	75	125	175	275		375	475	
FCN a 40 pin	Due MIL a 20 pin	Diritto	■	-	-	-	-	-	■	-	-	-	-	-	XW2Z-0100BH-L01	
			-	■	-	-	-	-	-	■	-	-	-	-	XW2Z-0150BH-L01	
			-	-	■	-	-	-	-	-	■	-	-	-	-	XW2Z-0200BH-L01
			-	-	-	■	-	-	-	-	-	■	-	-	-	XW2Z-0300BH-L01
			-	-	-	-	■	-	-	-	-	-	■	-	-	XW2Z-0400BH-L01
			-	-	-	-	-	■	-	-	-	-	-	■	-	XW2Z-0500BH-L01

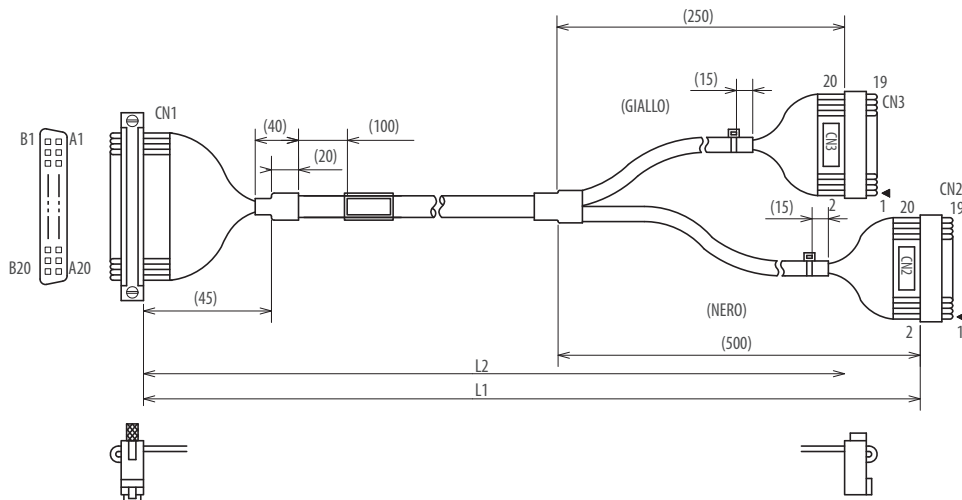

XW2Z-\_BH-L02

Collegamento PLC	Collegamento dei terminali	Cablaggio	Lunghezza in cm (L1)					Lunghezza in cm (L2)					Modello			
			100	150	200	300	400	500	75	125	175	275		375	475	
FCN a 40 pin	Due MIL a 20 pin	Indietro	■	-	-	-	-	-	■	-	-	-	-	-	XW2Z-0100BH-L02	
			-	■	-	-	-	-	-	■	-	-	-	-	XW2Z-0150BH-L02	
			-	-	■	-	-	-	-	-	-	■	-	-	-	XW2Z-0200BH-L02
			-	-	-	■	-	-	-	-	-	-	■	-	-	XW2Z-0300BH-L02
			-	-	-	-	■	-	-	-	-	-	-	■	-	XW2Z-0400BH-L02
			-	-	-	-	-	■	-	-	-	-	-	-	■	XW2Z-0500BH-L02

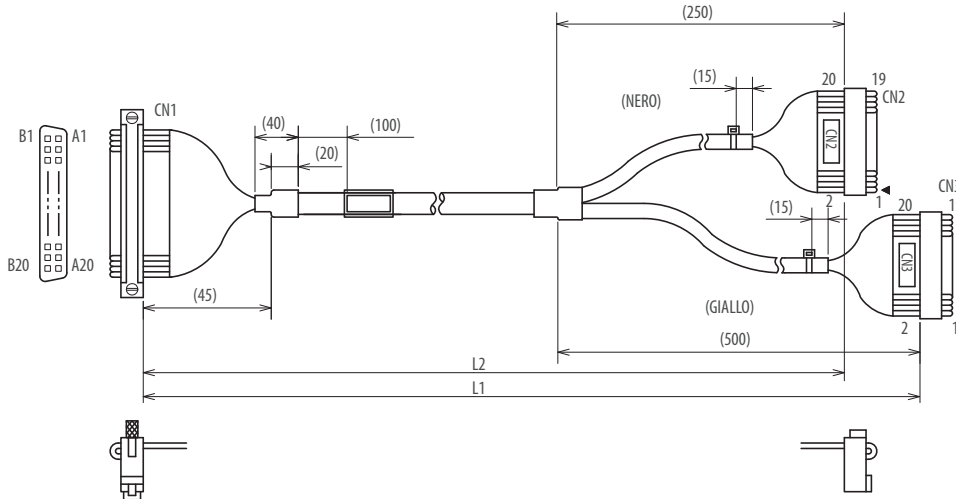

XW2Z-\_BF-L

Collegamento PLC	Collegamento dei terminali	Cablaggio	Lunghezza in cm (L)										Modello			
			30	50	75	100	150	200	250	300	400	500				
FCN a 40 pin	MIL a 40 pin	Dritto	-	■	-	-	-	-	-	-	-	-	-	XW2Z-0050BF-L		
			-	-	■	-	-	-	-	-	-	-	-	-	XW2Z-0100BF-L	
			-	-	-	■	-	-	-	-	-	-	-	-	-	XW2Z-0150BF-L
			-	-	-	-	■	-	-	-	-	-	-	-	-	XW2Z-0200BF-L
			-	-	-	-	-	-	■	-	-	-	-	-	-	XW2Z-0300BF-L
			-	-	-	-	-	-	-	■	-	-	-	-	-	XW2Z-0500BF-L

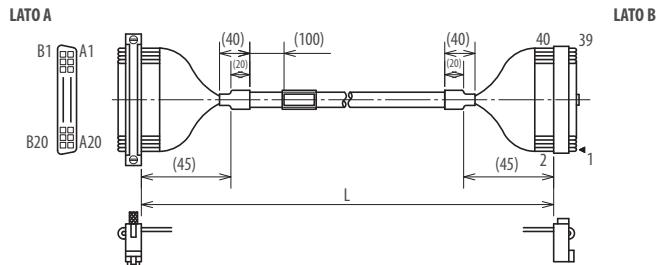

XW2Z-\_BN-L

Collegamento PLC	Collegamento dei terminali	Cablaggio	Lunghezza in cm (L)										Modello		
			30	50	75	100	150	200	250	300	400	500			
FCN a 40 pin	Fili liberi	Dritto	-	-	-	■	-	-	-	-	-	-	-	XW2Z-0100BN-L	
			-	-	-	-	■	-	-	-	-	-	-	-	XW2Z-0200BN-L
			-	-	-	-	-	-	■	-	-	-	-	-	XW2Z-0300BN-L
			-	-	-	-	-	-	-	-	■	-	-	-	XW2Z-0500BN-L

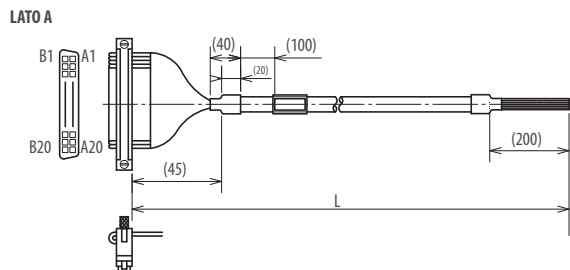

XW2Z-\_CJ-L01

Collegamento PLC	Collegamento dei terminali	Cablaggio	Lunghezza in cm (L1)					Lunghezza in cm (L2)					Modello		
			100	150	200	300	400	500	75	125	175	275		375	475
FCN a 56 pin	Tre MIL a 20 pin	Diritto	-	■	-	-	-	-	-	■	-	-	-	-	XW2Z-0150CJ-L01
			-	-	■	-	-	-	-	-	■	-	-	-	XW2Z-0200CJ-L01
			-	-	-	■	-	-	-	-	-	■	-	-	XW2Z-0300CJ-L01

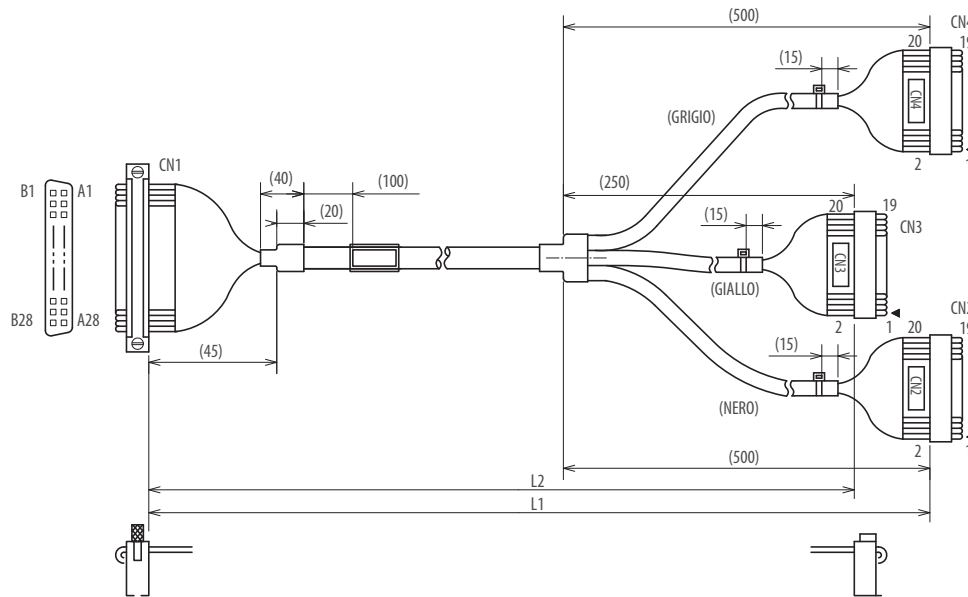

XW2Z-\_CJ-L02

Collegamento PLC	Collegamento dei terminali	Cablaggio	Lunghezza in cm (L1)					Lunghezza in cm (L2)					Lunghezza in cm (L3)			Modello					
			100	150	200	300	400	500	75	125	175	275	375	475	50		100	150	250	300	
FCN a 56 pin	Tre MIL a 20 pin	Indietro	-	■	-	-	-	-	-	■	-	-	-	-	-	■	-	-	-	XW2Z-0150CJ-L02	
			-	-	■	-	-	-	-	-	■	-	-	-	-	-	■	-	-	-	XW2Z-0200CJ-L02
			-	-	-	■	-	-	-	-	-	■	-	-	-	-	-	■	-	-	XW2Z-0300CJ-L02

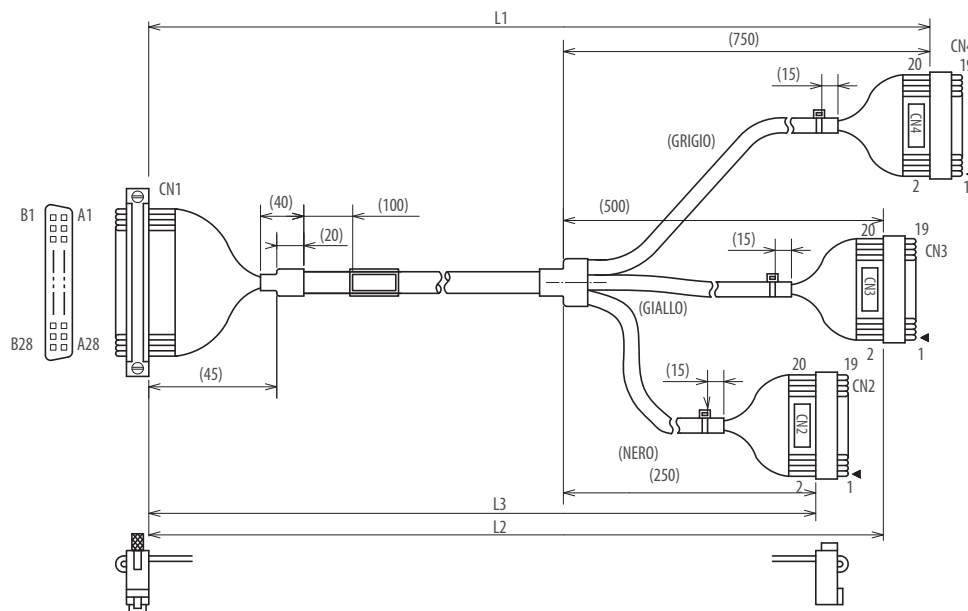

XW2Z-CK-L0\_

Collegamento PLC	Collegamento dei terminali	Cablaggio	Lunghezza in cm (L1)					Lunghezza in cm (L2)					Modello		
			100	150	200	300	400	500	75	125	175	275		375	475
56 pin	MIL a 40 pin	Diritto	-	■	-	-	-	-	-	■	-	-	-	-	XW2Z-0150CK-L01
		Indietro	-	■	-	-	-	-	-	■	-	-	-	-	XW2Z-0150CK-L02
		Diritto	-	-	■	-	-	-	-	-	■	-	-	-	XW2Z-0200CK-L01
		Indietro	-	-	■	-	-	-	-	-	■	-	-	-	XW2Z-0200CK-L02

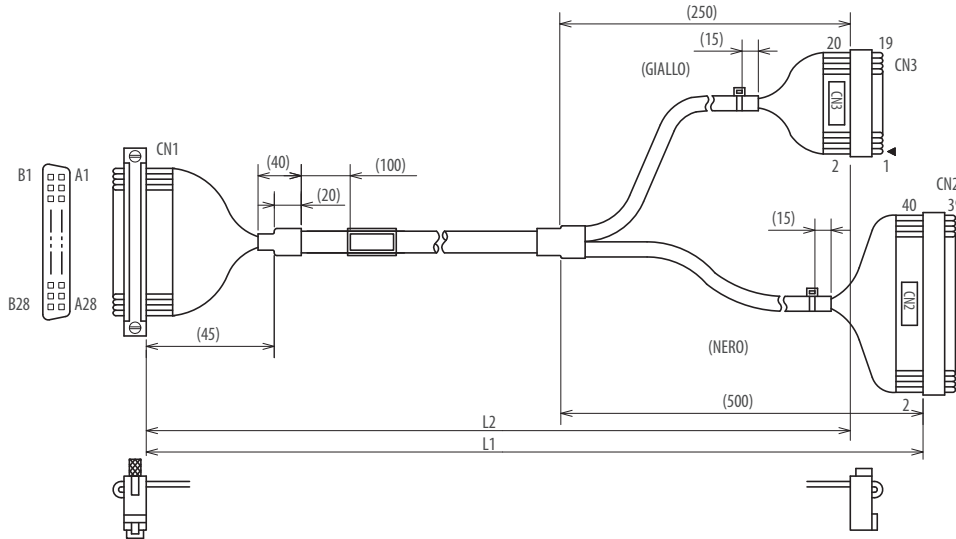

XW2Z-CG-L

Collegamento PLC	Collegamento dei terminali	Cablaggio	Lunghezza in cm (L)							Modello				
			30	50	75	100	150	200	250		300	400	500	
FCN a 56 pin	MIL a 60 pin	Diritto	-	-	-	■	-	-	-	-	-	-	-	XW2Z-0100CG-L
			-	-	-	-	-	■	-	-	-	-	-	XW2Z-0200CG-L
			-	-	-	-	-	-	-	■	-	-	-	-

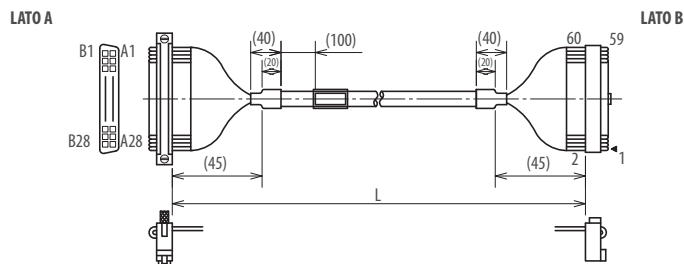

XW2Z-DD-L

Collegamento PLC	Collegamento dei terminali	Cablaggio	Lunghezza in cm (L)							Modello				
			30	50	75	100	150	200	250		300	400	500	
MIL a 20 pin	MIL a 20 pin	Diritto	-	■	-	-	-	-	-	-	-	-	-	XW2Z-0050DD-L
			-	-	-	■	-	-	-	-	-	-	-	XW2Z-0100DD-L
			-	-	-	-	-	■	-	-	-	-	-	XW2Z-0200DD-L

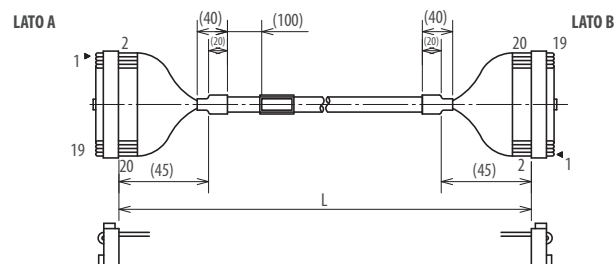

XW2Z-\_DL-L

Collegamento PLC	Collegamento dei terminali	Cablaggio	Lunghezza in cm (L1)										Modello	
			30	50	75	100	150	200	250	300	400	500		
MIL a 20 pin	Fili liberi	Diritto	-	■	-	-	-	-	-	-	-	-	-	XW2Z-0050DL-L
			-	-	-	■	-	-	-	-	-	-	-	XW2Z-0100DL-L
			-	-	-	-	■	-	-	-	-	-	-	XW2Z-0150DL-L
			-	-	-	-	-	■	-	-	-	-	-	XW2Z-0200DL-L
			-	-	-	-	-	-	■	-	-	-	-	XW2Z-0300DL-L
			-	-	-	-	-	-	-	■	-	-	-	XW2Z-0500DL-L

LATO A

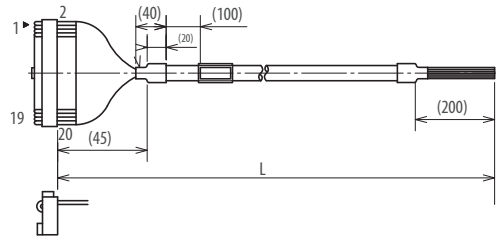

XW2Z-\_DM-L

Collegamento PLC	Collegamento dei terminali	Cablaggio	Lunghezza in cm (L1)										Modello	
			30	50	75	100	150	200	250	300	400	500		
MIL a 20 pin	Fili liberi con terminali a forcella	Diritto	-	■	-	-	-	-	-	-	-	-	-	XW2Z-0050DM-L
			-	-	-	■	-	-	-	-	-	-	-	XW2Z-0100DM-L
			-	-	-	-	■	-	-	-	-	-	-	XW2Z-0150DM-L
			-	-	-	-	-	■	-	-	-	-	-	XW2Z-0200DM-L
			-	-	-	-	-	-	■	-	-	-	-	XW2Z-0300DM-L
			-	-	-	-	-	-	-	■	-	-	-	XW2Z-0500DM-L

LATO A

LATO B

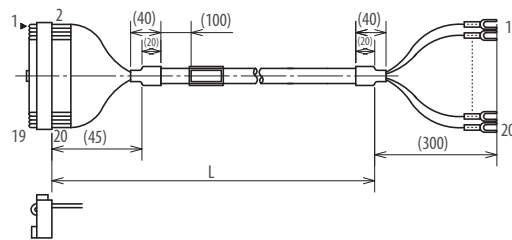

XW2Z-0200EE-L

Collegamento PLC	Collegamento dei terminali	Cablaggio	Lunghezza in cm (L1)										Modello	
			30	50	75	100	150	200	250	300	400	500		
MIL a 34 pin	MIL a 34 pin	Diritto	-	-	-	-	-	■	-	-	-	-	-	XW2Z-0200EE-L

LATO A

LATO B

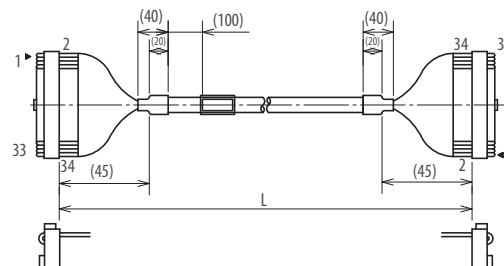

XW2Z-\_FH-L01

Collegamento PLC	Collegamento dei terminali	Cablaggio	Lunghezza in cm (L1)					Lunghezza in cm (L2)					Modello		
			75	100	200	300	400	500	50	75	175	275		375	475
MIL a 40 pin	Due MIL a 20 pin	Indietro	■	-	-	-	-	-	■	-	-	-	-	-	XW2Z-0075FH-L01
			-	■	-	-	-	-	-	■	-	-	-	-	XW2Z-0100FH-L01
			-	-	■	-	-	-	-	-	-	■	-	-	XW2Z-0200FH-L01
			-	-	-	■	-	-	-	-	-	-	■	-	XW2Z-0300FH-L01
			-	-	-	-	-	■	-	-	-	-	-	-	■

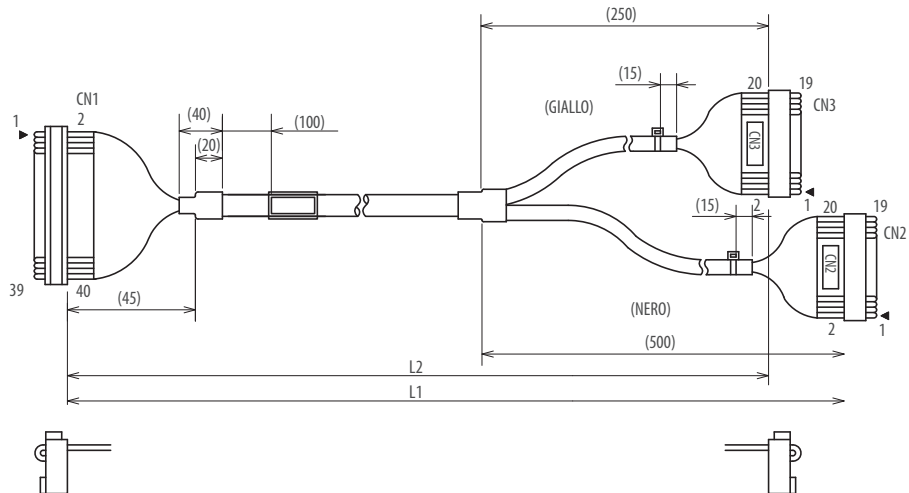

XW2Z-\_FH-L02

Collegamento PLC	Collegamento dei terminali	Cablaggio	Lunghezza in cm (L1)					Lunghezza in cm (L2)					Modello			
			75	100	200	300	400	500	50	75	175	275		375	475	
MIL a 40 pin	Due MIL a 20 pin	Diritto	■	-	-	-	-	-	■	-	-	-	-	-	XW2Z-0075FH-L02	
			-	■	-	-	-	-	-	■	-	-	-	-	XW2Z-0100FH-L02	
			-	-	■	-	-	-	-	-	-	■	-	-	-	XW2Z-0200FH-L02
			-	-	-	■	-	-	-	-	-	-	■	-	-	XW2Z-0300FH-L02
			-	-	-	-	-	■	-	-	-	-	-	-	■	XW2Z-0500FH-L02

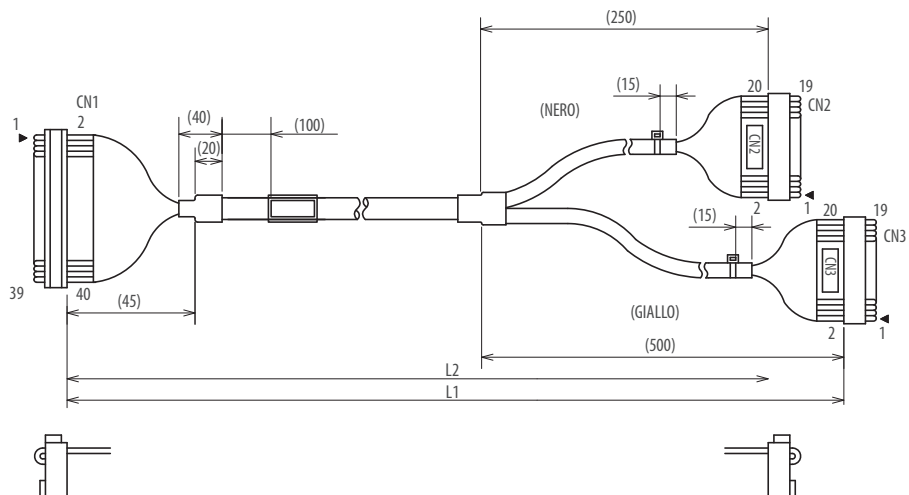

XW2Z-\_FF-L

Collegamento PLC	Collegamento dei terminali	Cablaggio	Lunghezza in cm (L1)								Modello			
			30	50	75	100	150	200	250	300		400	500	
MIL a 40 pin	MIL a 40 pin	Diritto	■		-	-	-	-	-	-	-	-	XW2Z-0030FF-L	
			-	■	-	-	-	-	-	-	-	-	XW2Z-0050FF-L	
			-	-	-	■	-	-	-	-	-	-	-	XW2Z-0100FF-L
			-	-	-	-	■	-	-	-	-	-	-	XW2Z-0150FF-L
			-	-	-	-	-	■	-	-	-	-	-	XW2Z-0200FF-L
			-	-	-	-	-	-	■	-	-	-	-	XW2Z-0300FF-L
			-	-	-	-	-	-	-	■	-	-	-	XW2Z-0500FF-L

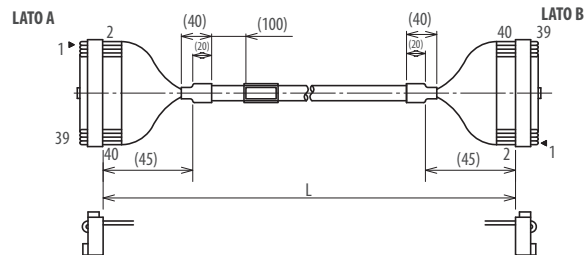

XW2Z-\_FN-L

Collegamento PLC	Collegamento dei terminali	Cablaggio	Lunghezza in cm (L1)								Modello			
			30	50	75	100	150	200	250	300		400	500	
MIL a 40 pin	Fili liberi	Diritto	-	-	-	■	-	-	-	-	-	-	XW2Z-0100FN-L	
			-	-	-	-	■	-	-	-	-	-	XW2Z-0150FN-L	
			-	-	-	-	-	■	-	-	-	-	XW2Z-0200FN-L	
			-	-	-	-	-	-	■	-	-	-	XW2Z-0250FN-L	
			-	-	-	-	-	-	-	■	-	-	-	XW2Z-0300FN-L
			-	-	-	-	-	-	-	-	■	-	-	XW2Z-0500FN-L

