



**Automatización Eléctrica**  
Especialistas en Automatización

At the end of this document you will find links to products related to this catalog. You can go directly to our shop by clicking HERE. [HERE](#)

## Electronic housing - EMG150-LG/O - 2906571

Please be informed that the data shown in this PDF Document is generated from our Online Catalog. Please find the complete data in the user's documentation. Our General Terms of Use for Downloads are valid (<http://phoenixcontact.com/download>)



Electronic housing, for PCB insertion, without screw connection terminal blocks and cover, with open terminal space

### Why buy this product

- Choice of four cover sizes in transparent or color versions
- Practical and easy-to-wire conductor connections
- High degree of flexibility due to the wide choice of versions
- Space-saving accommodation of electronic components in finely graded module versions available with 10 to 150 mm pitch
- User-friendly and safe mounting on DIN rails according to EN 60715
- Uniform and appropriate housing technology
- Inflammability class V0 insulation material (according to UL 94)
- Shock and contamination-proof accommodation of electronic components
- Universal PCBs for all pitches

### Key Commercial Data

Packing unit	2 STK
GTIN	 4 017918 131357

### Technical data

#### General

Housing type	Component housing
Housing material	Polycarbonate fiber reinforced
Color	green

#### Ambient conditions

Ambient temperature (operation)	-40 °C ... 125 °C
---------------------------------	-------------------

#### Dimensions

Length	75 mm
Constructional height	47.5 mm
Width	150 mm

#### Technical data

Flammability rating according to UL 94	V0
--	----

# Electronic housing - EMG150-LG/O - 2906571

## Technical data

### Technical data

Power dissipation without gap	12.3 W
Power dissipation with 20 mm gap	13.1 W

### Connection data

Conductor cross section solid min.	0.2 mm <sup>2</sup>
Conductor cross section solid max.	4 mm <sup>2</sup>
Conductor cross section flexible min.	0.2 mm <sup>2</sup>
Conductor cross section flexible max.	2.5 mm <sup>2</sup>
Conductor cross section AWG min.	24
Conductor cross section AWG max.	12

### Standards and Regulations

Flammability rating according to UL 94	V0
--	----

## Classifications

### eCl@ss

eCl@ss 4.0	27180401
eCl@ss 4.1	27180401
eCl@ss 5.0	27180506
eCl@ss 5.1	27180506
eCl@ss 6.0	27180802
eCl@ss 7.0	27182702
eCl@ss 8.0	27182702
eCl@ss 9.0	27182702

### ETIM

ETIM 2.0	EC001031
ETIM 3.0	EC001031
ETIM 4.0	EC001031
ETIM 5.0	EC001031

### UNSPSC

UNSPSC 6.01	31261501
UNSPSC 7.0901	31261501
UNSPSC 11	31261501
UNSPSC 12.01	31261501
UNSPSC 13.2	31261501

## Approvals

### Approvals

# Electronic housing - EMG150-LG/O - 2906571

## Approvals

Approvals

EAC

---

Ex Approvals

---

Approvals submitted

---

## Approval details

EAC

## Drawings

Dimensional drawing

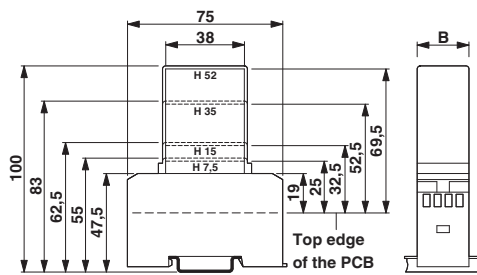

Dimensional drawing

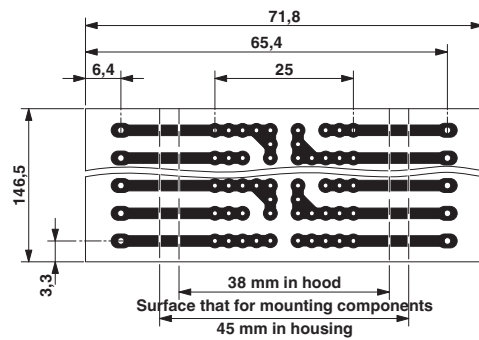

1 = Top edge of the PCB  
B = Housing width

## Electronic housing - EMG150-LG/O - 2906571

Dimensional drawing

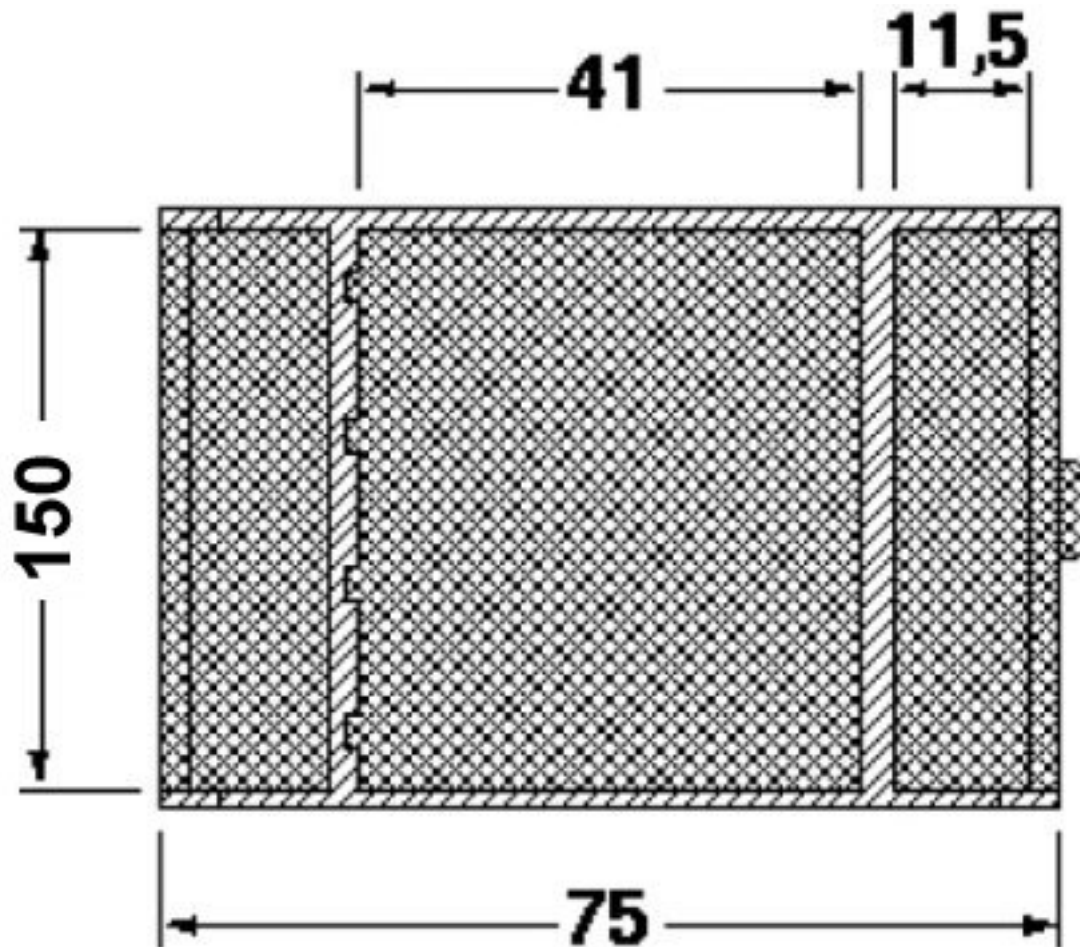

Phoenix Contact 2016 © - all rights reserved  
<http://www.phoenixcontact.com>

PHOENIX CONTACT GmbH & Co. KG  
Flachsmarktstr. 8  
32825 Blomberg  
Germany  
Tel. +49 5235 300  
Fax +49 5235 3 41200  
<http://www.phoenixcontact.com>



Below is a list of articles with direct links to our shop Electric Automation Network where you can see:

- Quote per purchase volume in real time.
- Online documentation and datasheets of all products.
- Estimated delivery time enquiry in real time.
- Logistics systems for the shipment of materials almost anywhere in the world.
- Purchasing management, order record and tracking of shipments.

To access the product, [click on the green button](#).

Product	Code	Reference	Product link
Electronic housing, for PCB insertion, without screw connection terminal blocks and cover, with open terminal space	2906571	EMG150-LG/O	<a href="#">Buy on EAN</a>