



Automatización Eléctrica
Especialistas en Automatización

At the end of this document you will find links to products related to this catalog. You can go directly to our shop by clicking [HERE](#). [HERE](#)

FO converters - FL MC EF WDM-SET SC - 2902660

Please be informed that the data shown in this PDF Document is generated from our Online Catalog. Please find the complete data in the user's documentation. Our General Terms of Use for Downloads are valid (<http://phoenixcontact.com/download>)



FO converter set, consisting of type A devices and type B devices, for full duplex transmission from 10/100Base-T(X) to individual simplex fiberglass with WDM (wavelength division multiplex) technology. SC simplex fiber optic connection (1550/1310 nm).

Why buy this product

- Device set for operation on one fiber
- Full duplex communication with only one fiber
- Transmission ranges up to 38 km
- Auto negotiation
- Auto MDI/MDI-X switch-over
- Link fault pass through (LFP) and far end fault (FEF) functions for easy connection monitoring
- Data rates 10/100 Mbps



Key Commercial Data

Packing unit	1 STK
GTIN	 4 046356 670616

Technical data

Ambient conditions

Altitude	5000 m (For restrictions see manufacturer's declaration)
	2000 m (With UL approval)

General

Net weight	434.2 g
------------	---------

Serial interface

Transmission medium	Copper
---------------------	--------

Optical interface FO

Wavelength	1550 nm
------------	---------

FO converters - FL MC EF WDM-SET SC - 2902660

Technical data

Optical interface FO

	1310 nm
Transmission length incl. 3 dB system reserve	38 km (With F-E 9/125 0.36 dB/km)
	34 km (With F-E 9/125 0.4 dB/km)
	28 km (With F-E 9/125 0.5 dB/km)
	21 km (with F-G 62,5/125 0,7 dB/km F 1000)
	5.5 km (with F-G 62.5/125 2.6 dB/km F 600)
	21 km (with F-G 50/125 0,7 dB/km F 1200)
	9 km (with F-G 50/125 1,6 dB/km F 800)
Transmission medium	Multi-mode fiberglass
	Single-mode fiberglass
Connection method	SC simplex

Articles in set

FO converters - FL MC EF WDM-A SC - 2902658



FO converter (replacement device A), for full duplex transmission from 10/100Base-T(X) to individual simplex fiberglass with WDM (wavelength division multiplex) technology, SC simplex fiber optic connection (1310/1550 nm). Device set (type A and type B) required for operation.

FO converters - FL MC EF WDM-B SC - 2902659



FO converter (replacement device B), for full duplex transmission from 10/100Base-T(X) to individual simplex fiberglass with WDM (wavelength division multiplex) technology, SC simplex fiber optic connection (1550/1310 nm). Device set (type A and type B) required for operation.

Classifications

eCl@ss

eCl@ss 4.0	27230207
eCl@ss 4.1	27230207
eCl@ss 5.0	27230207
eCl@ss 5.1	27230207
eCl@ss 6.0	27230207
eCl@ss 7.0	27230207
eCl@ss 8.0	19170114

FO converters - FL MC EF WDM-SET SC - 2902660

Classifications

ETIM

ETIM 3.0	EC000310
ETIM 4.0	EC000310
ETIM 5.0	EC001467

UNSPSC

UNSPSC 6.01	30211506
UNSPSC 7.0901	39121008
UNSPSC 11	39121008
UNSPSC 12.01	39121008
UNSPSC 13.2	39121008

Approvals

Approvals

Approvals

DNV / EAC / EAC

Ex Approvals

ATEX

Approvals submitted

Approval details

DNV

EAC

EAC

Drawings

FO converters - FL MC EF WDM-SET SC - 2902660

Dimensional drawing

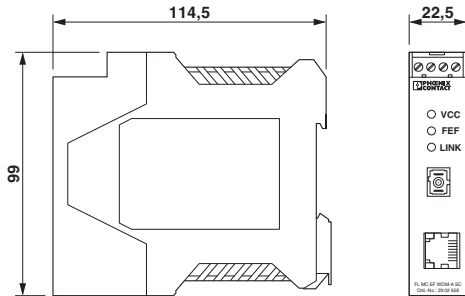

Schematic diagram

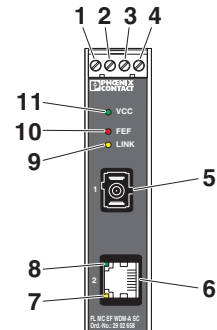

Front view

Schematic diagram

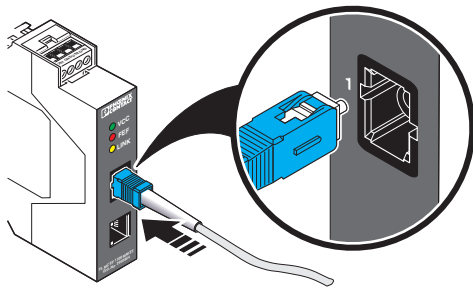

Connect SC simplex plug

Schematic diagram

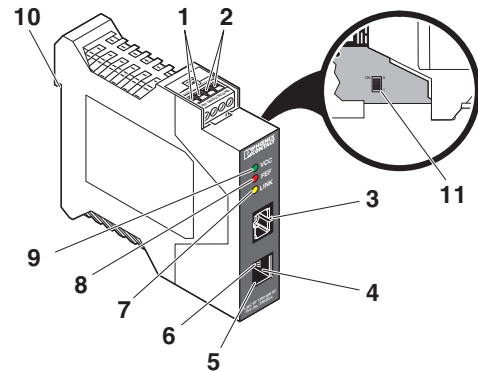

Function elements

Schematic diagram

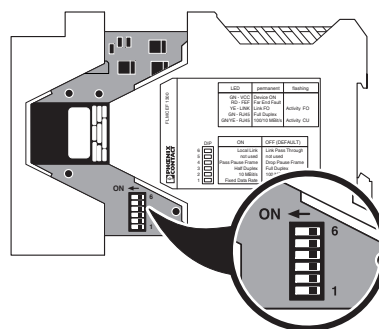

DIP switches

FO converters - FL MC EF WDM-SET SC - 2902660

Block diagram

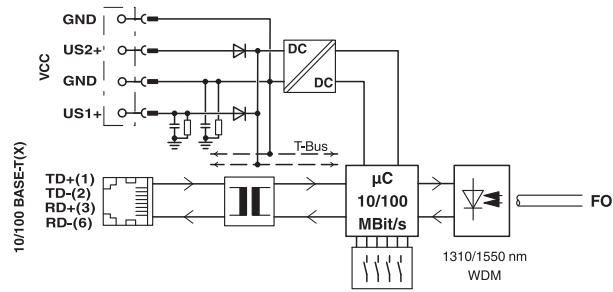

Phoenix Contact 2016 © - all rights reserved
<http://www.phoenixcontact.com>

PHOENIX CONTACT GmbH & Co. KG
Flachsmarktstr. 8
32825 Blomberg
Germany
Tel. +49 5235 300
Fax +49 5235 3 41200
<http://www.phoenixcontact.com>



Below is a list of articles with direct links to our shop Electric Automation Network where you can see:

- Quote per purchase volume in real time.
- Online documentation and datasheets of all products.
- Estimated delivery time enquiry in real time.
- Logistics systems for the shipment of materials almost anywhere in the world.
- Purchasing management, order record and tracking of shipments.

To access the product, [click on the green button.](#)

Product	Code	Reference	Product link
FO converter set, consisting of type A devices and type B devices, for full duplex transmission from 10/100Base-T(X) to individual simplex fiberglass with WDM (wavelength division multiplex) technology. SC simplex fiber optic connection (1550/1310 nm).	2902660	FL MC EF WDM-SET SC	Buy on EAN