



**Automatización Eléctrica**  
Especialistas en Automatización

At the end of this document you will find links to products related to this catalog. You can go directly to our shop by clicking HERE. [HERE](#)

# Hybrid motor starter - ELR H5-IES-SC- 24DC/500AC-2 - 2900414

Please be informed that the data shown in this PDF Document is generated from our Online Catalog. Please find the complete data in the user's documentation. Our General Terms of Use for Downloads are valid (<http://phoenixcontact.com/download>)



Hybrid motor starter for reversing 3~ AC motors up to 500 V AC and 2.4 A output current, with 24 V DC control voltage, adjustable overload shutdown and emergency stop function to SIL 3 / PL e and screw connection

## Why buy this product

- 22.5 mm wide
- Safety level according to IEC 61508-1: SIL 3, ISO 13849: PL e
- Reduction in wiring
- Long service life
- Space saving
- 3-phase loop bridges



## Key Commercial Data

Packing unit	1 STK
GTIN	 4 046356 504058

## Technical data

### Dimensions

Width	22.5 mm
Height	99 mm
Depth	114.5 mm

### Ambient conditions

Ambient temperature (operation)	-25 °C ... 70 °C (observe derating)
Ambient temperature (storage/transport)	-40 °C ... 80 °C
Degree of protection	IP20

### Device supply

Rated control circuit supply voltage $U_s$	24 V DC
Control supply voltage range	19.2 V DC ... 30 V DC
Rated control supply current $I_s$	40 mA

# Hybrid motor starter - ELR H5-IES-SC- 24DC/500AC-2 - 2900414

## Technical data

### Device supply

Protective circuit	Protection against polarity reversal Parallel polarity protection diode
	Surge protection

### Input data

Input name	Control input right/left
Rated actuating voltage $U_c$	24 V DC
Voltage range	19.2 V DC ... 30 V DC
Rated actuating current $I_c$	5 mA
Switching threshold	9.6 V ("0" signal)
	19.2 V ("1" signal)
Switching level	< 5 V DC (For EMERGENCY STOP)
Protective circuit	Protection against polarity reversal
Typical turn-off time	< 30 ms

### Output data load output

Output name	AC output
Rated operating voltage $U_e$	500 V AC
Operating voltage range	42 V AC ... 550 V AC
Load current range	180 mA ... 2.4 A (see to derating)
Trigger characteristic in acc. with IEC 60947	Class 10A
Cooling time	20 min. (for auto reset)
Rated operating current at AC-51	2.4 A
Rated operating current at AC-53a	2.4 A
Leakage current	0 mA
Protective circuit	Surge protection Varistor

### Output data reply output

Output name	Acknowledge output
Note	Confirmation: floating change-over contact, signal contact
Contact type	1 PDT
Switching capacity according to IEC 60947-5-1	3 A (230 V, AC15)
	2 A (24 V, DC13)

### General

Switching frequency	$\leq 2$ Hz (Load-dependent)
Mounting position	vertical (horizontal DIN rail, motor output below)
Assembly instructions	alignable, for spacing see derating
Operating mode	100% operating factor
Maximum power dissipation	4.1 W
Minimum power dissipation	0.88 W
Operating voltage display	Green LED
Status display	Yellow LED
Indication	Red LED

# Hybrid motor starter - ELR H5-IES-SC- 24DC/500AC-2 - 2900414

## Technical data

### Connection data, input side

Connection name	Control circuits
Connection method	Screw connection
Stripping length	8 mm
Screw thread	M3
Conductor cross section solid	0.2 mm <sup>2</sup> ... 2.5 mm <sup>2</sup>
Conductor cross section flexible	0.2 mm <sup>2</sup> ... 2.5 mm <sup>2</sup>
Conductor cross section AWG	24 ... 14
Torque	0.5 Nm ... 0.6 Nm

### Connection data, output side

Connection name	Load circuit
Connection method	Screw connection
Stripping length	8 mm
Screw thread	M3
Conductor cross section solid	0.2 mm <sup>2</sup> ... 2.5 mm <sup>2</sup>
Conductor cross section flexible	0.2 mm <sup>2</sup> ... 2.5 mm <sup>2</sup>
Conductor cross section AWG	24 ... 14
Torque	0.5 Nm ... 0.6 Nm

### Standards/regulations

Designation	Standards/regulations
Standards/regulations	IEC 60947-1
	EN 60947-4-2
	IEC 61508
	ISO 13849

### Insulation characteristics

Rated insulation voltage	500 V
Rated surge voltage	6 kV
Overvoltage category	III
Degree of pollution	2
Designation	Insulation characteristics between the control input and control supply voltage, and auxiliary circuit to the main circuit
Insulation	Safe isolation (IEC 60947-1) at operating voltage ≤ 300 V AC (e.g., 230/400 V AC, 277/480 V AC)
	Safe isolation (EN 50178) at operating voltage ≤ 300 V A (e.g., 230/400 V AC, 277/480 V AC)
	Basic isolation (IEC 60947-1) at operating voltage 300 ... 500 V AC
	Safe isolation (EN 50178) at operating voltage 300 ... 500 V AC
Designation	Isolation characteristics between the control input and control supply voltage to auxiliary circuit
Insulation	Safe isolation (IEC 60947-1) in the auxiliary circuit ≤ 300 V AC
	Safe isolation (EN 50178) in the auxiliary circuit ≤ 300 V AC

# Hybrid motor starter - ELR H5-IES-SC- 24DC/500AC-2 - 2900414

## Technical data

### Approvals/conformities

Safety Integrity Level according to IEC 61508	SIL 3 (safe shutdown)
	SIL 2 (motor protection)
Category acc. to EN ISO 13849	3 (Safe shutdown)
Performance level according to ISO 13849	e (Safe shutdown)
ATEX	# II (2) G [Ex e] [Ex d] [Ex px]
	# II (2) D [Ex t] [Ex p]
EU type-examination certificate	PTB 07 ATEX 3145

### UL data

SCCR	100 kA (480 V AC (fuse: 30 A class CC/30 A class J (high fault)))
	5 kA (480 V AC (fuse: 20 A RK5 (standard fault)))
FLA	2.4 A (480 V AC)
Group installation	20 A (class RK5, SCCR 5kA, #24 - 14 AWG max. solid and stranded)
	30 A (class CC or J, SCCR 100kA, #24 - 14 AWG max, solid and stranded)
Category code	NLDX / NRNT

### Standards and Regulations

Designation	Standards/regulations
Standards/regulations	IEC 60947-1
	EN 60947-4-2
	IEC 61508
	ISO 13849
ATEX	# II (2) G [Ex e] [Ex d] [Ex px]
	# II (2) D [Ex t] [Ex p]

## Classifications

### eCl@ss

eCl@ss 4.0	27371102
eCl@ss 4.1	27371102
eCl@ss 5.0	27371601
eCl@ss 5.1	27371601
eCl@ss 6.0	27371601
eCl@ss 7.0	27371601
eCl@ss 8.0	27370905

### ETIM

ETIM 2.0	EC000066
ETIM 3.0	EC000066
ETIM 4.0	EC000066
ETIM 5.0	EC002055

# Hybrid motor starter - ELR H5-IES-SC- 24DC/500AC-2 - 2900414

## Classifications

### UNSPSC

UNSPSC 6.01	30211915
UNSPSC 7.0901	39121514
UNSPSC 11	39121514
UNSPSC 12.01	39121514
UNSPSC 13.2	39121514

## Approvals

### Approvals

#### Approvals

UL Listed / cUL Listed / IECEE CB Scheme / GL / GL-SW / UL Listed / cUL Listed / EAC / EAC / cULus Listed / GL

#### Ex Approvals

ATEX

#### Approvals submitted

### Approval details

UL Listed

cUL Listed

IECEE CB Scheme

GL

GL-SW

UL Listed

# Hybrid motor starter - ELR H5-IES-SC- 24DC/500AC-2 - 2900414

## Approvals

cUL Listed

EAC

EAC

cULus Listed

GL

## Drawings

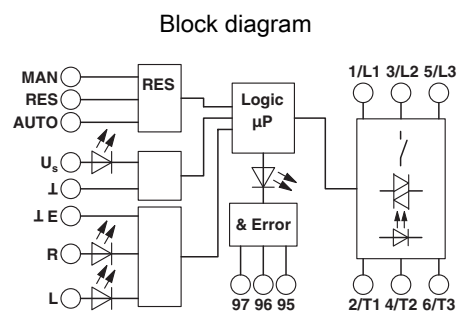
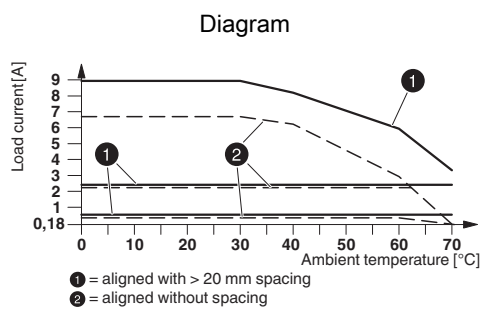

Derating diagram

# Hybrid motor starter - ELR H5-IES-SC- 24DC/500AC-2 - 2900414

Circuit diagram

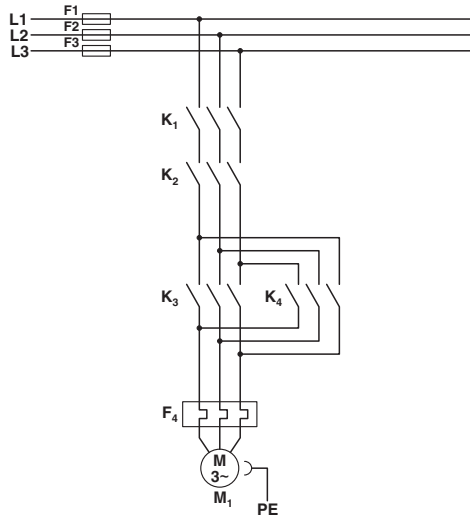

**Conventional structure**

Main current path for reversing contactor according to category 3

- K1 + K2 = Emergency stop contactor
- K3 = Left contactor
- K4 = Right contactor
- F4 = Motor protection relay

Circuit diagram

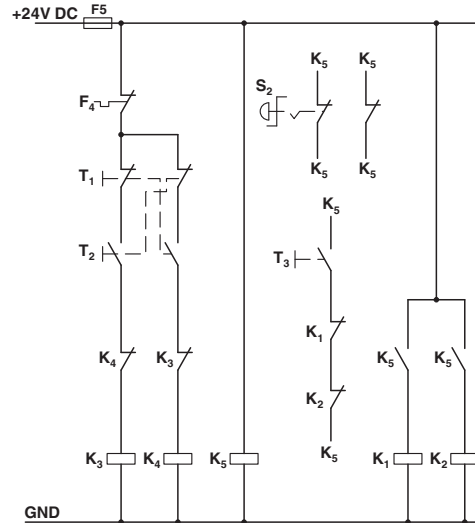

**Conventional structure**

Control current path reversing contactor according to category 3

- K1 + K2 = Emergency stop contactor
- K3 = Left contactor
- K4 = Right contactor
- K5 = PSR SCP-24DC.../Safety relay
- T1 = Right, T2 = Left, T3 = Reset
- S2 = Emergency stop
- F4 = Motor protection relay

Circuit diagram

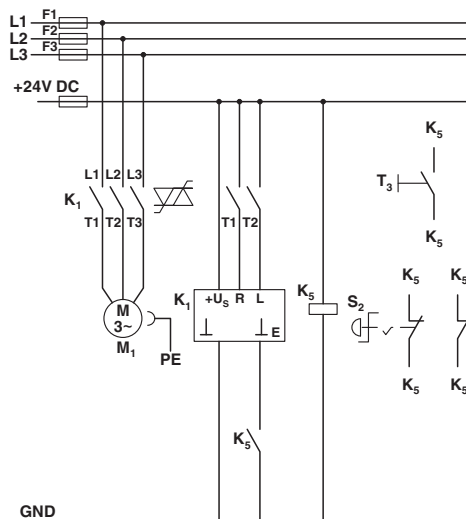

**Structure with CONTACTRON**

Main and control current path for '4 in 1' hybrid motor starter with reversing function according to category 3

K1 = '4 in 1' hybrid motor starter with reversing function



## Hybrid motor starter - ELR H5-IES-SC- 24DC/500AC-2 - 2900414

K5 = PSR SCP-24DC.../Safety relay

T1 = Right, T2 = Left, T3 = Reset

S2 = Emergency stop

---

Phoenix Contact 2016 © - all rights reserved

<http://www.phoenixcontact.com>

PHOENIX CONTACT GmbH & Co. KG

Flachsmarktstr. 8

32825 Blomberg

Germany

Tel. +49 5235 300

Fax +49 5235 3 41200

<http://www.phoenixcontact.com>

Below is a list of articles with direct links to our shop Electric Automation Network where you can see:

- Quote per purchase volume in real time.
- Online documentation and datasheets of all products.
- Estimated delivery time enquiry in real time.
- Logistics systems for the shipment of materials almost anywhere in the world.
- Purchasing management, order record and tracking of shipments.

To access the product, [click on the green button.](#)

<b>Product</b>	<b>Code</b>	<b>Reference</b>	<b>Product link</b>
Hybrid motor starter for reversing 3~ AC motors up to 500 V AC and 2.4 A output current, with 24 V DC control voltage, adjustable overload shutdown and emergency stop function to SIL 3 / PL e and screw connection	2900414	ELR H5-IES-SC-24DC/500AC-2	<a href="#">Buy on EAN</a>