



Automatización Eléctrica
Especialistas en Automatización

At the end of this document you will find links to products related to this catalog. You can go directly to our shop by clicking [HERE](#). [HERE](#)

Type 2 surge protection plug - VAL-US 480 ST - 2800743

Please be informed that the data shown in this PDF Document is generated from our Online Catalog. Please find the complete data in the user's documentation. Our General Terms of Use for Downloads are valid (<http://phoenixcontact.com/download>)



Surge protection connector type 2 with high-capacity varistor for VAL-MS base element, thermal monitoring, visual fault warning. Design: 480 V AC

The figure shows the VAL-US 347 ST version

Key Commercial Data

Packing unit	10 STK
GTIN	 4 046356 641951

Technical data

Dimensions

Height	52.4 mm
Width	17.5 mm
Depth	55.3 mm
Horizontal pitch	1 Div.

Ambient conditions

Degree of protection	IP20
Ambient temperature (operation)	-40 °C ... 80 °C
Ambient temperature (storage/transport)	-40 °C ... 80 °C
Altitude	≤ 2000 m (amsl (above mean sea level))
Permissible humidity (operation)	5 % ... 95 %
Shock (operation)	25g
Vibration (operation)	5g

General

Standards/specifications	IEC 61643-11 2011
	EN 61643-11 2012
IEC test classification	II
	T2
EN type	T2
SPD design	Voltage-limiting type
Mode of protection	L-PEN

Type 2 surge protection plug - VAL-US 480 ST - 2800743

Technical data

General

	L-PE
Mounting type	On base element
Color	black
Housing material	PA 6.6
Degree of pollution	2
Distance between live and grounded parts	5 mm
Flammability rating according to UL 94	V-0
Type	Male
Number of positions	1
Surge protection fault message	optical

Additional descriptions

Note	Usable in all low-voltage systems between L-N or L-PEN. Only usable in IT Systems between L-PE, if the exposed-conductive-parts (bodies) of the equipment of the low-voltage installation is connected to the earthing arrangement of the transformer substation. (interconnected earthing arrangement of the HV-transformer substation with the bodies of the LV-installation. $R_E = R_A$ accordance to IEC 60364-4-442 / VDE 0100-442 Fig. 44D / Example a)
------	---

Protective circuit

Nominal voltage U_N	400/690 V AC (TN)
	500 V AC (IT)
Nominal frequency f_N	60 Hz (50 Hz)
Maximum continuous voltage U_C	580 V AC
Residual current I_{PE}	≤ 0.25 mA
Standby power consumption P_C	≤ 150 mVA
Nominal discharge current I_n (8/20) μ s	15 kA
Maximum discharge current I_{max} (8/20) μ s	30 kA
Short-circuit current rating I_{SCCR}	25 kA
Voltage protection level U_p	≤ 2.5 kV
Residual voltage U_{res}	≤ 2.5 kV (at I_n)
	≤ 2.3 kV (at 10 kA)
	≤ 2.1 kV (at 5 kA)
	≤ 1.9 kV (at 3 kA)
TOV behavior at U_T	690 V AC (5 s / withstand mode)
Response time t_A	≤ 25 ns
Max. backup fuse with branch wiring	125 A (gG)

Connection data

Connection method	VALVETRAB plug-in system
-------------------	--------------------------

UL specifications

SPD Type	4 (for Type 2 applications)
----------	-----------------------------

Type 2 surge protection plug - VAL-US 480 ST - 2800743

Technical data

UL specifications

Maximum continuous operating voltage MCOV (L-N)	580 V AC
Nom. voltage	480 V AC
Mode of protection	L-N
Power distribution system	1
Nominal frequency	50/60 Hz
Voltage protection rating VPR (L-N)	1.8 kV
Nominal discharge current I _n (L-N)	10 kA

Classifications

eCl@ss

eCl@ss 4.0	27140201
eCl@ss 4.1	27130801
eCl@ss 5.0	27130801
eCl@ss 5.1	27130801
eCl@ss 6.0	27130803
eCl@ss 7.0	27130803
eCl@ss 8.0	27130805

ETIM

ETIM 3.0	EC000472
ETIM 4.0	EC000472
ETIM 5.0	EC000941

UNSPSC

UNSPSC 6.01	30212010
UNSPSC 7.0901	39121610
UNSPSC 11	39121610
UNSPSC 12.01	39121610
UNSPSC 13.2	39121620

Approvals

Approvals

Approvals

UL Recognized / cUL Recognized / EAC / cULus Recognized

Ex Approvals

Type 2 surge protection plug - VAL-US 480 ST - 2800743

Approvals

Approvals submitted

Approval details

UL Recognized

cUL Recognized

EAC

cULus Recognized

Drawings

Dimensional drawing

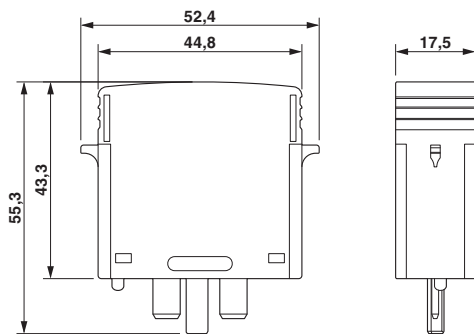

Circuit diagram



Phoenix Contact 2016 © - all rights reserved
<http://www.phoenixcontact.com>

PHOENIX CONTACT GmbH & Co. KG
Flachsmarktstr. 8
32825 Blomberg
Germany
Tel. +49 5235 300
Fax +49 5235 3 41200
<http://www.phoenixcontact.com>



Automatización Eléctrica
Especialistas en Automatización

Below is a list of articles with direct links to our shop Electric Automation Network where you can see:

- Quote per purchase volume in real time.
- Online documentation and datasheets of all products.
- Estimated delivery time enquiry in real time.
- Logistics systems for the shipment of materials almost anywhere in the world.
- Purchasing management, order record and tracking of shipments.

To access the product, [click on the green button.](#)

Product	Code	Reference	Product link
Surge protection connector type 2 with high-capacity varistor for VAL-MS base element, thermal monitoring, visual fault warning. Design: 480 V AC	2800743	VAL-US 480 ST	Buy on EAN