



Automatización Eléctrica
Especialistas en Automatización

At the end of this document you will find links to products related to this catalog. You can go directly to our shop by clicking [HERE](#). [HERE](#)

Electronic housing - UEG 30/1 - 2790871

Please be informed that the data shown in this PDF Document is generated from our Online Catalog. Please find the complete data in the user's documentation. Our General Terms of Use for Downloads are valid (<http://phoenixcontact.com/download>)



Electronic housing, for PCB insertion, fully equipped with 4 screw or tab connections per side

Why buy this product

- Universal P1-UEG... PCBs are available for laboratory samples and small series
- Cost-effective series production, since the base element and the assembled PCB are soldered by machine
- Efficient assembly thanks to overlapping housing parts
- Can be snapped onto standard NS 35/7,5 and NS 35/15 DIN rails
- Up to 16 connections on two levels
- Installation of one or two PCBs in the housing

Key Commercial Data

Packing unit	10 STK
Minimum order quantity	10 STK
GTIN	 4 017918 072360

Technical data

General

Housing type	Complete housing
Housing material	Polyamide (PA 6.6)
Color	green

Ambient conditions

Ambient temperature (operation)	-40 °C ... 105 °C
---------------------------------	-------------------

Dimensions

Length	79.5 mm
Constructional height	70 mm
Width	30 mm
Pitch	5 mm

Technical data

Flammability rating according to UL 94	V0
--	----

Electronic housing - UEG 30/1 - 2790871

Technical data

Technical data

Power dissipation without gap	4 W
Power dissipation with 20 mm gap	7.2 W
Number of positions	8

Connection data

Conductor cross section solid min.	0.2 mm ²
Conductor cross section solid max.	4 mm ²
Conductor cross section flexible min.	0.2 mm ²
Conductor cross section flexible max.	2.5 mm ²
Conductor cross section AWG min.	24
Conductor cross section AWG max.	12
Stripping length	8 mm

Standards and Regulations

Flammability rating according to UL 94	V0
--	----

Classifications

eCl@ss

eCl@ss 4.0	27180401
eCl@ss 4.1	27180401
eCl@ss 5.0	27180506
eCl@ss 5.1	27180506
eCl@ss 6.0	27180802
eCl@ss 7.0	27182702
eCl@ss 8.0	27182702
eCl@ss 9.0	27182702

ETIM

ETIM 2.0	EC001031
ETIM 3.0	EC001031
ETIM 4.0	EC001031
ETIM 5.0	EC001031

UNSPSC

UNSPSC 6.01	31261501
UNSPSC 7.0901	31261501
UNSPSC 11	31261501
UNSPSC 12.01	31261501
UNSPSC 13.2	31261501

Electronic housing - UEG 30/1 - 2790871

Approvals

Approvals

Approvals

UL Recognized / EAC / cULus Recognized

Ex Approvals

Approvals submitted

Approval details

UL Recognized

EAC

cULus Recognized		
	B	D
mm ² /AWG/kcmil	30-12	30-12
Nominal current I _N	10 A	10 A
Nominal voltage U _N	300 V	300 V

Drawings

Explosion drawing

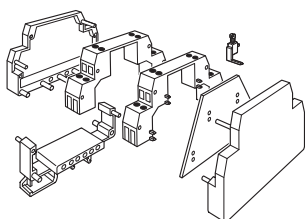

Dimensional drawing

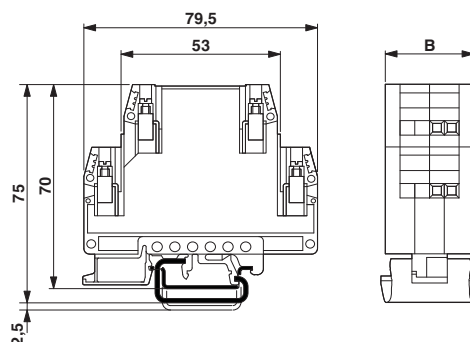

Electronic housing - UEG 30/1 - 2790871

Dimensional drawing

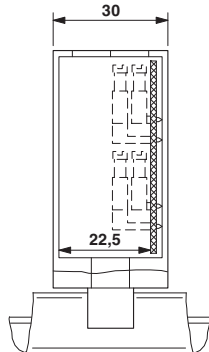

Dimensional drawing

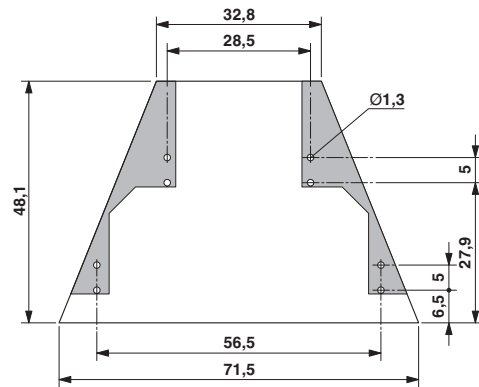

UEG 30/1, enlarged internal area, with 1 PCB, up to max. 8 positions

Schematic diagram

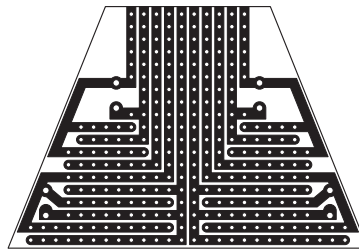

Phoenix Contact 2016 © - all rights reserved
<http://www.phoenixcontact.com>

PHOENIX CONTACT GmbH & Co. KG
Flachsmarktstr. 8
32825 Blomberg
Germany
Tel. +49 5235 300
Fax +49 5235 3 41200
<http://www.phoenixcontact.com>



Below is a list of articles with direct links to our shop Electric Automation Network where you can see:

- Quote per purchase volume in real time.
- Online documentation and datasheets of all products.
- Estimated delivery time enquiry in real time.
- Logistics systems for the shipment of materials almost anywhere in the world.
- Purchasing management, order record and tracking of shipments.

To access the product, [click on the green button.](#)

Product	Code	Reference	Product link
Electronic housing, for PCB insertion, fully equipped with 4 screw or tab connections per side	2790871	UEG 30/1	Buy on EAN