



Automatización Eléctrica
Especialistas en Automatización

At the end of this document you will find links to products related to this catalog. You can go directly to our shop by clicking [HERE](#). [HERE](#)

Electronic housing - UEGH 25 - 2757115

Please be informed that the data shown in this PDF Document is generated from our Online Catalog. Please find the complete data in the user's documentation. Our General Terms of Use for Downloads are valid (<http://phoenixcontact.com/download>)



Electronic housing, double-level, fully equipped with 6 screw connections per side for one printed circuit board

The illustration shows version UEGH 22,5

Why buy this product

- Efficient assembly thanks to overlapping housing parts
- Can accommodate up to two PCBs
- Can be snapped onto standard NS 35/7,5 and NS 35/15 DIN rails
- Increased number of positions thanks to optional UEGM-MT FS slip-on connections

Key Commercial Data

Packing unit	10 STK
GTIN	 4 017918 108021

Technical data

General

Housing type	Complete housing
Housing material	Polyamide (PA 6.6)
Color	green

Ambient conditions

Ambient temperature (operation)	-40 °C ... 105 °C
---------------------------------	-------------------

Dimensions

Length	79 mm
Constructional height	106.7 mm
Width	25 mm
Pitch	5 mm

Technical data

Connection in acc. with standard	CUL
Nominal voltage U_N	300 V
Nominal current I_N	10 A

Electronic housing - UEGH 25 - 2757115

Technical data

Technical data

AWG/kcmil	30-12
Indicator1	CUL1
Flammability rating according to UL 94	V0
Power dissipation without gap	4.8 W
Power dissipation with 20 mm gap	7.2 W
Number of positions	12

Connection data

Conductor cross section solid min.	0.2 mm ²
Conductor cross section solid max.	4 mm ²
Conductor cross section flexible min.	0.2 mm ²
Conductor cross section flexible max.	2.5 mm ²
Conductor cross section AWG min.	24
Conductor cross section AWG max.	12
Stripping length	8 mm

Standards and Regulations

Connection in acc. with standard	CUL
Flammability rating according to UL 94	V0

Classifications

eCl@ss

eCl@ss 4.0	27180401
eCl@ss 4.1	27180401
eCl@ss 5.0	27180506
eCl@ss 5.1	27180506
eCl@ss 6.0	27180802
eCl@ss 7.0	27182702
eCl@ss 8.0	27182702
eCl@ss 9.0	27182702

ETIM

ETIM 2.0	EC001031
ETIM 3.0	EC001031
ETIM 4.0	EC001031
ETIM 5.0	EC001031

UNSPSC

UNSPSC 6.01	31261501
UNSPSC 7.0901	31261501
UNSPSC 11	31261501

Electronic housing - UEGH 25 - 2757115

Classifications

UNSPSC

UNSPSC 12.01	31261501
UNSPSC 13.2	31261501

Approvals

Approvals

Approvals

UL Recognized / cUL Recognized / EAC / UL Recognized / cULus Recognized

Ex Approvals

Approvals submitted

Approval details

UL Recognized

cUL Recognized		
	B	D
mm ² /AWG/kcmil	30-12	30-12
Nominal current I _N	10 A	10 A
Nominal voltage U _N	300 V	300 V

EAC

UL Recognized		
	B	D
mm ² /AWG/kcmil	30-12	30-12
Nominal current I _N	10 A	10 A
Nominal voltage U _N	300 V	300 V

cULus Recognized

Electronic housing - UEGH 25 - 2757115

Drawings

Dimensional drawing

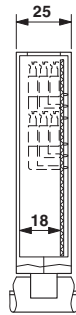

Dimensional drawing

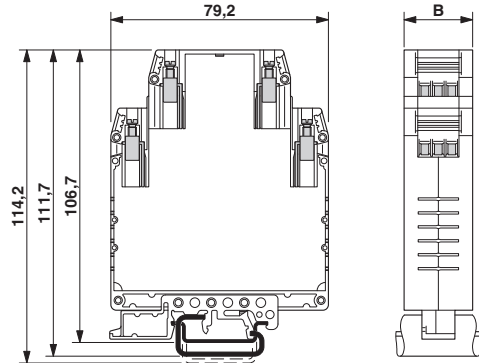

For 1 PCB, 12 pos.

Dimensional drawing

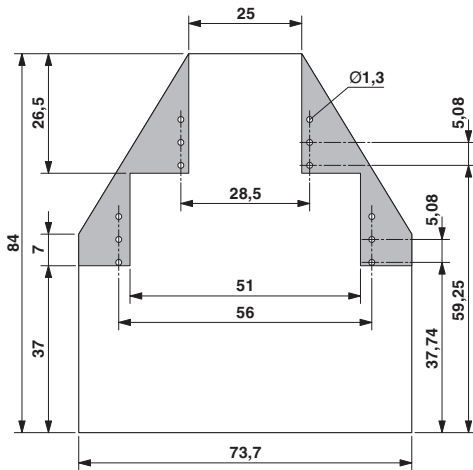

Schematic diagram

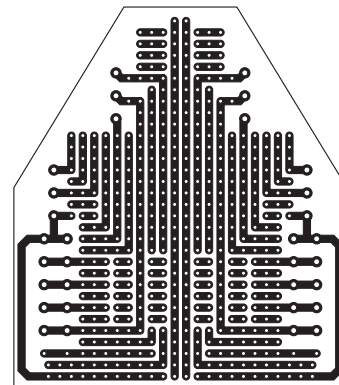

Phoenix Contact 2016 © - all rights reserved
<http://www.phoenixcontact.com>

PHOENIX CONTACT GmbH & Co. KG
Flachsmarktstr. 8
32825 Blomberg
Germany
Tel. +49 5235 300
Fax +49 5235 3 41200
<http://www.phoenixcontact.com>



Below is a list of articles with direct links to our shop Electric Automation Network where you can see:

- Quote per purchase volume in real time.
- Online documentation and datasheets of all products.
- Estimated delivery time enquiry in real time.
- Logistics systems for the shipment of materials almost anywhere in the world.
- Purchasing management, order record and tracking of shipments.

To access the product, [click on the green button.](#)

Product	Code	Reference	Product link
Electronic housing, double-level, fully equipped with 6 screw connections per side for one printed circuit board	2757115	UEGH 25	Buy on EAN