



Automatización Eléctrica
Especialistas en Automatización

At the end of this document you will find links to products related to this catalog. You can go directly to our shop by clicking [HERE](#). [HERE](#)

Housing - UEGM 27,5-SMD - 2757063

Please be informed that the data shown in this PDF Document is generated from our Online Catalog. Please find the complete data in the user's documentation. Our General Terms of Use for Downloads are valid (<http://phoenixcontact.com/download>)



Electronic housing, for PCB insertion, fully equipped with 3 screw connections per side, for mounting of SMD components

Illustration shows version UEGM 22.5

Why buy this product

- Cost-effective series production, since the base element and the assembled PCB are soldered by machine
- Efficient assembly thanks to overlapping housing parts
- Can be snapped onto standard NS 35/7,5 and NS 35/15 DIN rails
- Complex electronic circuits can be integrated, with up to 24 connections on two levels

Key Commercial Data

Packing unit	10 STK
GTIN	 4 017918 139537

Technical data

General

Housing type	Complete housing
Housing material	Polyamide (PA 6.6)
Color	green

Ambient conditions

Ambient temperature (operation)	-40 °C ... 105 °C
---------------------------------	-------------------

Dimensions

Length	79 mm
Constructional height	85.5 mm
Width	27.5 mm
Pitch	5 mm

Technical data

Flammability rating according to UL 94	V0
Number of positions	6

Connection data

Housing - UEGM 27,5-SMD - 2757063

Technical data

Connection data

Conductor cross section solid min.	0.2 mm ²
Conductor cross section solid max.	4 mm ²
Conductor cross section flexible min.	0.2 mm ²
Conductor cross section flexible max.	2.5 mm ²
Conductor cross section AWG min.	24
Conductor cross section AWG max.	12
Stripping length	8 mm

Standards and Regulations

Flammability rating according to UL 94	V0
--	----

Classifications

eCl@ss

eCl@ss 4.0	27180401
eCl@ss 4.1	27180401
eCl@ss 5.0	27180506
eCl@ss 5.1	27180506
eCl@ss 6.0	27180802
eCl@ss 7.0	27182702
eCl@ss 8.0	27182702
eCl@ss 9.0	27182702

ETIM

ETIM 2.0	EC001031
ETIM 3.0	EC001031
ETIM 4.0	EC001031
ETIM 5.0	EC001031

UNSPSC

UNSPSC 6.01	31261501
UNSPSC 7.0901	31261501
UNSPSC 11	31261501
UNSPSC 12.01	31261501
UNSPSC 13.2	31261501

Approvals

Approvals

Approvals

UL Recognized / EAC

Housing - UEGM 27,5-SMD - 2757063

Approvals

Ex Approvals

Approvals submitted

Approval details

UL Recognized

EAC

Drawings

Explosion drawing

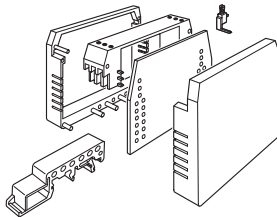

Dimensional drawing

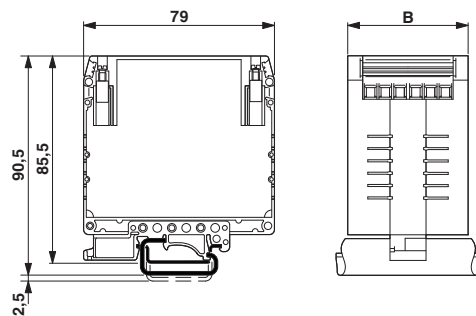

Dimensional drawing

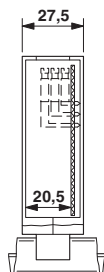

Dimensional drawing

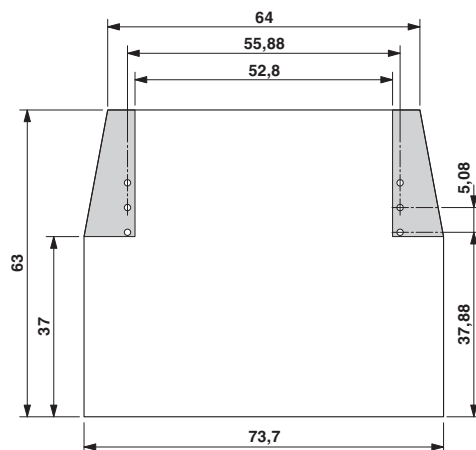

UEGM 25... und UEGM 27,5-SMD with 1 PCB, 6 positions or 12 positions (FS/FS)

Housing - UEGM 27,5-SMD - 2757063

Schematic diagram

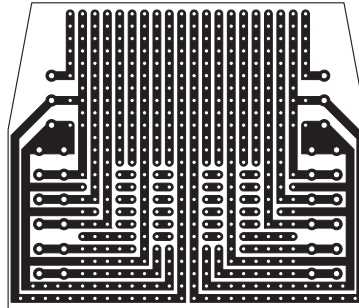

Phoenix Contact 2016 © - all rights reserved
<http://www.phoenixcontact.com>

PHOENIX CONTACT GmbH & Co. KG
Flachmarktstr. 8
32825 Blomberg
Germany
Tel. +49 5235 300
Fax +49 5235 3 41200
<http://www.phoenixcontact.com>



Below is a list of articles with direct links to our shop Electric Automation Network where you can see:

- Quote per purchase volume in real time.
- Online documentation and datasheets of all products.
- Estimated delivery time enquiry in real time.
- Logistics systems for the shipment of materials almost anywhere in the world.
- Purchasing management, order record and tracking of shipments.

To access the product, [click on the green button.](#)

Product	Code	Reference	Product link
Electronic housing, for PCB insertion, fully equipped with 3 screw connections per side, for mounting of SMD components	2757063	UEGM 27,5-SMD	Buy on EAN