



**Automatización Eléctrica**  
Especialistas en Automatización

At the end of this document you will find links to products related to this catalog. You can go directly to our shop by clicking [HERE](#). [HERE](#)

## Distributed I/O device - FLM DI 8 M12 - 2736288

Please be informed that the data shown in this PDF Document is generated from our Online Catalog. Please find the complete data in the user's documentation. Our General Terms of Use for Downloads are valid (<http://phoenixcontact.com/download>)



The local bus device has digital inputs. Functions: 8 digital inputs, 3 ms filter time, 500 kbaud/2 Mbaud selection, channel-specific diagnostics, short-circuit and overload protection, 600 mA nominal current, M12 fast connection technology.

### Why buy this product

- Flexible power supply concept
- SPEEDCON fast locking system
- Short-circuit and overload protection
- Diagnostic and status indicators
- Consistent connection via M12 connectors

### Key Commercial Data

Packing unit	1 STK
GTIN	 4 017918 951054

### Technical data

#### Note

Utilization restriction	EMC: class A product, see manufacturer's declaration in the download area
-------------------------	---

#### Dimensions

Width	70 mm
Height	178.5 mm
Depth	50 mm
Drill hole spacing	168 mm

#### Ambient conditions

Ambient temperature (operation)	-25 °C ... 60 °C
Ambient temperature (storage/transport)	-25 °C ... 85 °C
Permissible humidity (storage/transport)	95 %
Air pressure (operation)	80 kPa ... 106 kPa (up to 2000 m above sea level)
Air pressure (storage/transport)	70 kPa ... 106 kPa (up to 3000 m above sea level)
Degree of protection	IP65/IP67

#### General

# Distributed I/O device - FLM DI 8 M12 - 2736288

## Technical data

### General

Net weight	290 g
Mounting type	Wall mounting

### Interfaces

Designation	Fieldline local bus
Connection method	M12 connector, B-coded
Designation connection point	Copper cable
Transmission speed	500 kBit/s / 2 MBit/s
Number of positions	5

### Power supply for module electronics

Connection method	M12 connector
Designation	$U_L$
Supply voltage	24 V DC
Supply voltage range	18 V DC ... 30 V DC (including ripple)

### Fieldline potentials

Voltage supply $U_L$	24 V DC
Power supply at $U_L$	max. 4 A
Current consumption from $U_L$	max. 50 mA (At 2 Mbaud)
	typ. 40 mA (At 2 Mbaud)
	max. 50 mA (At 500 kBaud)
	typ. 35 mA (At 500 kBaud)
Voltage supply $U_S$	24 V DC
Power supply at $U_S$	max. 4 A
Current consumption from $U_S$	typ. 5 mA (plus power supply for sensors)
	max. 600 mA

### Digital inputs

Input name	Digital inputs
Connection method	M12 connector
	2, 3, 4-wire
Number of inputs	8
Protective circuit	Protection against polarity reversal
Filter time	3 ms
Input characteristic curve	IEC 61131-2 type 1
Input voltage	24 V DC
Input voltage range "0" signal	-30 V DC ... 5 V DC
Input voltage range "1" signal	13 V DC ... 30 V DC
Delay at signal change from 0 to 1	3.1 ms
Delay at signal change from 1 to 0	4.1 ms

### Standards and Regulations

# Distributed I/O device - FLM DI 8 M12 - 2736288

## Technical data

### Standards and Regulations

Test section	To I/O 500 V AC
Mechanical tests	Shock in acc. with EN 60068-2-27/IEC 60068-2-27 Load 30g, half sine wave, positive and negative per direction
	Vibration resistance in acc. with EN 60068-2-6/IEC 60068-2-6 5g in each space direction
Connection in acc. with standard	CUL
Protection class	III, IEC 61140, EN 61140, VDE 0140-1

## Classifications

### eCl@ss

eCl@ss 4.0	27250302
eCl@ss 4.1	27250302
eCl@ss 5.0	27250302
eCl@ss 5.1	27242604
eCl@ss 6.0	27242604
eCl@ss 7.0	27242604
eCl@ss 8.0	27242604
eCl@ss 9.0	27242604

### ETIM

ETIM 2.0	EC001430
ETIM 3.0	EC001599
ETIM 4.0	EC001599
ETIM 5.0	EC001599

### UNSPSC

UNSPSC 6.01	43172015
UNSPSC 7.0901	43201404
UNSPSC 11	43172015
UNSPSC 12.01	43201404
UNSPSC 13.2	43201404

## Approvals

### Approvals

#### Approvals

UL Recognized / cUL Recognized / EAC / cULus Recognized

# Distributed I/O device - FLM DI 8 M12 - 2736288

## Approvals

Ex Approvals

UL Recognized / cUL Recognized / cULus Recognized

Approvals submitted

## Approval details

UL Recognized

cUL Recognized

EAC

cULus Recognized

## Drawings

Dimensional drawing

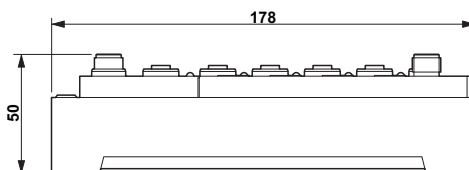

## Distributed I/O device - FLM DI 8 M12 - 2736288

Connection diagram

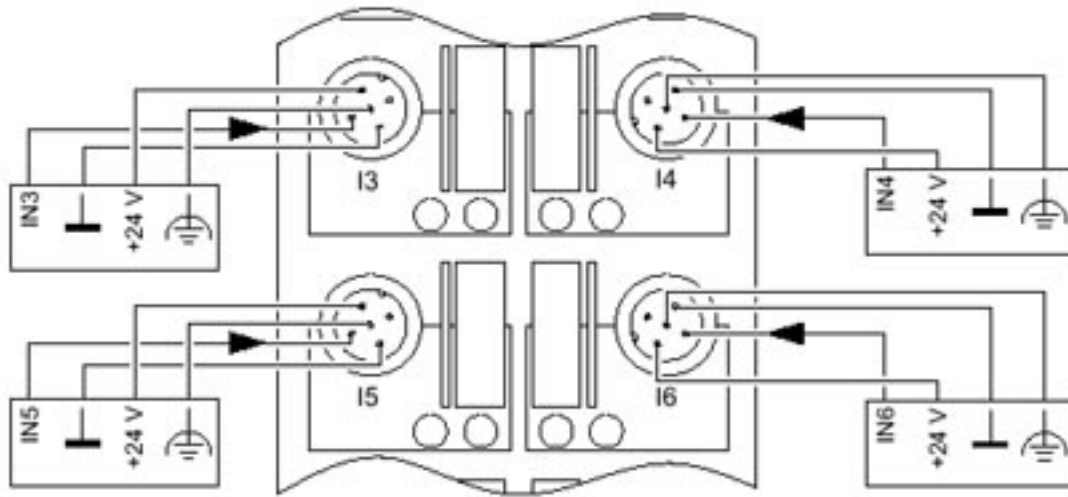

Phoenix Contact 2016 © - all rights reserved  
<http://www.phoenixcontact.com>

PHOENIX CONTACT GmbH & Co. KG  
Flachsmarktstr. 8  
32825 Blomberg  
Germany  
Tel. +49 5235 300  
Fax +49 5235 3 41200  
<http://www.phoenixcontact.com>

Below is a list of articles with direct links to our shop Electric Automation Network where you can see:

- Quote per purchase volume in real time.
- Online documentation and datasheets of all products.
- Estimated delivery time enquiry in real time.
- Logistics systems for the shipment of materials almost anywhere in the world.
- Purchasing management, order record and tracking of shipments.

To access the product, [click on the green button](#).

<b>Product</b>	<b>Code</b>	<b>Reference</b>	<b>Product link</b>
The local bus device has digital inputs. Functions: 8 digital inputs, 3 ms filter time, 500 kbaud/2 Mbaud selection, channel-specific diagnostics, short-circuit and overload protection, 600 mA nominal current, M12 fast connection technology.	2736288	FLM DI 8 M12	<a href="#">Buy on EAN</a>