



**Automatización Eléctrica**  
Especialistas en Automatización

At the end of this document you will find links to products related to this catalog. You can go directly to our shop by clicking [HERE](#). [HERE](#)

## Bus system connector - SACC-M12MS-5SC SH DN - 1549793

Please be informed that the data shown in this PDF Document is generated from our Online Catalog. Please find the complete data in the user's documentation. Our General Terms of Use for Downloads are valid (<http://phoenixcontact.com/download>)



Bus system connector, 5-position, shielded, Plug straight M12, A-coded, Spring-cage connection, Knurl material: Nickel-plated brass, External cable diameter 4 mm ... 8 mm

### Why buy this product

- Safe use in the field, thanks to a high degree of protection
- Flexible: connectors for on-site assembly
- Spring-cage connection: connect more securely, even in the case of shock and vibration, thanks to high contact forces
- Reliable signal transmission - 360° shielding in environments with electromagnetic interference



### Key Commercial Data

Packing unit	1 STK
GTIN	 4 046356 149013

### Technical data

#### Dimensions

Wrench size, union nut	13 mm
External diameter	4 mm ... 8 mm
Stripping length of the sheath	33 mm
Stripping length of the individual wire	10 mm

#### Ambient conditions

Ambient temperature (operation)	-40 °C ... 85 °C (Plug / socket)
Degree of protection	IP67

#### General

Rated current at 40°C	4 A
Rated voltage	60 V DC
	48 V AC
Number of positions	5
Insulation resistance	≥ 100 MΩ
Coding	A - standard

# Bus system connector - SACC-M12MS-5SC SH DN - 1549793

## Technical data

### General

Standards/regulations	M12 connector IEC 61076-2-101
Status display	No
Overvoltage category	II
Degree of pollution	3
Connection method	Spring-cage connection
Conductor cross section	0.14 mm <sup>2</sup> ... 0.5 mm <sup>2</sup>
Conductor cross section AWG	26 ... 20
Insertion/withdrawal cycles	≥ 100
Torque	0.4 Nm (M12 knurl)
	0.8 Nm (Connector with coupling sleeve)
	3 Nm (Pressure nut)
Assembly instructions	The wires can be connected both with ferrules and without ferrules

### Material

Flammability rating according to UL 94	V0
Contact material	CuSn
Contact surface material	Ni/Au
Contact carrier material	PA 66
Material of grip body	Zinc die-cast, nickel-plated
Material, knurls	Nickel-plated brass
Sealing material	NBR

### Standards and Regulations

Standard designation	M12 connector
Standards/regulations	IEC 61076-2-101
Connection in acc. with standard	CUL
Flammability rating according to UL 94	V0

## Classifications

### eCl@ss

eCl@ss 4.0	27250313
eCl@ss 4.1	27250313
eCl@ss 5.0	27143423
eCl@ss 5.1	27143423
eCl@ss 6.0	27143423
eCl@ss 7.0	27449001
eCl@ss 8.0	27440104
eCl@ss 9.0	27440102

### ETIM

ETIM 3.0	EC002062
----------	----------

# Bus system connector - SACC-M12MS-5SC SH DN - 1549793

## Classifications

### ETIM

ETIM 4.0	EC002062
ETIM 5.0	EC002062

### UNSPSC

UNSPSC 6.01	31251501
UNSPSC 7.0901	31251501
UNSPSC 11	31251501
UNSPSC 12.01	31251501
UNSPSC 13.2	31251501

## Approvals

### Approvals

---

#### Approvals

UL Recognized / cUL Recognized / cULus Recognized

---

#### Ex Approvals

---

#### Approvals submitted

---

## Approval details

UL Recognized 	
Nominal current IN	4 A
Nominal voltage UN	125 V

cUL Recognized 	
Nominal current IN	4 A
Nominal voltage UN	125 V

# Bus system connector - SACC-M12MS-5SC SH DN - 1549793

## Approvals

cULus Recognized us

## Drawings

Schematic diagram

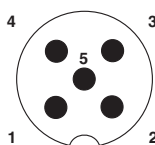

Pin assignment M12 male connector, 5-pos., A-coded, male side

Functional drawing

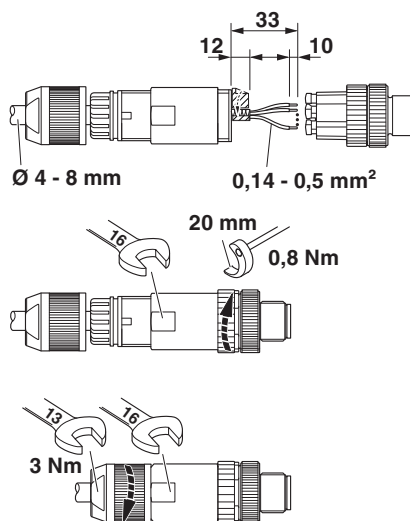

Slide the pressure nut and sleeve housing along the cable, strip the cable, shorten the shield, strip the single wires, connect the wires, in the case of a straight sleeve housing gently twist the wires together, stick the shielding foil around the shortened shield, in the case of a cable outside diameter < 6 mm stick an additional shielding foil around the wire pack, screw the sleeve housing to the plug insert, screw the pressure nut tight.

Dimensional drawing

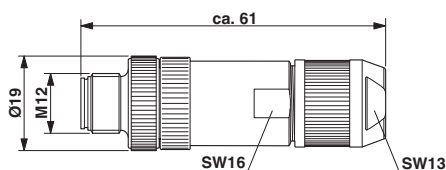

Plug, M12 x 1, straight, shielded

Phoenix Contact 2016 © - all rights reserved  
<http://www.phoenixcontact.com>

PHOENIX CONTACT GmbH & Co. KG  
Flachsmarktstr. 8  
32825 Blomberg  
Germany  
Tel. +49 5235 300  
Fax +49 5235 3 41200  
<http://www.phoenixcontact.com>



Below is a list of articles with direct links to our shop Electric Automation Network where you can see:

- Quote per purchase volume in real time.
- Online documentation and datasheets of all products.
- Estimated delivery time enquiry in real time.
- Logistics systems for the shipment of materials almost anywhere in the world.
- Purchasing management, order record and tracking of shipments.

To access the product, [click on the green button](#).

Product	Code	Reference	Product link
Bus system connector, 5-position, shielded, Plug straight M12, A-coded, Spring-cage connection, Knurl material: Nickel-plated brass, External cable diameter 4 mm ... 8 mm	1549793	SACC-M12MS-5SC SH DN	<a href="#">Buy on EAN</a>