



Automatización Eléctrica
Especialistas en Automatización

At the end of this document you will find links to products related to this catalog. You can go directly to our shop by clicking [HERE](#). [HERE](#)

Housing - HC-D 25-TFL-58/O1M20G - 1416380

Please be informed that the data shown in this PDF Document is generated from our Online Catalog. Please find the complete data in the user's documentation. Our General Terms of Use for Downloads are valid (<http://phoenixcontact.com/download>)



Sleeve housing D25, for single locking latch, Material: Aluminum die-cast, Cable outlets: 1, straight, Height: 58 mm, Cable gland: none, Gland: Yes, 1x M20

Key Commercial Data

Packing unit	10 STK
GTIN	 4 055626 072425

Technical data

Dimensions

Height	58 mm
Width	36 mm
Length	79.5 mm

Ambient conditions

Degree of protection of housing (IP)	IP65
Ambient temperature (operation)	-40 °C ... 125 °C

General

Note	For contact inserts HC-D25, A16
Size	D25
Housing type	Sleeve housing
Locking type	for single locking latch
No. of cable outlets	1
Cable exit	straight
Screw connection	none
Type of the screw connection	1x M20
Housing material	Aluminum die-cast
Housing surface material	Powder-coated, gray
Seal material	NBR

Housing - HC-D 25-TFL-58/O1M20G - 1416380

Classifications

eCl@ss

eCl@ss 5.1	27143424
eCl@ss 8.0	27440202
eCl@ss 9.0	27440202

ETIM

ETIM 5.0	EC000437
----------	----------

Approvals

Approvals

Approvals

EAC / GL

Ex Approvals

Approvals submitted

Approval details

EAC

GL

Drawings

Housing - HC-D 25-TFL-58/O1M20G - 1416380

Dimensional drawing

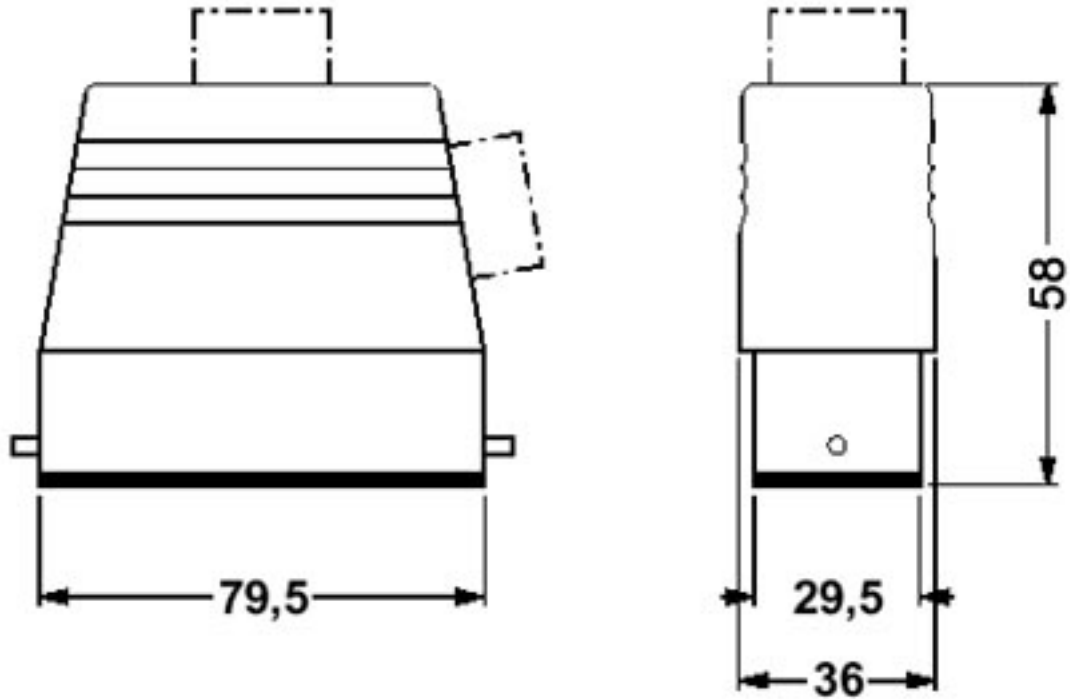

Phoenix Contact 2016 © - all rights reserved
<http://www.phoenixcontact.com>

PHOENIX CONTACT GmbH & Co. KG
Flachsmarktstr. 8
32825 Blomberg
Germany
Tel. +49 5235 300
Fax +49 5235 3 41200
<http://www.phoenixcontact.com>

Below is a list of articles with direct links to our shop Electric Automation Network where you can see:

- Quote per purchase volume in real time.
- Online documentation and datasheets of all products.
- Estimated delivery time enquiry in real time.
- Logistics systems for the shipment of materials almost anywhere in the world.
- Purchasing management, order record and tracking of shipments.

To access the product, [click on the green button.](#)

Product	Code	Reference	Product link
Sleeve housing D25, for single locking latch, Material: Aluminum die-cast, Cable outlets: 1, straight, Height: 58 mm, Cable gland: none, 1x M20	1416380	HC-D 25-TFL-58/O1M20G	Buy on EAN