



Automatización Eléctrica
Especialistas en Automatización

At the end of this document you will find links to products related to this catalog. You can go directly to our shop by clicking [HERE](#). [HERE](#)

Cable feed-through plates - MC-35/37-MULTI-67-PV-LG - 1415240

Please be informed that the data shown in this PDF Document is generated from our Online Catalog. Please find the complete data in the user's documentation. Our General Terms of Use for Downloads are valid (<http://phoenixcontact.com/download>)



Cable feed-through plates, No. of conductors: 37, Length: 92 mm, Width: 222 mm, Height: 43 mm, Color: light gray

Key Commercial Data

Packing unit	1 STK
GTIN	 4 055626 039442

Technical data

Dimensions

Length	92 mm
Width	222 mm
Height	43 mm
Drill hole distance, horizontal	62 mm
Drill hole distance, vertical	194 mm
Inside height	23 mm
Outside height	30 mm
External cable diameter	4x 6 mm ... 10 mm
	14x 8 mm ... 12 mm
	16x 10 mm ... 14 mm
	2x 12 mm ... 18 mm
	1x 17 mm ... 32 mm

Ambient conditions

Degree of protection	IP66 (Minimum sheet thickness \geq 2.5 mm)
	IP67 (Minimum sheet thickness \geq 2.5 mm)
Ambient temperature (operation)	-40 °C ... 100 °C

General

No. of conductors	37
Material	TPE-SEBS
Flammability rating according to UL 94	V0
Color	light gray

Cable feed-through plates - MC-35/37-MULTI-67-PV-LG - 1415240

Technical data

General

Torque	1.5 Nm ... 2 Nm (Mounting screws)
Note	incl. mounting screws
Installation instructions	M8 mounting screw, torque: 1.5 - 2.0 Nm, SW5 Allen key
	The mounting screws included should be used for assembly. Assembly steps: 1) Fix multigates with the mounting screws provided (observe torque), 2) Make a hole in the membrane (with screwdriver) or cut off the tip of the cone, 3) Guide the cable through the opening, 4) Strip back cable approx. 20 mm (to improve strain relief).

Standards and Regulations

Flammability rating according to UL 94	V0
--	----

Classifications

eCl@ss

eCl@ss 5.1	23110102
eCl@ss 6.0	23110102
eCl@ss 8.0	27409208

ETIM

ETIM 5.0	EC001004
----------	----------

Drawings

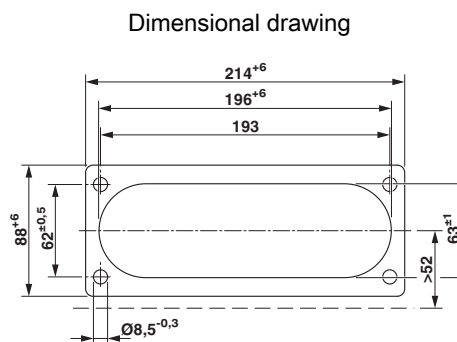
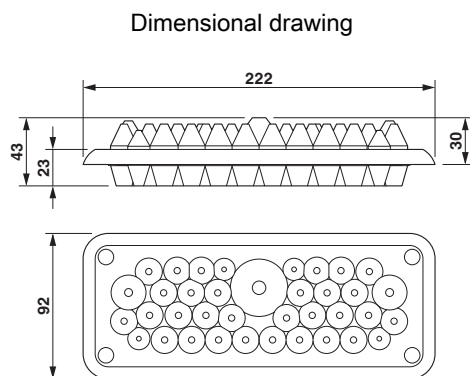

Wall cutout drawing



Below is a list of articles with direct links to our shop Electric Automation Network where you can see:

- Quote per purchase volume in real time.
- Online documentation and datasheets of all products.
- Estimated delivery time enquiry in real time.
- Logistics systems for the shipment of materials almost anywhere in the world.
- Purchasing management, order record and tracking of shipments.

To access the product, [click on the green button.](#)

Product	Code	Reference	Product link
Cable feed-through plates, No. of conductors: 37, Length: 92 mm, Width: 222 mm, Height: 43 mm, Color: light gray	1415240	MC-35/37-MULTI-67-PV-LG	Buy on EAN