



Automatización Eléctrica
Especialistas en Automatización

At the end of this document you will find links to products related to this catalog. You can go directly to our shop by clicking [HERE](#). [HERE](#)

Conductor connectors - QPD CW 4PE2,5 2X9-16 BK - 1403841

Please be informed that the data shown in this PDF Document is generated from our Online Catalog. Please find the complete data in the user's documentation. Our General Terms of Use for Downloads are valid (<http://phoenixcontact.com/download>)



Cable connector panel feed-through, two-sided with QPD nut, black, 4+PE-pos., 1.0 mm² ... 2.5 mm²/690 V/20 A, for cable diameter of 9 mm ... 16 mm.

Why buy this product

- Innovative and time saving - QUICKON fast connection for time saving of up to 80 % for on-site connection
- Convenient: quick and easy assembly without special tools
- Robust throughout: housing with IP68/IP69K and IK07 protection for a wide range of applications
- Safer connection thanks to polarization against mismatching and touch-proof protection according to DIN EN 0105
- Efficient - by using panel feed-throughs, devices no longer need to be opened in order to connect cables

Key Commercial Data

Packing unit	1 STK
GTIN	 4 046356 670371

Technical data

General

Type	QPD 5x2,5
Color	black
Locking type	Screw locking
Connection method	QUICKON connection
	IDC connection
Number of positions	5
Note number of positions	4+PE
Wrench size, union nut	27 mm
Tightening torque, union nut	10 Nm
Conductor cross section flexible min.	1 mm ²
Conductor cross section flexible max.	2.5 mm ²
Conductor cross section solid min.	1 mm ²
Conductor cross section solid max.	2.5 mm ²
Conductor cross section AWG min.	16
Conductor cross section AWG max.	14

Conductor connectors - QPD CW 4PE2,5 2X9-16 BK - 1403841

Technical data

Cabel

Structure of individual litz in acc. with VDE 0295 / smallest wire diameter	VDE 0295 class 1 to 6/min. 0.15 mm
Wire insulation material	PVC/PE/TPE/rubber
Wire diameter including insulation	2.5 mm ... 3.8 mm
External cable diameter	9 mm ... 16 mm

Ambient conditions

Degree of protection	IP68 (2 m / 24 h) IP69K
Ambient temperature (operation)	-40 °C ... 80 °C
Ambient temperature (storage/transport)	-40 °C ... 80 °C
Temperature when conductor connected	-5 °C ... 50 °C

Electrical characteristics

Nominal current I_N	20 A
Rated current	20 A
Rated voltage (III/3)	690 V
Rated voltage (III/2)	1000 V
Rated voltage (II/2)	1250 V
Rated surge voltage (III/3)	6 kV
Rated surge voltage (III/2)	8 kV
Rated surge voltage (II/2)	8 kV

Mechanical characteristics

QUICKON connectability	max. 10
Insertion/withdrawal cycles	50 (Quickon connections max. 10)

Material data

Contact material	Cu
Contact surface material	silver-plated
Contact carrier material	PA
Insulating material	PA
Flammability rating according to UL 94	V0
Overvoltage category	III
Degree of pollution	3

Standards and Regulations

Flammability rating according to UL 94	V0
--	----

Classifications

eCl@ss

eCl@ss 4.0	272607xx
eCl@ss 4.1	27260701

Conductor connectors - QPD CW 4PE2,5 2X9-16 BK - 1403841

Classifications

eCl@ss

eCl@ss 5.0	27143424
eCl@ss 5.1	27143424
eCl@ss 6.0	27143424
eCl@ss 7.0	27440209
eCl@ss 8.0	27440605

ETIM

ETIM 3.0	EC000516
ETIM 4.0	EC002635
ETIM 5.0	EC002560

UNSPSC

UNSPSC 6.01	30211923
UNSPSC 7.0901	39121522
UNSPSC 11	39121522
UNSPSC 12.01	39121522
UNSPSC 13.2	39121522

Approvals

Approvals

Approvals

VDE Zeichengenehmigung / IECCEB Scheme / GL / EAC

Ex Approvals

Approvals submitted

Approval details

VDE Zeichengenehmigung 	
mm ² /AWG/kcmil	1.0-2.5
Nominal current I _N	20 A
Nominal voltage U _N	690 V

Conductor connectors - QPD CW 4PE2,5 2X9-16 BK - 1403841

Approvals

IECEE CB Scheme	
Nominal voltage UN	690 V

GL

EAC

Drawings

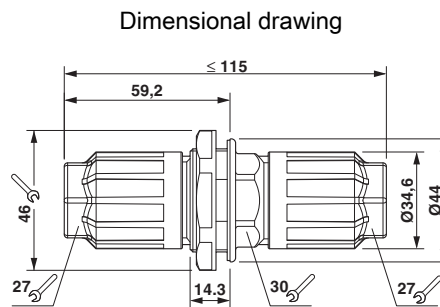

Dimensional drawing of the QPD CW 5x2.5

Phoenix Contact 2016 © - all rights reserved
<http://www.phoenixcontact.com>

PHOENIX CONTACT GmbH & Co. KG
Flachsmarktstr. 8
32825 Blomberg
Germany
Tel. +49 5235 300
Fax +49 5235 3 41200
<http://www.phoenixcontact.com>

Below is a list of articles with direct links to our shop Electric Automation Network where you can see:

- Quote per purchase volume in real time.
- Online documentation and datasheets of all products.
- Estimated delivery time enquiry in real time.
- Logistics systems for the shipment of materials almost anywhere in the world.
- Purchasing management, order record and tracking of shipments.

To access the product, [click on the green button.](#)

Product	Code	Reference	Product link
Cable connector panel feed-through, two-sided with QPD nut, black, 4+PE-pos., 1.0 mm ² ... 2.5 mm ² /690 V/20 A, for cable diameter of 9 mm ... 16 mm.	1403841	QPD CW 4PE2,5 2X9-16 BK	Buy on EAN