



Automatización Eléctrica
Especialistas en Automatización

At the end of this document you will find links to products related to this catalog. You can go directly to our shop by clicking [HERE](#). [HERE](#)

Snap-on frame - CES-B16-SF-PLBK - 0801651

Please be informed that the data shown in this PDF Document is generated from our Online Catalog. Please find the complete data in the user's documentation. Our General Terms of Use for Downloads are valid (<http://phoenixcontact.com/download>)



Size B16 snap-on frame including integrated mounting panel seal, for accommodating CES-B16-HFFS-PLBK or CES-B16-SFFS-PLBK sealing frames

Product Description

Snap-on frame, medium

Key Commercial Data

Packing unit	10 STK
GTIN	 4 046356 674164

Technical data

Dimensions

Length	128 mm
Width	64 mm
Height	38 mm

Ambient conditions

Degree of protection	IP54
Ambient temperature (operation)	-20 °C ... 80 °C

General

Product description	Snap-on frame, medium
Frame type	Snap-on frame
Material	PA
Flammability rating according to UL 94	V0
Color	black
Installation instructions	M4 mounting screw. 1.8 Nm torque
	A video tutorial on how to assemble the product can be found in the Downloads area, in the Video category.
	Leak-tightness is guaranteed with underwall and perpendicular mounting.

Standards and Regulations

Flammability rating according to UL 94	V0
--	----

Snap-on frame - CES-B16-SF-PLBK - 0801651

Classifications

eCl@ss

eCl@ss 4.0	27081002
eCl@ss 4.1	27081002
eCl@ss 5.0	27081002
eCl@ss 5.1	27081002
eCl@ss 6.0	27081002
eCl@ss 7.0	27081002
eCl@ss 8.0	27069220

ETIM

ETIM 3.0	EC000451
ETIM 4.0	EC000451
ETIM 5.0	EC000451

UNSPSC

UNSPSC 6.01	30212109
UNSPSC 7.0901	39121708
UNSPSC 11	39121708
UNSPSC 12.01	39121708
UNSPSC 13.2	39121708

Approvals

Approvals

Approvals

GL

Ex Approvals

Approvals submitted

Approval details

GL

Drawings

Snap-on frame - CES-B16-SF-PLBK - 0801651

Dimensional drawing

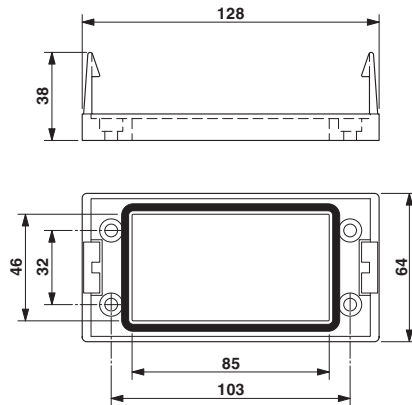

Dimensional drawing

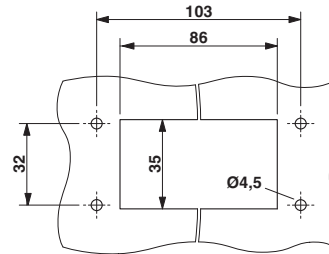

Panel cutout

Dimensional drawing

Phoenix Contact 2016 © - all rights reserved
<http://www.phoenixcontact.com>

PHOENIX CONTACT GmbH & Co. KG
Flachsmarktstr. 8
32825 Blomberg
Germany
Tel. +49 5235 300
Fax +49 5235 3 41200
<http://www.phoenixcontact.com>



Automatización Eléctrica
Especialistas en Automatización

Below is a list of articles with direct links to our shop Electric Automation Network where you can see:

- Quote per purchase volume in real time.
- Online documentation and datasheets of all products.
- Estimated delivery time enquiry in real time.
- Logistics systems for the shipment of materials almost anywhere in the world.
- Purchasing management, order record and tracking of shipments.

To access the product, [click on the green button.](#)

Product	Code	Reference	Product link
Size B16 snap-on frame including integrated mounting panel seal, for accommodating CES-B16-HFFS-PLBK or CES-B16-SFFS-PLBK sealing frames	0801651	CES-B16-SF-PLBK	Buy on EAN