

The OMRON logo is displayed in a bold, blue, sans-serif font. The letters are thick and rounded, with the 'O' being a simple circle. The entire logo is set against a light yellow rectangular background.

Automatización Eléctrica
Especialistas en Automatización

At the end of this document you will find links to products related to this catalog. You can go directly to our shop by clicking [HERE](#). [HERE](#)

SYSMAC CJ Series
CJ2M-CPU_
CJ2M-MD21_

CJ2M CPU Unit
Pulse I/O Module

USERS MANUAL

OMRON

© **OMRON, 2010**

All rights reserved. No part of this publication may be reproduced, stored in a retrieval system, or transmitted, in any form, or by any means, mechanical, electronic, photocopying, recording, or otherwise, without the prior written permission of OMRON.

No patent liability is assumed with respect to the use of the information contained herein. Moreover, because OMRON is constantly striving to improve its high-quality products, the information contained in this manual is subject to change without notice. Every precaution has been taken in the preparation of this manual. Nevertheless, OMRON assumes no responsibility for errors or omissions. Neither is any liability assumed for damages resulting from the use of the information contained in this publication.

SYSMAC CJ Series

CJ2M-CPU□□

+

CJ2M-CPU□□

(Pulse I/O Module)

CJ2M CPU Unit Pulse I/O Module

User's Manual

Produced July 2010

Introduction

Thank you for purchasing a CJ2M-CPU□□ CPU Unit for a CJ-series Programmable Controller. This manual provides information that is necessary to use a CJ2M-MD211 or CJ2M-MD212 Pulse I/O Module connected to a CJ2M CPU Unit. Read this manual completely and be sure you understand the contents before attempting to use a Pulse I/O Module.

Intended Audience

This manual is intended for the following personnel, who must also have knowledge of electrical systems (an electrical engineer or the equivalent).

- Personnel in charge of installing FA systems
- Personnel in charge of designing FA systems.
- Personnel in charge of managing FA systems and facilities.

Applicable Products

CJ-series CP2 CPU Units



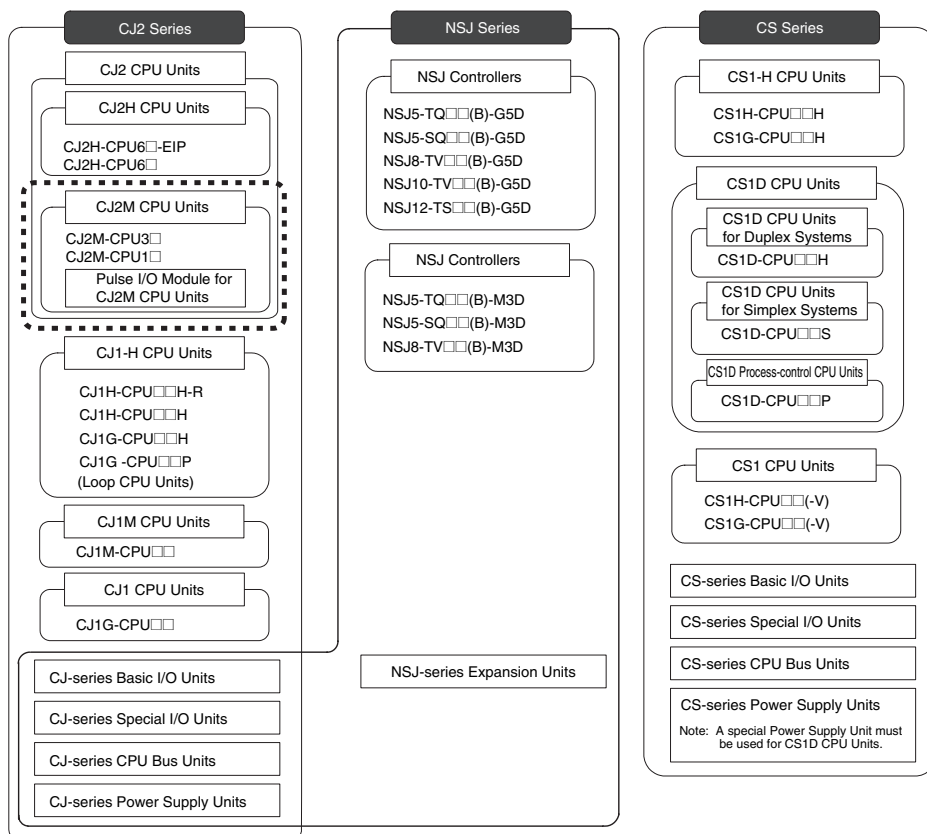

- CJ2M-CPU3□
- CJ2M-CPU1□

Note This manual refers to one or more CPU Units using the generic model number CJ2M-CPU□□.



CJ2 CPU Unit Manuals

Information on the CJ2 CPU Units is provided in the following manuals. Refer to the appropriate manual for the information that is required.

	 CJ-series CJ2 CPU Unit Hardware User's Manual (Cat. No. W472)	 CJ-series CJ2 CPU Unit Software User's Manual (Cat. No. W473)	 CS/CJ/NSJ Series Instructions Reference Manual (Cat. No. W474)	 This Manual CJ2M CPU Unit Pulse I/O Module User's Manual (Cat. No. W486)
1 Mounting and Setting Hardware	<ul style="list-style-type: none"> Unit part names and specifications Basic system configuration Unit mounting procedure Setting procedure for DIP switch and rotary switches on the front of the CPU Unit <p>For details on built-in EtherNet/IP port, refer to the <i>EtherNet/IP Unit Operation Manual (W465)</i></p>			<ul style="list-style-type: none"> Specifications and wiring of Pulse I/O Modules Available pulse I/O functions and allocations
2 Wiring				
3 Connecting Online to the PLC	<ul style="list-style-type: none"> Wiring the Power Supply Unit Wiring Basic I/O Units and external I/O devices 			<ul style="list-style-type: none"> Wiring methods between Pulse I/O Modules and external I/O devices
4 Software Setup	CX-Programmer Support Software Connecting Cables	Procedures for connecting the CX-Programmer Support Software		
5 Creating the Program		Software setting methods for the CPU Unit (including I/O memory allocation, PLC Setup settings, Special I/O Unit parameters, CPU Bus Unit parameters, and routing tables.) For details on built-in EtherNet/IP port, refer to the <i>EtherNet/IP Unit Operation Manual (W465)</i> .		Software setting procedures for Pulse I/O Modules (I/O memory allocations and PLC Setup settings)
6 Checking and Debugging Operation		<ul style="list-style-type: none"> Program types and basic information CPU Unit operation Internal memory Data management using file memory in the CPU Unit Built-in CPU functions Settings 	Detailed information on programming instructions	Pulse I/O functions
7 Maintenance and Troubleshooting		<ul style="list-style-type: none"> Checking I/O wiring, setting the Auxiliary Area settings, and performing trial operation Monitoring and debugging with the CX-Programmer 		
	Error codes and remedies if a problem occurs			

Manual Configuration

The CJ2 CPU manuals are organized in the sections listed in the following tables. Refer to the appropriate section in the manuals as required.

Hardware User's Manual (Cat. No. W472)

Section	Content
Section 1 Overview	This section gives an overview of the CJ2 CPU Units and describes the features and specifications.
Section 2 Basic System Configuration and Devices	This section describes the system configuration for the CJ2 CPU Unit.
Section 3 Nomenclature and Functions	This section describes the part names and functions of the CPU Unit and Configuration Units.
Section 4 Support Software	This section describes the types of Support Software to use to perform programming and debugging and how to connect the PLC to the Support Software.
Section 5 Installation	This section describes the installation locations and how to wire CPU Units and Configuration Units.
Section 6 Troubleshooting	This section describes how to check the status for errors that occur during system operation and the remedies for those errors.
Section 7 Inspection and Maintenance	This section describes periodic inspection, the service life of the Battery and Power Supply Unit, and how to replace the Battery.
Section 8 Backup Operations	This section describes the procedure to back up PLC data.
Appendices	The appendices provide Unit dimensions, details on fatal and non-fatal errors, information on connecting to serial ports on the CPU Unit, the procedure for installing the USB driver on a computer, and information on load short-circuit protection and line disconnection detection.

Software User's Manual (Cat. No. W473)

Section	Content
Section 1 Overview	This section gives an overview of the CJ2 CPU Units and describes the features and specifications.
Section 2 Internal Memory in the CPU Unit	This section describes the types of memory in the CPU Unit and the data that is stored.
Section 3 CPU Unit Operation	This section describes the internal operation of the CPU Unit.
Section 4 CPU Unit Initialization	This section describes the initial setup of the CPU Unit.
Section 5 Understanding Programming	This section describes program types and programming details, such as symbols and programming instructions.
Section 6 I/O Memory Areas	This section describes the I/O memory areas in the CPU Unit.
Section 7 File Operations	This section describes the files that can be stored in the CPU Unit, the storage destination for those files, and file operations.
Section 8 I/O Allocations and Unit Settings	This section describes the I/O allocations used to exchange data between the CPU Unit and other Units.
Section 9 PLC Setup	This section describes details on the PLC Setup settings, which are used to perform basic settings for the CPU Unit.
Section 10 CPU Unit Functions	This section describes functions that are built into the CPU Unit.
Section 11 Programming Devices and Communications	This section describes the procedure for connecting the CJ2 CPU Unit to the CX-Programmer or other Support Software and to other devices.
Section 12 CPU Unit Cycle Time	This section describes how to monitor and calculate the cycle time.
Appendices	The appendices provide information on programming instructions, execution times, number of steps, Auxiliary Area words and bits, a memory map of the continuous PLC memory addresses, I/O memory operation when power is interrupted, and a comparison of CJ-series and CS-series PLCs.

Instructions Reference Manual (Cat. No. W474)

Section	Content
Section 1 Basic Understanding of Instructions	This section provides basic information on designing ladder programs for a CS/CJ/NSJ-series CPU Unit.
Section 2 Summary of Instructions	This section provides a summary of instructions used with a CS/CJ/NSJ-series CPU Unit.
Section 3 Instructions	This section describes the functions, operands and sample programs of the instructions that are supported by a CS/CJ/NSJ-series CPU Unit.
Section 4 Instruction Execution Times and Number of Steps	This section provides the instruction execution times for each CS/CJ/NSJ-series CPU Unit instruction.
Appendices	The appendices provide a list of instructions by function code and by mnemonic and an ASCII table for the CS/CJ/NSJ-series CPU Units.

Pulse I/O Module User's Manual (Cat. No. W486) (This Manual)

Section	Content
Section 1 Overview	This section gives an overview of the Pulse I/O Module and describes its features.
Section 2 I/O Application Procedures and Function Allocations	This section lists the pulse functions of the CJ2M CPU Units and describes the overall application flow and the allocation of the functions.
Section 3 I/O Specifications and Wiring for Pulse I/O Modules	This section provides the specifications and describes the wiring of the Pulse I/O Module.
Section 4 Normal I/O	This section describes the normal I/O.
Section 5 Quick-response Inputs	This section describes the quick-response function that can be used to input signals that are shorter than the cycle time.
Section 6 Interrupts	This section describes the interrupt input function.
Section 7 High-speed Counters	This section describes the high-speed counter inputs and high-speed counter interrupts.
Section 8 Pulse Outputs	This section describes positioning functions, such as trapezoidal control, S-curve control, jogging, and origin search functions.
Section 9 PWM Outputs	This section describes the variable-duty-factor pulse (PWM) outputs.
Appendices	The appendices provide a table of flag changes for pulse outputs, a comparison table with other models, and a performance table.

Manual Structure

Page Structure

The following page structure is used in this manual.

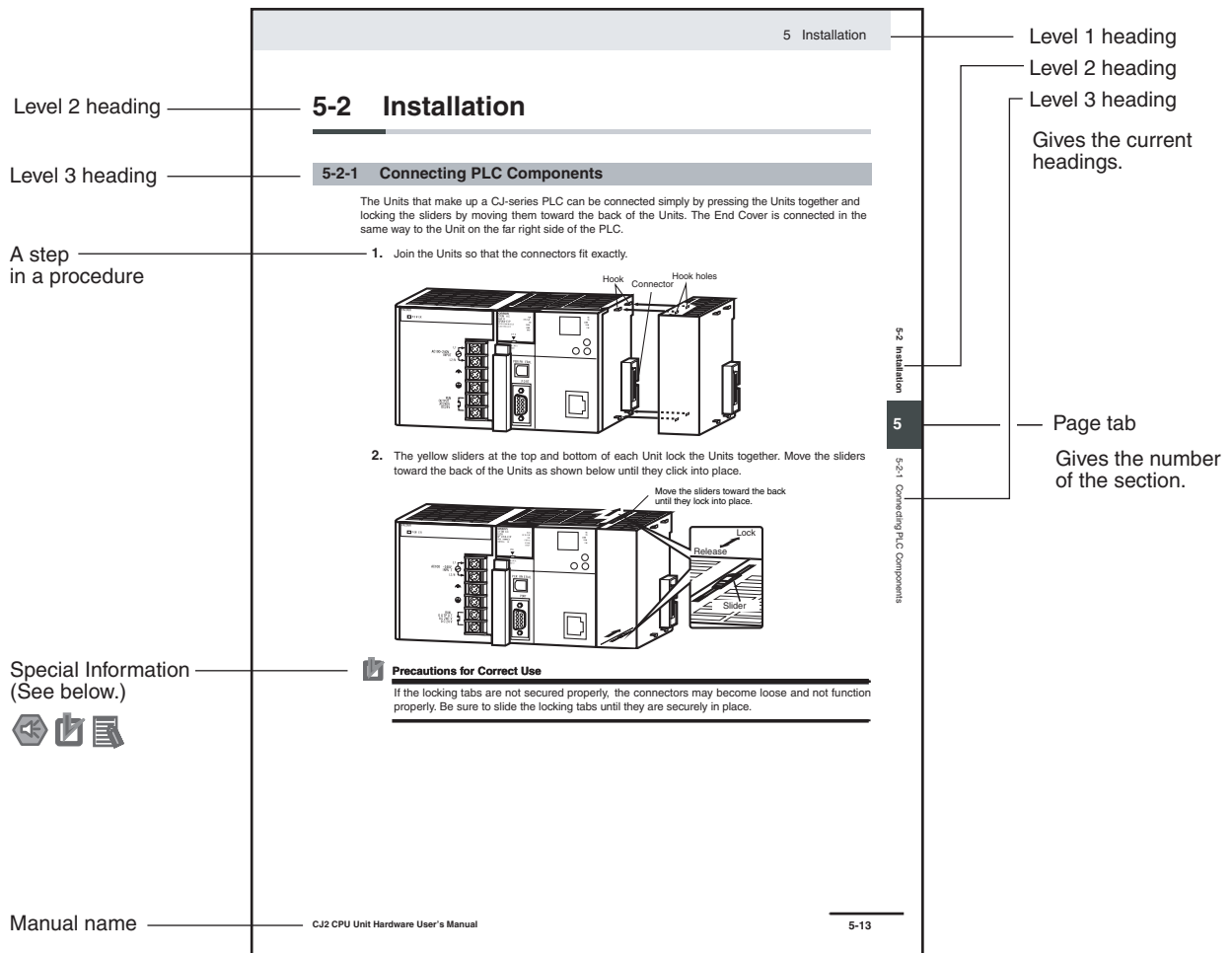

This illustration is provided only as a sample and may not literally appear in this manual.

Special Information

Special information in this manual is classified as follows:



Precautions for Safe Use

Precautions on what to do and what not to do to ensure using the product safely.



Precautions for Correct Use

Precautions on what to do and what not to do to ensure proper operation and performance.



Additional Information

Additional information to increase understanding or make operation easier.

Sections in this Manual

1	Overview	1
2	I/O Application Procedures and Function Allocations	2
3	I/O Specifications and Wiring for Pulse I/O Modules	3
4	Normal I/O	4
5	Quick-response Inputs	5
6	Interrupts	6
7	High-speed Counters	7
8	Pulse Outputs	8
9	PWM Outputs	9
A	Appendices	A

CONTENTS

Introduction	1
CJ2 CPU Unit Manuals	2
Manual Structure	5
Sections in this Manual	7
Safety Precautions	17
Application Precautions.....	21
Operating Environment Precautions	26
Regulations and Standards	27
Unit Versions of CJ2 CPU Units	30
Related Manuals	31

Section 1 Overview

1-1 Pulse I/O Modules.....	1-2
1-2 Overview of the Functions of CJ2M Pulse I/O	1-4
1-3 Functions of CJ2M Pulse I/O	1-6

Section 2 I/O Application Procedures and Function Allocations

2-1 Pulse I/O Module Application Procedure	2-2
2-2 Allocating I/O Functions	2-4
2-2-1 Specifying the Functions to Use	2-4
2-2-2 Selecting Functions in the PLC Setup	2-4
2-2-3 Allocating Functions to Input Terminals	2-5
2-2-4 Allocating Functions to Output Terminals	2-7
2-3 PLC Setup	2-8
2-3-1 Normal Input Operation Setting	2-9
2-3-2 Interrupt Input and Quick-response Input Detailed Settings	2-9
2-3-3 High-speed Counter Settings.....	2-10
2-3-4 Pulse Output and Origin Search Settings.....	2-11

Section 3 I/O Specifications and Wiring for Pulse I/O Modules

3-1 I/O Specifications	3-2
3-1-1 Input Specifications.....	3-2
3-1-2 Output Specifications for Sinking Transistor Outputs.....	3-4
3-1-3 Output Specifications for Sourcing Transistor Outputs	3-5
3-2 Wiring	3-7
3-2-1 Connector Pin Allocations.....	3-7
3-2-2 I/O Circuit Configurations.....	3-8
3-2-3 Wiring	3-8

Section 4 Normal I/O

4-1	Normal Inputs	4-2
4-1-1	Overview	4-2
4-1-2	Application Procedure	4-2
4-2	Normal Outputs	4-5
4-2-1	Overview	4-5
4-2-2	Flow of Operation	4-5
4-3	Wiring	4-7
4-3-1	Connector Pin Assignments	4-7
4-3-2	Wiring Examples	4-9

Section 5 Quick-response Inputs

5-1	Overview	5-2
5-2	Application Procedure	5-3
5-2-1	PLC Setup	5-3
5-2-2	Applicable Input Terminals	5-5
5-3	Wiring	5-6
5-3-1	Connector Pin Assignments	5-6
5-4	Creating Ladder Programs	5-7

Section 6 Interrupts

6-1	Types of Interrupts	6-2
6-1-1	Overview	6-2
6-2	Interrupt Inputs	6-3
6-2-1	Overview	6-3
6-2-2	Application Procedure	6-5
6-2-3	Specifications	6-5
6-2-4	PLC Setup	6-6
6-2-5	Wiring	6-10
6-2-6	Creating Ladder Programs	6-10
6-2-7	Application Example	6-14

Section 7 High-speed Counters

7-1	Overview	7-2
7-1-1	Overview	7-2
7-1-2	Application Procedure	7-3
7-1-3	Specifications	7-3
7-1-4	PLC Setup	7-4
7-1-5	Wiring	7-7
7-1-6	Creating Ladder Programs	7-12
7-2	High-speed Counter Inputs	7-13
7-2-1	Pulse Input Methods Settings	7-13
7-2-2	Counting Mode Settings	7-14
7-2-3	Reset Methods	7-16
7-2-4	Reading the Present Value	7-16
7-2-5	Frequency Measurement	7-17
7-2-6	Measuring the Rotational Speed or Total Rotations	7-18
7-2-7	Reading the Count Direction	7-19
7-2-8	Temporarily Stopping Input Signal Counting (Gate Function)	7-20

7-3	High-speed Counter Interrupts	7-21
7-3-1	Overview	7-21
7-3-2	Present Value Comparison	7-25
7-3-3	High-speed Counter Interrupt Instructions	7-28
7-4	Related Auxiliary Area Words and Bits	7-35
7-5	Application Examples	7-43

Section 8 Pulse Outputs

8-1	Overview	8-3
8-1-1	Overview	8-3
8-1-2	Application Procedure	8-4
8-1-3	Specifications	8-5
8-1-4	Wiring	8-11
8-2	Position Control	8-27
8-2-1	Position Control Configuration	8-27
8-2-2	Relative Positioning and Absolute Positioning	8-28
8-2-3	Application Example	8-30
8-3	Jogging	8-32
8-3-1	High-speed Jogging	8-32
8-3-2	Low-speed Jogging	8-32
8-3-3	Application Example	8-33
8-4	Implementing Interrupt Feeding	8-35
8-4-1	Using the IFEED(892) (INTERRUPT FEEDING) Instruction	8-35
8-4-2	Setting Procedure	8-35
8-4-3	PLC Setup	8-36
8-4-4	INTERRUPT FEEDING Instruction: IFEED(892)	8-37
8-5	Defining the Origin	8-39
8-5-1	Origin Searches	8-39
8-5-2	Setting Procedure	8-40
8-5-3	PLC Setup	8-40
8-5-4	Origin Search Instructions	8-45
8-5-5	Origin Search Operations	8-46
8-5-6	Origin Return	8-51
8-5-7	Changing the PV of the Pulse Output	8-52
8-5-8	Application Example	8-52
8-6	Reading the Pulse Output Present Value	8-56
8-7	Reading the Pulse Output Frequency	8-57
8-8	Related Auxiliary Area Bits	8-58
8-9	Application Example	8-63
8-9-1	Cutting Long Material Using Fixed Feeding	8-63
8-9-2	Palletize: Two-axis Multipoint Positioning	8-66
8-9-3	Vertically Conveying PCBs (Multiple Progressive Positioning)	8-74
8-9-4	Feeding Wrapping Material: Interrupt Feeding	8-80
8-10	Precautions when Using Pulse Outputs	8-82
8-11	Pulse Output Patterns	8-87
8-11-1	Speed Control (Continuous Mode)	8-87
8-11-2	Positioning Control (Independent Mode)	8-89

Section 9 PWM Outputs

9-1	PWM Outputs (Variable Duty Ratio Pulse Outputs)	9-2
9-1-1	Overview	9-2
9-1-2	Application Procedure	9-3
9-1-3	Wiring	9-4
9-1-4	Ladder Program Example	9-5

Appendices

A-1	Flag Operations during Pulse Output	A-2
A-2	Combinations of Pulse Control Instructions	A-3
A-3	Comparison to CJ1M Built-in I/O Functions	A-7
A-4	Performance Information	A-10
A-4-1	Interrupt Input Response Time	A-10
A-4-2	Pulse Output Start Time.....	A-11
A-4-3	Response Times of Pulse Output Changes	A-11

Index	Index-1
--------------------	----------------

Revision History	Revision-1
-------------------------------	-------------------

Read and Understand this Manual

Please read and understand this manual before using the product. Please consult your OMRON representative if you have any questions or comments.

Warranty and Limitations of Liability

WARRANTY

OMRON's exclusive warranty is that the products are free from defects in materials and workmanship for a period of one year (or other period if specified) from date of sale by OMRON.

OMRON MAKES NO WARRANTY OR REPRESENTATION, EXPRESS OR IMPLIED, REGARDING NON-INFRINGEMENT, MERCHANTABILITY, OR FITNESS FOR PARTICULAR PURPOSE OF THE PRODUCTS. ANY BUYER OR USER ACKNOWLEDGES THAT THE BUYER OR USER ALONE HAS DETERMINED THAT THE PRODUCTS WILL SUITABLY MEET THE REQUIREMENTS OF THEIR INTENDED USE. OMRON DISCLAIMS ALL OTHER WARRANTIES, EXPRESS OR IMPLIED.

LIMITATIONS OF LIABILITY

OMRON SHALL NOT BE RESPONSIBLE FOR SPECIAL, INDIRECT, OR CONSEQUENTIAL DAMAGES, LOSS OF PROFITS OR COMMERCIAL LOSS IN ANY WAY CONNECTED WITH THE PRODUCTS, WHETHER SUCH CLAIM IS BASED ON CONTRACT, WARRANTY, NEGLIGENCE, OR STRICT LIABILITY.

In no event shall the responsibility of OMRON for any act exceed the individual price of the product on which liability is asserted.

IN NO EVENT SHALL OMRON BE RESPONSIBLE FOR WARRANTY, REPAIR, OR OTHER CLAIMS REGARDING THE PRODUCTS UNLESS OMRON'S ANALYSIS CONFIRMS THAT THE PRODUCTS WERE PROPERLY HANDLED, STORED, INSTALLED, AND MAINTAINED AND NOT SUBJECT TO CONTAMINATION, ABUSE, MISUSE, OR INAPPROPRIATE MODIFICATION OR REPAIR.

Application Considerations

SUITABILITY FOR USE

OMRON shall not be responsible for conformity with any standards, codes, or regulations that apply to the combination of products in the customer's application or use of the products.

At the customer's request, OMRON will provide applicable third party certification documents identifying ratings and limitations of use that apply to the products. This information by itself is not sufficient for a complete determination of the suitability of the products in combination with the end product, machine, system, or other application or use.

The following are some examples of applications for which particular attention must be given. This is not intended to be an exhaustive list of all possible uses of the products, nor is it intended to imply that the uses listed may be suitable for the products:

- Outdoor use, uses involving potential chemical contamination or electrical interference, or conditions or uses not described in this manual.
- Nuclear energy control systems, combustion systems, railroad systems, aviation systems, medical equipment, amusement machines, vehicles, safety equipment, and installations subject to separate industry or government regulations.
- Systems, machines, and equipment that could present a risk to life or property.

Please know and observe all prohibitions of use applicable to the products.

NEVER USE THE PRODUCTS FOR AN APPLICATION INVOLVING SERIOUS RISK TO LIFE OR PROPERTY WITHOUT ENSURING THAT THE SYSTEM AS A WHOLE HAS BEEN DESIGNED TO ADDRESS THE RISKS, AND THAT THE OMRON PRODUCTS ARE PROPERLY RATED AND INSTALLED FOR THE INTENDED USE WITHIN THE OVERALL EQUIPMENT OR SYSTEM.

PROGRAMMABLE PRODUCTS

OMRON shall not be responsible for the user's programming of a programmable product, or any consequence thereof.

Disclaimers

CHANGE IN SPECIFICATIONS

Product specifications and accessories may be changed at any time based on improvements and other reasons.

It is our practice to change model numbers when published ratings or features are changed, or when significant construction changes are made. However, some specifications of the products may be changed without any notice. When in doubt, special model numbers may be assigned to fix or establish key specifications for your application on your request. Please consult with your OMRON representative at any time to confirm actual specifications of purchased products.

DIMENSIONS AND WEIGHTS

Dimensions and weights are nominal and are not to be used for manufacturing purposes, even when tolerances are shown.

PERFORMANCE DATA

Performance data given in this manual is provided as a guide for the user in determining suitability and does not constitute a warranty. It may represent the result of OMRON's test conditions, and the users must correlate it to actual application requirements. Actual performance is subject to the OMRON Warranty and Limitations of Liability.

ERRORS AND OMISSIONS

The information in this manual has been carefully checked and is believed to be accurate; however, no responsibility is assumed for clerical, typographical, or proofreading errors, or omissions.

Safety Precautions

Definition of Precautionary Information

The following notation is used in this manual to provide precautions required to ensure safe usage of a CJ-series PLC. The safety precautions that are provided are extremely important to safety. Always read and heed the information provided in all safety precautions.



WARNING

Indicates a potentially hazardous situation which, if not avoided, could result in death or serious injury. Additionally, there may be severe property damage.



Caution

Indicates a potentially hazardous situation which, if not avoided, may result in minor or moderate injury, or property damage.



Precautions for Safe Use

Indicates precautions on what to do and what not to do to ensure using the product safely.



Precautions for Correct Use

Indicates precautions on what to do and what not to do to ensure proper operation and performance.

Symbols



The triangle symbol indicates precautions (including warnings). The specific operation is shown in the triangle and explained in text. This example indicates a precaution for electric shock.



The circle and slash symbol indicates operations that you must not do. The specific operation is shown in the circle and explained in text.



The filled circle symbol indicates operations that you must do. The specific operation is shown in the circle and explained in text. This example shows a general precaution for something that you must do.



The triangle symbol indicates precautions (including warnings). The specific operation is shown in the triangle and explained in text. This example indicates a general precaution.



The triangle symbol indicates precautions (including warnings). The specific operation is shown in the triangle and explained in text. This example indicates a precaution for hot surfaces.

WARNING

Do not attempt to take any Unit apart or touch the inside of any Unit while the power is being supplied. Doing so may result in electric shock.



Do not touch any of the terminals or terminal blocks while the power is being supplied. Doing so may result in electric shock.



Provide safety measures in external circuits (i.e., not in the Programmable Controller), including the following items, to ensure safety in the system if an abnormality occurs due to malfunction of the Programmable Controller or another external factor affecting the operation of the Programmable Controller. “Programmable Controller” indicates the CPU Unit and all other Units and is abbreviated “PLC” in this manual. Not doing so may result in serious accidents.



- Emergency stop circuits, interlock circuits, limit circuits, and similar safety measures must be provided in external control circuits.
- The PLC will turn OFF all outputs when its self-diagnosis function detects any error or when a severe failure alarm (FALS) instruction is executed. Unexpected operation, however, may still occur for errors in the I/O control section, errors in I/O memory, and other errors that cannot be detected by the self-diagnosis function. As a countermeasure for all such errors, external safety measures must be provided to ensure safety in the system.
- The PLC outputs may remain ON or OFF due to deposition or burning of the output relays or destruction of the output transistors. As a countermeasure for such problems, external safety measures must be provided to ensure safety in the system.
- Provide measures in the computer system and programming to ensure safety in the overall system even if communications errors or malfunctions occur in data link communications or remote I/O communications.

Confirm safety before transferring data files stored in the file memory (Memory Card or EM file memory) to the I/O area (CIO) of the CPU Unit using a peripheral tool. Otherwise, the devices connected to the output unit may malfunction regardless of the operation mode of the CPU Unit.



Fail-safe measures must be taken by the customer to ensure safety in the event of incorrect, missing, or abnormal signals caused by broken signal lines, momentary power interruptions, or other causes. Serious accidents may result from abnormal operation if proper measures are not provided.



Caution

Execute online edit only after confirming that no adverse effects will be caused by extending the cycle time. Otherwise, the input signals may not be readable.



Confirm safety at the destination node before transferring a program, PLC Setup, I/O tables, I/O memory contents, or parameters to another node or changing contents of any of these items. Transferring or changing data can result in unexpected system operation.



The CJ2 CPU Units automatically back up the user program and parameter data to flash memory when these are written to the CPU Unit. I/O memory (including the DM, EM, and Holding Areas), however, is not written to flash memory.

The DM, EM, and Holding Areas can be held during power interruptions with a battery. If there is a battery error, the contents of these areas may not be accurate after a power interruption. If the contents of the DM, EM, and Holding Areas are used to control external outputs, prevent inappropriate outputs from being made whenever the Battery Error Flag (A402.04) is ON.



Tighten the terminal screws on the AC Power Supply Unit to the torque specified in the operation manual. The loose screws may result in burning or malfunction.



Do not touch the Power Supply Unit when power is being supplied or immediately after the power supply is turned OFF. The Power Supply Unit will be hot and you may be burned.



When connecting a personal computer or other peripheral device to a PLC to which a non-insulated Power Supply Unit (CJ1W-PD022) is mounted, either ground the 0 V side of the external power supply or do not ground the external power supply at all ground. A short-circuit will occur in the external power supply if incorrect grounding methods are used. Never ground the 24 V side, as shown below.



Wiring in Which the 24-V Power Supply Will Short

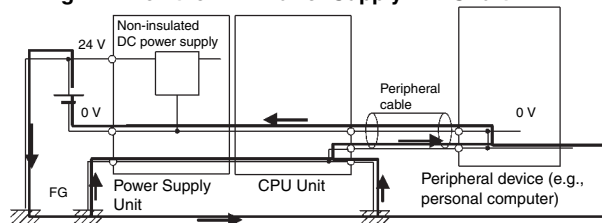

Application Precautions

Observe the following precautions when using a CJ-series PLC.

● Power Supply

- Always use the power supply voltages specified in the user's manuals. An incorrect voltage may result in malfunction or burning.
- Exceeding the capacity of the Power Supply Unit may prevent the CPU Unit or other Units from starting.
- Take appropriate measures to ensure that the specified power with the rated voltage and frequency is supplied. Be particularly careful in places where the power supply is unstable. An incorrect power supply may result in malfunction.
- Always turn OFF the power supply to the PLC before attempting any of the following. Not turning OFF the power supply may result in malfunction or electric shock.
 - Mounting or dismounting Power Supply Units, I/O Units, CPU Units, Option Boards, Pulse I/O Modules or any other Units.
 - Assembling the Units.
 - Setting DIP switches or rotary switches.
 - Connecting cables or wiring the system.
 - Connecting or disconnecting the connectors.
- When cross-wiring terminals, the total current for all the terminal will flow in the wire. Make sure that the current capacity of the wire is sufficient.
- Observe the following precautions when using a Power Supply Unit that supports the Replacement Notification Function.
 - Replace the Power Supply Unit within six months if the display on the front of the Power Supply Unit alternates between 0.0 and A02, or if the alarm output automatically turns OFF.
 - Keep the alarm output cable separated from power line and high-voltage lines.
 - Do not apply a voltage or connect a load exceeding the specifications to the alarm output.
 - When storing the Power Supply Unit for more than three months, store it at -20 to 30°C and 25% to 70% humidity to preserve the Replacement Notification Function.
 - If the Power Supply Unit is not installed properly, heat buildup may cause the replacement notification signal to appear at the wrong time or may cause interior elements to deteriorate or become damaged. Use only the standard installation method.
- Do not touch the terminals on the Power Supply Unit immediately after turning OFF the power supply. Residual voltage may cause electrical shock.
- Observe the following precautions to prevent failure due to difference in electrical potential if the computer is connected to the PLC.
 - Before connecting a laptop computer to the PLC, disconnect the power supply plug of the computer from the AC outlet. Residual current in the AC adaptor may cause difference in electrical potential to occur between the computer and the PLC. After you connect the computer and PLC, supply the power again from the AC adaptor.
 - If the computer has an FG terminal, make the connections so that it has the same electrical potential as the FG (GR) terminal on the PLC.
- If the computer is grounded to a separate location, difference in electrical potential may occur depending on the grounding conditions.

● Installation

- Do not install the PLC near sources of strong high-frequency noise.
- Before touching a Unit, be sure to first touch a grounded metallic object in order to discharge any static build-up. Not doing so may result in malfunction or damage.

- Be sure that the terminal blocks, connectors, Memory Cards, Option Boards, Pulse I/O Modules, expansion cables, and other items with locking devices are properly locked into place.
- The sliders on the tops and bottoms of the Power Supply Unit, CPU Unit, I/O Units, Special I/O Units, CPU Bus Units, and Pulse I/O Modules must be completely locked (until they click into place) after connecting to adjacent Units. It may not be possible to achieve proper functionality if the sliders are not locked.

● Wiring

- Follow the instructions in this manual to correctly perform wiring.
- Double-check all wiring and switch settings before turning ON the power supply. Incorrect wiring may result in burning.
- Be sure that all terminal screws, and cable connector screws are tightened to the torque specified in the relevant manuals. Incorrect tightening torque may result in malfunction.
- Mount terminal blocks and connectors only after checking the mounting location carefully.
- Leave the label attached to the Unit when wiring. Removing the label may result in malfunction if foreign matter enters the Unit.
- Remove the label after the completion of wiring to ensure proper heat dissipation. Leaving the label attached may result in malfunction.
- Use crimp terminals for wiring. Do not connect bare stranded wires directly to terminals. Connection of bare stranded wires may result in burning.
- Do not apply voltages to the Input Units in excess of the rated input voltage. Excess voltages may result in burning.
- Always connect to a ground of 100 Ω or less when installing the Units. Not connecting to a ground of 100 Ω or less may result in electric shock.
A ground of 100 Ω or less must be installed when shorting the GR and LG terminals on the Power Supply Unit.
- Do not apply voltages or connect loads to the Output Units in excess of the maximum switching capacity. Excess voltage or loads may result in burning.
- Do not pull on the cables or bend the cables beyond their natural limit. Doing either of these may break the cables.
- Do not place objects on top of the cables or other wiring lines. Doing so may break the cables.
- Do not use commercially available RS-232C personal computer cables. Always use the special cables listed in this manual or make cables according to manual specifications. Using commercially available cables may damage the external devices or CPU Unit.
- Never connect pin 6 (5-V power supply) on the RS-232C port on the CPU Unit to any device other than an NT-AL001 Link Adapter, CJ1W-CIF11 Converter, and Programmable Terminals (NV3W-M□20L). The external device or the CPU Unit may be damaged.

● Handling

- The Power Supply Unit may possibly be damaged if the entire voltage for a dielectric strength test is applied or shut OFF suddenly using a switch. Use a variable resistor to gradually increase and decrease the voltage.
- Separate the line ground terminal (LG) from the functional ground terminal (GR) on the Power Supply Unit before performing withstand voltage tests or insulation resistance tests. Not doing so may result in burning.
- Make sure that the DIP switches and DM Area are set correctly before starting operation.
- After replacing the CPU Unit, a Special I/O Unit, or a CPU Bus Unit, make sure that the required data for the DM Area, Holding Area, and other memory areas has been transferred to the new Unit before restarting operation.
- Confirm that no adverse effect will occur in the system before attempting any of the following. Not doing so may result in an unexpected operation.
 - Changing the operation mode of the PLC (including the setting of the startup operation mode).
 - Force-setting/force-resetting any bit in memory.

- Changing the present value of any word or any set value in memory.
- Do not attempt to disassemble, repair, or modify any Units. Any attempt to do so may result in malfunction, fire, or electric shock.
- Do not drop the PLC or subject abnormal vibration or shock to it.
- The life of the battery will be reduced if the PLC is left for a period of time without a battery installed and without power supply, and then a battery is installed without turning ON the power supply.
- Replace the battery as soon as a battery error occurs or as soon as the specified battery backup time expires. Be sure to install a replacement battery within two years of the production date shown on the battery's label.
- Before replacing the battery, turn ON power for at least 5 minutes before starting the replacement procedure and complete replacing the battery within 5 minutes of turning OFF the power supply. Memory contents may be corrupted if this precaution is not obeyed.
- If the Battery Error Flag is used in programming the application, confirm system safety even if the system detects a battery error before you replace the battery while the power is ON.
- Do not short the battery terminals or charge, disassemble, heat, or incinerate the battery. Do not subject the battery to strong shocks. Doing any of these may result in leakage, rupture, heat generation, or ignition of the battery. Dispose of any battery that has been dropped on the floor or otherwise subjected to excessive shock. Batteries that have been subjected to shock may leak if they are used.
- UL standards require that only an experienced engineer can replace the battery. Make sure that an experienced engineer is in charge of battery replacement. Follow the procedure for battery replacement given in this manual.
- Dispose of the product and batteries according to local ordinances as they apply.



廢電池請回收

- If the I/O Hold Bit is turned ON, the outputs from the PLC will not be turned OFF and will maintain their previous status when the PLC is switched from RUN or MONITOR mode to PROGRAM mode. Make sure that the external loads will not produce dangerous conditions when this occurs. (When operation stops for a fatal error, including those produced with the FALS(007) instruction, all outputs from Output Unit will be turned OFF and only the internal output status will be maintained.)
- Unexpected operation may result if inappropriate data link tables or parameters are set. Even if appropriate data link tables and parameters have been set, confirm that the controlled system will not be adversely affected before starting or stopping data links.
- Write programs so that any data that is received for data link communications is used only if there are no errors in the CPU Units that are the sources of the data. Use the CPU Unit error information in the status flags to check for errors in the source CPU Units. If there are errors in source CPU Units, they may send incorrect data.
- All CPU Bus Units will be restarted when routing tables are transferred from a Programming Device to the CPU Unit. Restarting these Units is required to read and enable the new routing tables. Confirm that the system will not be adversely affected before transferring the routing tables.
- Tag data links will stop between related nodes while tag data link parameters are being transferred during PLC operation. Confirm that the system will not be adversely affected before transferring the tag data link parameters.
- If there is interference with network communications, output status will depend on the devices that are being used. When using devices with outputs, confirm the operation that will occur when there is interference with communications, and implement safety measures as required.

- When creating an AUTOEXEC.IOM file from a Programming Device (a Programming Console or the CX-Programmer) to automatically transfer data at startup, set the first write address to D20000 and be sure that the size of data written does not exceed the size of the DM Area. When the data file is read from the Memory Card at startup, data will be written in the CPU Unit starting at D20000 even if another address was set when the AUTOEXEC.IOM file was created. Also, if the DM Area is exceeded (which is possible when the CX-Programmer is used), the remaining data will be written to the EM Area.
- The user program and parameter area data in the CJ2 CPU Units are backed up in the built-in flash memory. The BKUP indicator will light on the front of the CPU Unit when the backup operation is in progress. Do not turn OFF the power supply to the CPU Unit when the BKUP indicator is lit. The data will not be backed up if power is turned OFF.
- Check the user program and Unit parameter settings for proper execution before actually running them on the Unit. Not checking the program and parameter settings may result in an unexpected operation.
- When setting a Special I/O Unit or CPU Bus Unit in the I/O tables, carefully check the safety of the devices at the connection target before restarting the Unit.
- Do not turn OFF the power supply to the PLC when reading or writing a Memory Card. Also, do not remove the Memory Card when the BUSY indicator is lit. Doing so may make the Memory Card unusable.
To remove a Memory Card, first press the memory card power supply switch and then wait for the BUSY indicator to go out before removing the Memory Card.
- When restoring data, carefully check that the selected data is the correct data to be restored before executing the restore operation. Depending on the contents of the selected data, the control system may operate unexpectedly after the data is restored.
- Some Special I/O Units and CPU Bus Units operate with parameters stored in the CPU Unit (e.g., words allocated in DM Area, data link tables, or Ethernet settings). Information on restrictions will be displayed in the Information Area in the PLC Backup Tool if there are any restrictions for the selected CPU Bus Unit or Special I/O Unit. Check the restrictions, and then be sure to select both the CPU Unit and the CPU Bus Unit or Special I/O Unit when backing up or restoring data. The control system may operate unexpectedly if the equipment is started with the data backed up or restored without selecting both Units.
- Information on restrictions will be displayed in the Information Area in the PLC Backup Tool if the data to be stored includes a Unit that has restrictions on backup. Check the information on restrictions and take the required countermeasures. The control system may operate unexpectedly when the equipment is operated after the data is restored
- Before restoring data during PLC operation, be sure that there will be no problem if PLC operation stops. If the PLC stops at an unexpected time, the control system may operate unexpectedly.
- Be sure to turn the PLC power supply OFF and then back ON after restoring data. If the power is not reset, the system may not be updated with the restored data, and the control system may operate unexpectedly.
- Data on forced status can be backed up but it cannot be restored. Perform the procedure to force-set or force-reset bits from the CX-Programmer as required before starting operation after restoring data that includes forced status. Depending on the difference in the forced status, the control system may operate unexpectedly.
- If a symbol or memory address (only symbols are allowed for ST programming) is specified for the suffix of an array variable in ladder or ST programming, be sure that the specified element number does not exceed the maximum memory area range.
Specifying an element number that exceeds the maximum range of the memory area specified for the symbol will result accessing data in a different memory area, and may result in unexpected operation.
- If a symbol or address is specified for an offset in a ladder diagram, program so that the memory area of the start address is not exceeded when the offset is specified indirectly using a word address or symbol.
If an indirect specification causes the address to exceed the area of the start address, the system will access data in other area, and unexpected operation may occur.

● External Circuits

- Always turn ON power to the PLC before turning ON power to the control system. If the PLC power supply is turned ON after the control power supply, temporary errors may result in control system signals because the output terminals on DC Output Units and other Units will momentarily turn ON when power is turned ON to the PLC.
- Install external breakers and take other safety measures against short-circuiting in external wiring. Insufficient safety measures against short-circuiting may result in burning.

Operating Environment Precautions

- Follow the instructions in this manual to correctly perform installation.
- Do not operate the control system in the following locations:
 - Locations subject to direct sunlight.
 - Locations subject to temperatures or humidity outside the range specified in the specifications.
 - Locations subject to condensation as the result of severe changes in temperature.
 - Locations subject to corrosive or flammable gases.
 - Locations subject to dust (especially iron dust) or salts.
 - Locations subject to exposure to water, oil, or chemicals.
 - Locations subject to shock or vibration.
- Take appropriate and sufficient countermeasures when installing systems in the following locations:
 - Locations subject to static electricity or other forms of noise.
 - Locations subject to strong electromagnetic fields.
 - Locations subject to possible exposure to radioactivity.
 - Locations close to power supplies.

Regulations and Standards

Conformance to EC Directives

Applicable Directives

- EMC Directives
- Low Voltage Directive

Concepts

● EMC Directives

OMRON devices that comply with EC Directives also conform to the related EMC standards so that they can be more easily built into other devices or the overall machine. The actual products have been checked for conformity to EMC standards (see the following note). Whether the products conform to the standards in the system used by the customer, however, must be checked by the customer.

EMC-related performance of the OMRON devices that comply with EC Directives will vary depending on the configuration, wiring, and other conditions of the equipment or control panel on which the OMRON devices are installed.

The customer must, therefore, perform the final check to confirm that devices and the overall machine conform to EMC standards.

- * Applicable EMC (Electromagnetic Compatibility) standards are as follows:
EMS (Electromagnetic Susceptibility):
EN 61000-6-2
- * EMI (Electromagnetic Interference):
EN 61000-6-4 (Radiated emission: 10-m regulations)

● Low Voltage Directive

Always ensure that devices operating at voltages of 50 to 1,000 VAC and 75 to 1,500 VDC meet the required safety standards for the PLC (EN 61131-2).

● Conformance to EC Directives

The CJ-series PLCs comply with EC Directives. To ensure that the machine or device in which the CJ-series PLC is used complies with EC Directives, the PLC must be installed as follows:

- The CJ-series PLC must be installed within a control panel.
- You must use reinforced insulation or double insulation for the DC power supplies connected to DC Power Supply Units and I/O Units.
- CJ-series PLCs complying with EC Directives also conform to the Common Emission Standard (EN 61000-6-4). Radiated emission characteristics (10-m regulations) may vary depending on the configuration of the control panel used, other devices connected to the control panel, wiring, and other conditions. You must therefore confirm that the overall machine or equipment complies with EC Directives.

Conformance to Shipbuilding Standards

This product conforms to the following shipbuilding standards. Applicability to the shipbuilding standards is based on certain usage conditions. It may not be possible to use the product in some locations. Contact your OMRON representative before attempting to use a PLC on a ship.

Usage Conditions for NK and LR Shipbuilding Standards

● Usage Conditions for Applications Other Than on the Bridge or Deck

- The PLC must be installed in a control panel.
- Gaps in the door to the control panel must be completely filled or covered with gaskets or other material.

● Usage Conditions for Bridge and Deck (Certified Only by NK)

- The PLC must be installed in a control panel.
- Gaps in the door to the control panel must be completely filled or covered with gaskets or other material.
- The following noise filter must be connected to the power supply line.

Noise Filter

Manufacturer	Cosel Co., Ltd.
Model	TAH-06-683

Conformance to UL and CSA Standards

This product complies with applicable UL and CSA standards. The following application conditions were specified for compliance. Refer to Precaution for Compliance with Standards and CSA Standards provided with the product in advance.

Application Conditions for the CJ2M-MD21□

- The temperature inside the control panel must be 50°C or less.
- The following Connector-Terminal Block Conversion Unit and Connecting Cable must be used to wire I/O.
 - Connector-Terminal Block Conversion Unit: XW2B-40G4
 - Connecting Cable: XW2Z-□□□K□
- A power supply that complies with UL Class 2 must be used for the output power supply.

Trademarks

SYSMAC is a registered trademark for Programmable Controllers made by OMRON Corporation.

CX-One is a registered trademark for Programming Software made by OMRON Corporation.

Windows is a registered trademark of Microsoft Corporation.

Other system names and product names in this document are the trademarks or registered trademarks of their respective companies.

Unit Versions of CJ2 CPU Units

Unit Versions and Programming Devices

When using a Pulse I/O Module, use the following unit version of a CJ2M CPU Unit and the following version of the CX-Programmer.

CJ2M CPU Unit	Unit version 2.0 (Built-in Ether-Net/IP section: Unit version 2.0)
CX-Programmer	Ver. 9.12

Refer to the *CJ2 CPU Unit Hardware Manual* (Cat. No. W472) or the *CJ2 CPU Unit Software Manual* (Cat. No. W473) for information on unit versions.

Related Manuals

Manuals related to a PLC built using a CJ-series CJ2 CPU Unit are listed in the following table. Use these manuals for reference.

Manual	Cat. No.	Model	Application	Description
CJ-series CJ2M CPU Unit Pulse I/O Module User's Manual (this manual)	W486	CJ2M-CPU□□ + CJ2M-MD21□	Information on using pulse I/O on CJ2M CPU Units	Provides the following information on the CJ2M CPU Units: <ul style="list-style-type: none"> • Specifications and wiring methods • I/O functions • Quick-response inputs • Interrupt functions • High-speed counters • Pulse outputs • PWM outputs When programming, use this manual together with the <i>Instructions Reference Manual</i> (Cat. No. W474).
CJ-series CJ2 CPU Unit Hardware User's Manual	W472	CJ2H-CPU6□-EIP CJ2H-CPU6□ CJ2M-CPU□□	Hardware specifications for CJ2 CPU Units	Describes the following for CJ2 CPU Units: <ul style="list-style-type: none"> • Overview and features • Basic system configuration • Part nomenclature and functions • Mounting and setting procedure • Remedies for errors Also refer to the <i>Software User's Manual</i> (W473).
CJ-series CJ2 CPU Unit Software User's Manual	W473	CJ2H-CPU6□-EIP CJ2H-CPU6□ CJ2M-CPU□□	Software specifications for CJ2 CPU Units	Describes the following for CJ2 CPU Units: <ul style="list-style-type: none"> • CPU Unit operation • Internal memory • Programming • Settings • Functions built into the CPU Unit Also refer to the <i>Hardware User's Manual</i> (W472).
EtherNet/IP Units Operation Manual	W465	CJ2H-CPU6□-EIP CJ2M-CPU□□ CS1W-EIP21 CJ1W-EIP21	Using the built-in EtherNet/IP port of the CJ2 CPU Unit	Describes the built-in EtherNet/IP port and EtherNet/IP Units. Describes basic settings, tag data links, FINS communications, and other functions.
CS/CJ/NSJ-series Instructions Reference Manual	W474	CJ2H-CPU6□-EIP CJ2H-CPU6□ CJ2M-CPU□□ CS1G/H-CPU□□H CS1G/H-CPU□□-V1 CJ1G/H-CPU□□H CJ1G-CPU□□ CJ1M-CPU□□ NSJ□-□□□□(B)-G5D NSJ□-□□□□(B)-M3D	Information on instructions	Describes each programming instruction in detail. Also refer to the <i>Software User's Manual</i> (W473) when you do programming.

Manual	Cat. No.	Model	Application	Description
CS/CJ/CP/NSJ-series Communications Command Reference Manual	W342	CJ2H-CPU6□-EIP CJ2H-CPU6□ CJ2M-CPU□□ CS1G/H-CPU□□H CS1G/H-CPU□□-V1 CS1D-CPU□□H CS1D-CPU□□S CS1W-SCU□□-V1 CS1W-SCB□□-V1 CJ1H-CPU□□H-R CJ1G/H-CPU□□H CJ1G-CPU□□P CJ1M-CPU□□ CJ1G-CPU□□ CJ1W-SCU□□-V1 CP1H-X□□□□-□ CP1H-XA□□□□-□ CP1H-Y□□□□-□ CP1L-M/L□□□□-□ CP1E-E□□D□-□ CP1E-N□□D□-□ CP1L-M/L□□□□-□□ CP1E-E/N□□D□-□ NSJ□-□□□□(B)-G5D NSJ□-□□□□(B)-M3D	Information on communications for CS/CJ/CP-series CPU Units and NSJ-series Controllers	Describes C-mode commands and FINS commands Refer to this manual for a detailed description of commands for communications with the CPU Unit using C mode commands or FINS commands. Note This manual describes the communications commands that are addressed to CPU Units. The communications path that is used is not relevant and can include any of the following: serial ports on CPU Units, communications ports on Serial Communications Units/Boards, and Communications Units. For communications commands addressed to Special I/O Units or CPU Bus Units, refer to the operation manual for the related Unit.
CX-One Setup Manual	W463	CXONE-AL□□C-V□/AL□□D-V□	Installing software from the CX-One	Provides an overview of the CX-One FA Integrated Tool Package and describes the installation procedure.
CX-Programmer Operation Manual	W446	WS02-CX□□-V□	Support Software for Windows computers	Describes operating procedures for the CX-Programmer. Also refer to the <i>Software User's Manual (W473)</i> and <i>CS/CJ/NSJ-series Instructions Reference Manual (W474)</i> when you do programming.
CX-Programmer Operation Manual Functions Blocks/Structured Text	W447		CX-Programmer operating procedure	
CX-Programmer Operation Manual SFC Programming	W469			
CS/CJ/CP/NSJ-series CX-Simulator Operation Manual	W366	WS02-SIMC1-E	Operating procedures for CX-Simulator Simulation Support Software for Windows computers Using simulation in the CX-Programmer with CX-Programmer version 6.1 or higher	Describes the operating procedures for the CX-Simulator. When you do simulation, also refer to the <i>CX-Programmer Operation Manual (W446)</i> , <i>Software User's Manual (W473)</i> , and <i>CS/CJ/NSJ-series Instructions Reference Manual (W474)</i> .
CS/CJ/CP/NSJ-series CX-Integrator Network Configuration Software Operation Manual	W464	CXONE-AL□□C-V□/CXONE-AL□□D-V□	Network setup and monitoring	Describes the operating procedures for the CX-Integrator.

1

Overview

This section gives an overview of the Pulse I/O Modules for CJ2M CPU Units and the functions of the pulse I/O of the CJ2M CPU Units.

1-1 Pulse I/O Modules	1-2
1-2 Overview of the Functions of CJ2M Pulse I/O	1-4
1-3 Functions of CJ2M Pulse I/O	1-6

1-1 Pulse I/O Modules

A Pulse I/O Module is required as the interface between the CJ2M and external devices when using CJ2M pulse I/O. Up to two Pulse I/O Modules can be connected to the left side of a CJ2M CPU Unit.

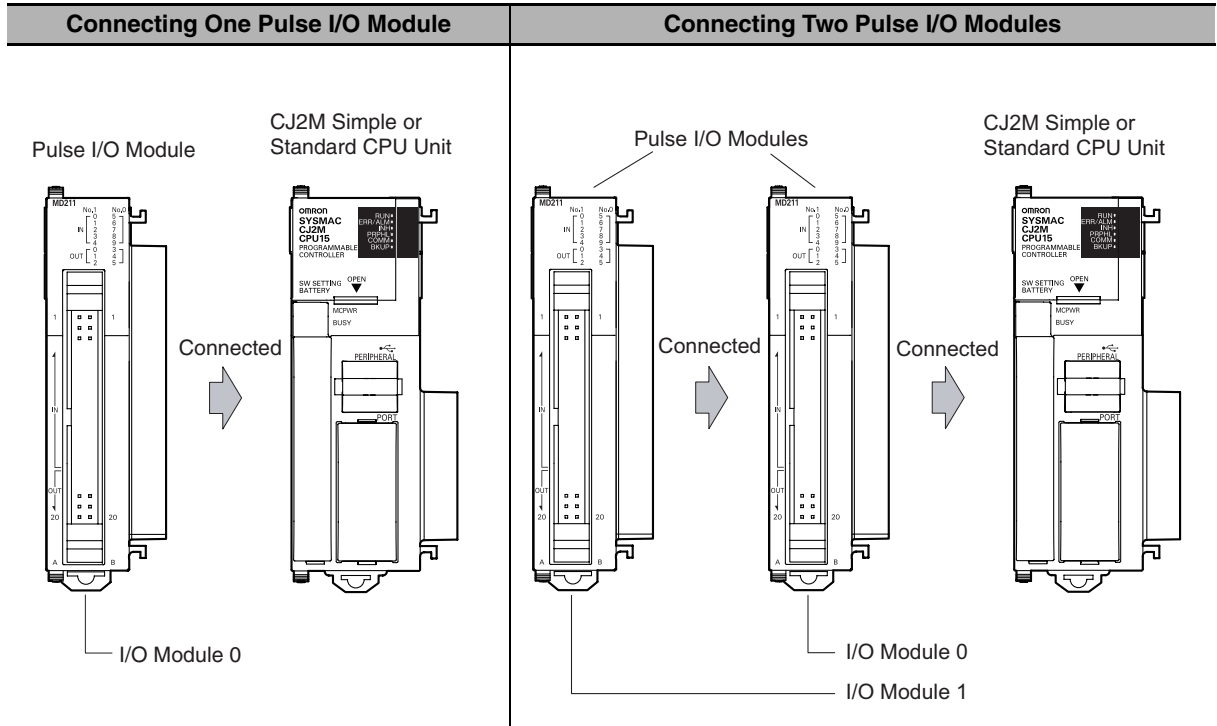

The following models are supported.

Name	Model	Model with transistor outputs	Specifications
Pulse I/O Module	CJ2M-MD211	Sinking outputs	40-pin MIL connectors
	CJ2M-MD212	Sourcing outputs	

Note The connector for the Connecting Cable is not provided with the Pulse I/O Module. Purchase and use a Connector or Connecting Cable (sold separately). Refer to 3-2-3 *Wiring* for details.

Detection of Pulse I/O Modules

- The CJ2M CPU Unit detects the configuration of mounted Pulse I/O Modules each time the power supply is turned ON. An error will not occur even if the number or models of the mounted Pulse I/O Modules are different from the last time the PLC was operated.
- A fatal error (too many I/O points) will occur and the CPU Unit will not operate if three or more Pulse I/O Modules are mounted.

● Configuration Example of a CJ2M System with a Pulse I/O Module

Connecting One Servo Drive

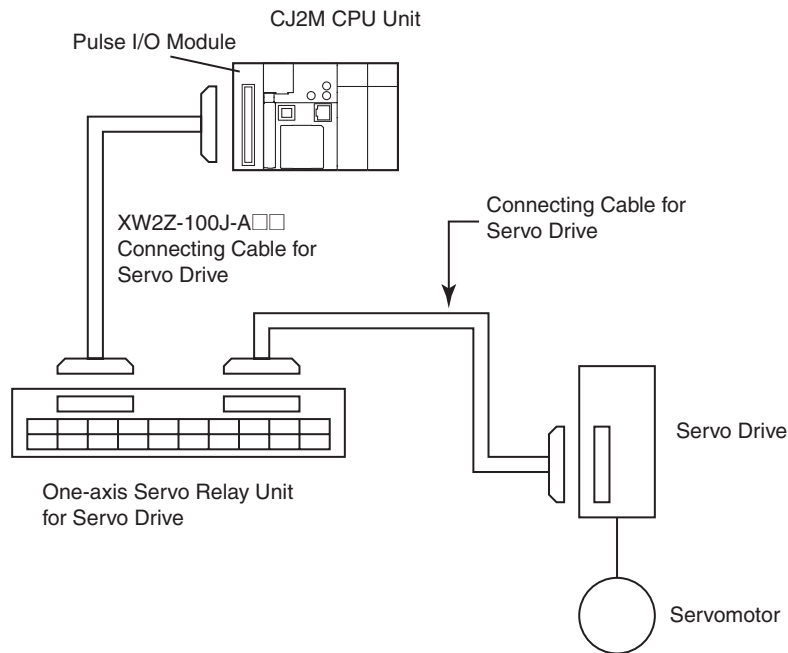

Additional Information

- Pulse I/O Modules can be connected only to CJ2M CPU Units. They cannot be used with CJ2H CPU Units.
- The pin arrangement of the I/O connected on the CJ2M-MD211 (sinking outputs) is compatible with the built-in I/O connector on the CJ1M-CPU2 CPU Unit.

1-2 Overview of the Functions of CJ2M Pulse I/O

The following functions of the pulse I/O of the CJ2M can be used by installing a Pulse I/O Module. Select which function to use for each input and output in the PLC Setup.

Functions of Normal I/O

The inputs and outputs on the Pulse I/O Module can be used as normal inputs and normal outputs. (Each Pulse I/O Module provides up to 10 inputs and 6 outputs.) The input time constant can be set to 0 ms (no filter), 0.5 ms, 1 ms, 2 ms, 4 ms, 8 ms, 16 ms, or 32 ms. The same setting is used for all 20 inputs. Chattering and the effects of external noise can be reduced by increasing the input time constant.

Quick-response Inputs

By setting an input on the Pulse I/O Module to quick-response input operation, inputs with signal widths as small as 30 μ s can be read with certainty regardless of the cycle time. Up to four quick-response inputs can be used for each Pulse I/O Module (eight for the entire CJ2M PLC).

Interrupt Inputs

An interrupt task can be started when an input on the Pulse I/O Module turns ON or OFF (Direct Mode). Alternatively, the rising or falling edge of the inputs can be counted. When the count reaches a specified value, an interrupt task can be started. This is called Counter Mode. Up to four interrupt inputs can be used for each Pulse I/O Module (eight for the entire CJ2M PLC).

High-speed Counters

A rotary encoder can be connected to the Pulse I/O Module input to accept differential phase or single-phase high-speed pulse counter inputs.

High-speed counter inputs (differential phase: 50 kHz, single-phase: 100 kHz) for up to 2 axes can be used for each Pulse I/O Module (up to 4 axes for the entire CJ2M PLC).

- **Use the Linear Mode or Ring Mode for the Counting Mode**

The maximum value of the ring counter can be changed during operation using the MODE CONTROL (INI(880)) instruction.

- **Start Interrupt Tasks Using Target Value Comparison or Range Comparison for High-speed Processing**

Interrupt tasks can be started when the PV reaches a target value for target value comparison, or when it enters a specified range for range comparison.

- **Frequency Measurement**

The input pulse frequency can be measured by executing the HIGH-SPEED COUNTER PV READ (PRV(881)) instruction. (Applicable only to high-speed counter 0.) It is possible to convert the frequency to a rotational speed by executing the COUNTER FREQUENCY CONVERT (PRV2(883)) instruction.

- **Maintain or Refresh (Selectable) High-speed Counter PVs**

The High-speed Counter Gate Bit can be turned ON/OFF from the ladder program to select whether the high-speed counter PVs will be maintained or refreshed.

Pulse Outputs

Fixed duty ratio pulse outputs can be output from the Pulse I/O Module outputs and used to perform position or speed control with a Servo Drive or a stepping motor that accepts pulse inputs. Each Pulse I/O Module provides 100-kHz pulse outputs for up to 2 axes (up to 4 axes for entire CJ2M PLC).

- **Trapezoidal or S-curve Acceleration and Deceleration for Positioning**

Trapezoidal or S-curve acceleration and deceleration can be used for position control using the PULSE OUTPUT (PLS2(887)) instruction.

- **Triangular Control for Pulse Outputs**

If the target frequency cannot be reached when the setting is changed with a PLS2(887) or ACC(888) instruction, triangular control will be performed. If the target position is exceeded using the specified deceleration ratio, the deceleration ratio will be automatically corrected.

- **Jogging Can Be Performed**

Jogging can be performed by executing the SPED(885) or ACC(888) instruction.

- **Pulse Output Frequency Tracing**

Changes in the pulse output frequency can be checked graphically by using the CX-Programmer's Data Trace Window.

- **Easy Interrupt Feeding**

An interrupt input can be used as a trigger to switch from speed control to position control and output the specified number of pulses, then decelerate to a stop using the INTERRUPT FEEDING (IFEED(892)) instruction.

- **Origin Searches and Origin Returns Can Be Performed Using the ORIGIN SEARCH Instruction**

An accurate origin search combining all I/O signals can be executed with a single instruction. It is also possible to move directly to an established origin using the ORIGIN SEARCH (ORG(889)) instruction. It is also possible to perform origin returns by directly moving to a defined origin.

The origin search and origin return settings can be changed during operation using the MODE CONTROL (INI(880)) instruction.

PWM Outputs

Lighting and power control can be performed by outputting variable duty ratio pulse (PWM) output signals from the outputs of the Pulse I/O Module.

Up to two PWM outputs can be used for each Pulse I/O Module (four for the entire CJ2M PLC).

1-3 Functions of CJ2M Pulse I/O

The following functions of the CJ2M can be used by installing a Pulse I/O Module.



Additional Information

For information on installing Pulse I/O Modules, the number of Blocks and their positions, indicators, part names, part functions, and the external dimensions, refer to the *CJ2 CPU Unit Hardware User's Manual* (Cat. No. W472).

Item		Function	Reference
Inputs	Normal inputs	The status of input signals for normal I/O is read and stored in I/O memory during the I/O refresh period.	4-1 Normal Inputs
	Interrupt inputs in Direct Mode	The input signal triggers an interrupt task when it turns ON or OFF.	6-2 Interrupt Inputs
	Interrupt inputs in Counter Mode	The number of ON transitions or OFF transitions in the input signal is counted and an interrupt task is started when the specified count is reached.	
	High-speed counter inputs	High-speed counter inputs can be used to count high-speed pulse signals. Interrupt tasks can also be started.	Section 7 High-speed Counters
Outputs	Normal outputs	Outputs according to the content of the I/O memory and refresh timing.	4-2 Normal Outputs
	Pulse outputs	The specified number of pulses are output at a fixed duty ratio (50%) at the specified frequency.	Section 8 Pulse Outputs
	PWM outputs (variable duty ratio pulse outputs)	Pulse are output at the specified duty ratio.	Section 9 PWM Outputs
Defining the origin		Defines the machine origin by actually executing pulse output based on the pattern specified in the origin search parameters, using the origin proximity input and origin input signals as conditions. (Inputs and outputs are used in combination.)	8-5 Defining the Origin

2

I/O Application Procedures and Function Allocations

This section describes the procedures for using the I/O functions of the Pulse I/O Module and how to allocate functions to the I/O.

2-1	Pulse I/O Module Application Procedure	2-2
2-2	Allocating I/O Functions	2-4
2-2-1	Specifying the Functions to Use	2-4
2-2-2	Selecting Functions in the PLC Setup	2-4
2-2-3	Allocating Functions to Input Terminals	2-5
2-2-4	Allocating Functions to Output Terminals	2-7
2-3	PLC Setup	2-8
2-3-1	Normal Input Operation Setting	2-9
2-3-2	Interrupt Input and Quick-response Input Detailed Settings	2-9
2-3-3	High-speed Counter Settings	2-10
2-3-4	Pulse Output and Origin Search Settings	2-11

2-1 Pulse I/O Module Application Procedure

The following procedure shows how to use the I/O functions of the Pulse I/O Module.

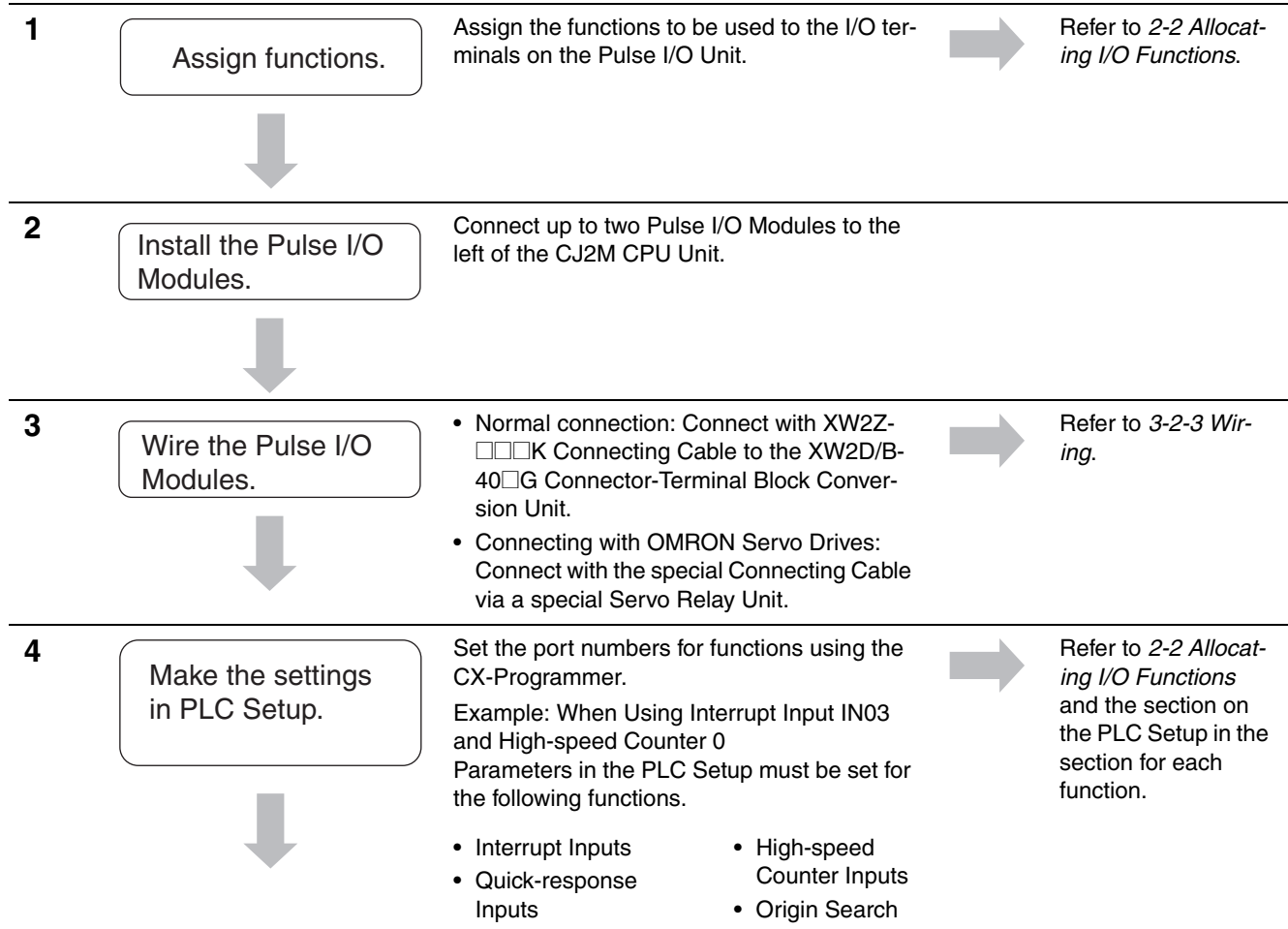

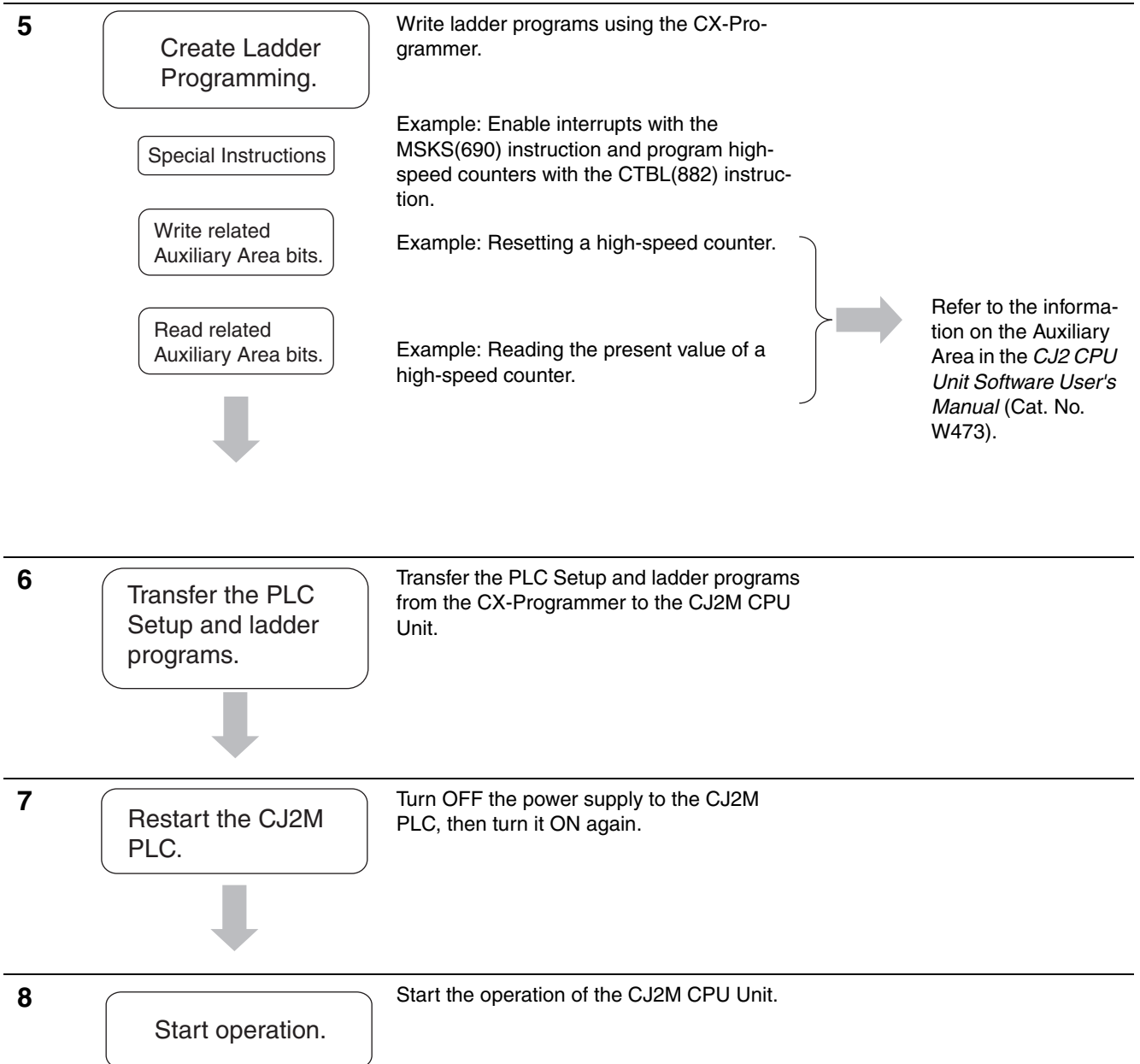

2-2 Allocating I/O Functions

2-2-1 Specifying the Functions to Use

Each of the Pulse I/O Module inputs and outputs are used for one of the I/O functions.

Some I/O terminals may support more than one function. However, only one function can be assigned to each terminal. Specify the input functions in the PLC Setup from the CX-Programmer, and specify the output functions in PLC Setup and programming instructions.

Multiple terminals are sometimes used in combination depending on the function, so some functions cannot be combined. Allocate functions to be used to terminals in the CX-Programmer's PLC Setup. The CX-Programmer automatically displays the combination of terminals that can be selected so that there is no need to be concerned about allocating more than one function to the same terminal.

To see which functions can be allocated to which I/O terminals, refer to 2-2-3 *Allocating Functions to Input Terminals* and 2-2-4 *Allocating Functions to Output Terminals*.

2-2-2 Selecting Functions in the PLC Setup

- Inputs can be selected on the I/O Module Tab Page.

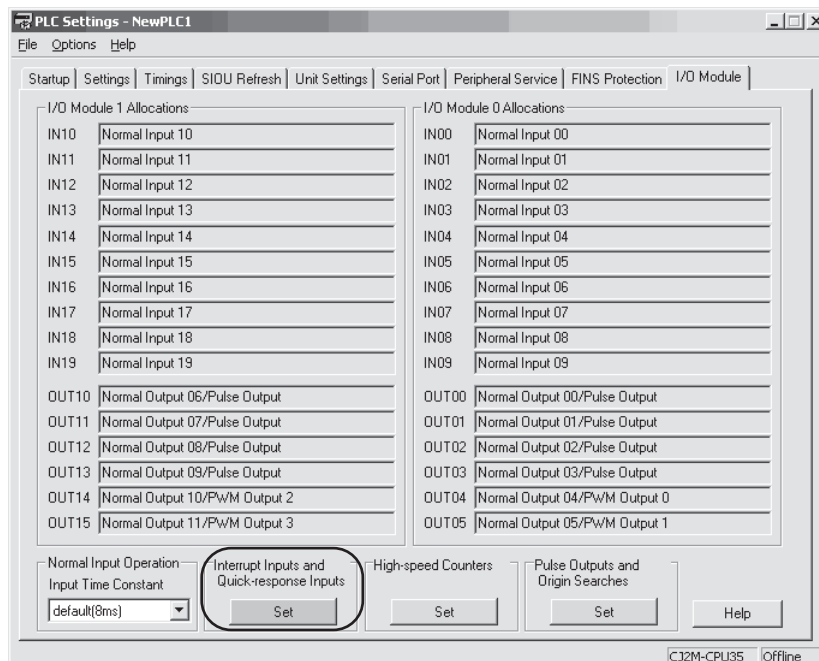

Click the **Set** Button in the Interrupt Inputs and Quick-response Inputs Area to display a dialog box to allocate functions to interrupt inputs and quick-response inputs.

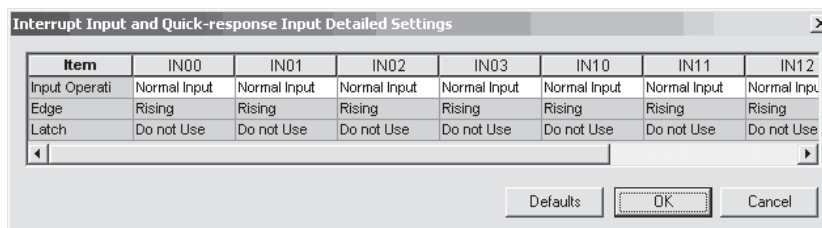

The order of preference for allocating functions to inputs is as follows:

Origin Search > High-speed Counter (Phase Z/Reset) > Normal Inputs, Interrupt Inputs, and Quick-response Inputs

2-2-3 Allocating Functions to Input Terminals

Allocating Functions to Input Terminals

Input terminals are allocated functions by setting parameters in the PLC Setup. Do not allocate more than one function to the same input terminal.

Pulse I/O Module No.	Input terminal symbol	Bit address	Normal inputs	Interrupt inputs* (Direct Mode/Counter Mode)	Quick-response inputs	High-speed counter inputs	Pulse output origin search inputs
0 (on the right)	IN00	CIO 2960.00	Normal input 0	Interrupt input 0	Quick-response input 0	---	Pulse output 0 origin input signal
	IN01	CIO 2960.01	Normal input 1	Interrupt input 1	Quick-response input 1	---	Pulse output 0 origin proximity input signal
	IN02	CIO 2960.02	Normal input 2	Interrupt input 2	Quick-response input 2	Counter 1 phase Z or reset	Pulse output 1 origin input signal
	IN03	CIO 2960.03	Normal input 3	Interrupt input 3	Quick-response input 3	Counter 0 phase Z or reset	Pulse output 1 origin proximity input signal
	IN04	CIO 2960.04	Normal input 4	---	---	---	Pulse output 0 positioning completed signal
	IN05	CIO 2960.05	Normal input 5	---	---	---	Pulse output 1 positioning completed signal
	IN06	CIO 2960.06	Normal input 6	---	---	Counter 1 phase A, increment, or count input	---
	IN07	CIO 2960.07	Normal input 7	---	---	Counter 1 phase B, decrement, or direction input	---
	IN08	CIO 2960.08	Normal input 8	---	---	Counter 0 phase A, increment, or count input	---
	IN09	CIO 2960.09	Normal input 9	---	---	Counter 0 phase B, decrement, or direction input	---

Pulse I/O Module No.	Input terminal symbol	Bit address	Normal inputs	Interrupt inputs* (Direct Mode/Counter Mode)	Quick-response inputs	High-speed counter inputs	Pulse output origin search inputs
1 (on the left)	IN10	CIO 2962.00	Normal input 10	Interrupt input 4	Quick-response input 4	---	Pulse output 2 origin input signal
	IN11	CIO 2962.01	Normal input 11	Interrupt input 5	Quick-response input 5	---	Pulse output 2 origin proximity input signal
	IN12	CIO 2962.02	Normal input 12	Interrupt input 6	Quick-response input 6	Counter 3 phase Z or reset	Pulse output 3 origin input signal
	IN13	CIO 2962.03	Normal input 13	Interrupt input 7	Quick-response input 7	Counter 2 phase Z or reset	Pulse output 3 origin proximity input signal
	IN14	CIO 2962.04	Normal input 14	---	---	---	Pulse output 2 positioning completed signal
	IN15	CIO 2962.05	Normal input 15	---	---	---	Pulse output 3 positioning completed signal
	IN16	CIO 2962.06	Normal input 16	---	---	Counter 3 phase A, increment, or count input	---
	IN17	CIO 2962.07	Normal input 17	---	---	Counter 3 phase B, decrement, or direction input	---
	IN18	CIO 2962.08	Normal input 18	---	---	Counter 2 phase A, increment, or count input	---
	IN19	CIO 2962.09	Normal input 19	---	---	Counter 2 phase B, decrement, or direction input	---

* Only specific pairs of interrupt inputs and pulse outputs can be used together when using interrupt inputs with the INTERRUPT FEEDING (IFEED(892)) instruction. For details, refer to 8-4-4 INTERRUPT FEEDING Instruction: IFEED(892).

Prohibition of Duplicated Use of Input Terminal Numbers

The bits 00 to 09 of CIO 2960 and CIO 2962 are used for interrupt inputs, quick-response inputs, high-speed counters, origin searches, and normal inputs. The same input terminal can be used for only one of these functions. For example, if quick-response input 2 is used, then input terminal 02 cannot be used for normal input 2, interrupt input 2, counter 1 phase Z/reset, or pulse output 1 origin input signal.

2-2-4 Allocating Functions to Output Terminals

Allocating Functions to Output Terminals

Functions are assigned to output terminals when an instruction is executed for an output bit. (The instructions that can be used include OUT, ORG(889), and PWM(891).) If the origin search operation is set to mode 1 or mode 2 in the PLC Setup, PWM outputs cannot be used for the output terminals that are used for error counter reset outputs.

Pulse I/O Module No.	Output terminal symbol	Bit address	Normal outputs	Pulse outputs*			PWM output
				CW/CCW outputs	Pulse + direction outputs	Origin search output	
0 (on the right)	OUT00	CIO 2961.00	Normal output 0	CW pulse output 0	Pulse output 0	---	---
	OUT01	CIO 2961.01	Normal output 1	CCW pulse output 0	Pulse output 1	---	---
	OUT02	CIO 2961.02	Normal output 2	CW pulse output 1	Direction output 0	---	---
	OUT03	CIO 2961.03	Normal output 3	CCW pulse output 1	Direction output 1	---	---
	OUT04	CIO 2961.04	Normal output 4	---	---	Pulse output 0 error counter reset output	PWM output 0
	OUT05	CIO 2961.05	Normal output 5	---	---	Pulse output 1 error counter reset output	PWM output 1
1 (on the left)	OUT10	CIO 2963.00	Normal output 6	CW pulse output 2	Pulse output 2	---	---
	OUT11	CIO 2963.01	Normal output 7	CCW pulse output 2	Pulse output 3	---	---
	OUT12	CIO 2963.02	Normal output 8	CW pulse output 3	Direction output 2	---	---
	OUT13	CIO 2963.03	Normal output 9	CCW pulse output 3	Direction output 3	---	---
	OUT14	CIO 2963.04	Normal output 10	---	---	Pulse output 2 error counter reset output	PWM output 2
	OUT15	CIO 2963.05	Normal output 11	---	---	Pulse output 3 error counter reset output	PWM output 3

* The pulse output method is specified with an operand in the Pulse Output Instruction.

2-3 PLC Setup

The following dialog box will be displayed when the I/O Module Tab Page is opened in the PLC Setup.

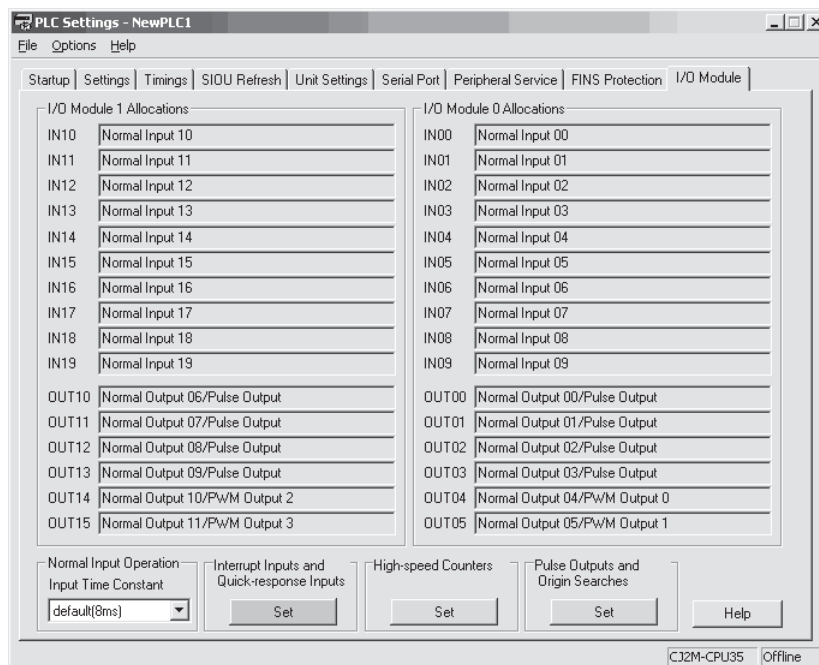

I/O Module 0 Allocations and I/O Module 1 Allocations

The current settings of the I/O terminals on the Pulse I/O Modules are displayed here. Settings made on the dialog boxes that are accessed from this dialog box are shown here so that you can see the current I/O terminal functions settings.

Normal Input Operation Setting

The input constant is set here.

Interrupt Inputs and Quick-response Inputs

The interrupt inputs and quick-response inputs are set here.

High-speed Counters

The functions and operating parameters of the high-speed counters are set here.

Pulse Outputs and Origin Searches

The functions and operating parameters of pulse outputs and the origin search function are set here.

2-3-1 Normal Input Operation Setting

Parameter	Setting	Default	Description	Related Auxiliary Area words and bits	Update timing in CPU Unit
Input Time Constant	<ul style="list-style-type: none"> Default (8 ms) No filter 0.5 ms 1 ms 2 ms 4 ms 8 ms 16 ms 32 ms 	Default (8 ms)	Set the input time constant for normal inputs IN00 to IN19. Note The input constant is ignored for input terminals that are set for interrupt inputs, quick-response inputs, and high-speed counters.	---	Refreshed when power is turned ON.

2-3-2 Interrupt Input and Quick-response Input Detailed Settings

The following dialog box will be displayed if the **Set** Button in the Interrupt Inputs and Quick-response Inputs Area of the I/O Module Tab Page in the PLC Setting Dialog Box. Items that cannot be set will be grayed out. The items that are grayed out can be set if the required Input Operation is set.

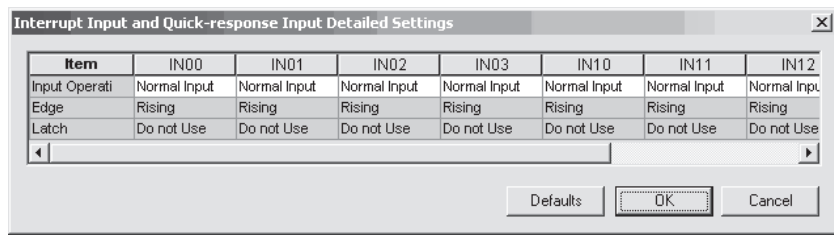

Parameter	Setting	Default	Description	Related Auxiliary Area words and bits	Update timing in CPU Unit
Input Operation	<ul style="list-style-type: none"> Normal Input Quick-response Input Interrupt Input 	Normal Input	Set the function of the internal input.*	---	Refreshed when power is turned ON.
Edge	<ul style="list-style-type: none"> Rising Edge Falling Edge 	Rising Edge	This setting is valid only when the input is set to Interrupt Input. Set whether an interrupt will occur when the input turns ON or OFF.	---	Refreshed when operation is started.
Latch	<ul style="list-style-type: none"> Do not Use Pulse Output 0 Pulse Output 1 Pulse Output 2 Pulse Output 3 High-speed Counter 0 High-speed Counter 1 High-speed Counter 2 High-speed Counter 3 	Do not Use	This setting is valid only when the input is set to Interrupt Input. Select the item to latch when using the software latch for the input for a pulse output/high-speed counter.	Latched PV: A10144 to A10159	Refreshed when power is turned ON.

* Only specific pairs of interrupt inputs and pulse outputs can be used together when using interrupt inputs with the INTERRUPT FEEDING (IFEEED(892))) instruction. For details, refer to 8-4-4 INTERRUPT FEEDING Instruction: IFEEED(892).

2-3-3 High-speed Counter Settings

The following dialog box will be displayed if the **Set** Button is clicked in the High-speed Counters Area of the I/O Module Tab Page in the PLC Setting Dialog Box. Items that cannot be set will be grayed out. The items that are grayed out can be set if the required Counter Setting and Counting Mode are set.

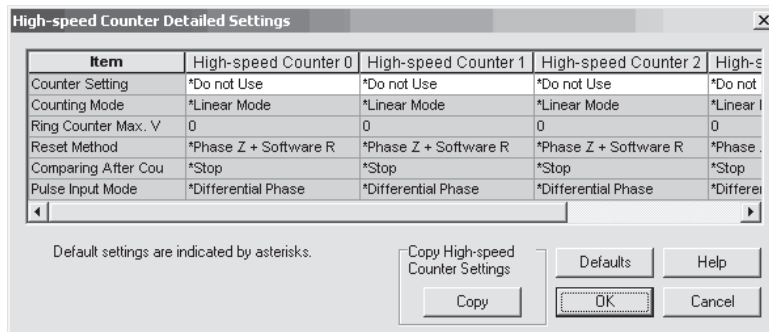

Parameter	Setting	Default	Description	Related Auxiliary Area words and bits	Update timing in CPU Unit
Counter Setting	<ul style="list-style-type: none"> Not Use Input pulse frequency (60 kHz max.) Input pulse frequency (100 kHz max.) 	Not Use	Set whether to use the high-speed counter. When using the high-speed counter, set the upper limit of the input frequency. Note The frequency of the noise filter will change.	---	Refreshed when power is turned ON.
Counting Mode	<ul style="list-style-type: none"> Linear mode Ring mode 	Linear mode	Set whether to use the counter as a linear counter or a ring counter. *This setting is valid only when using the high-speed counter is enabled.	---	Refreshed when power is turned ON or operation is started.
Ring Counter Max. Value	0 to 4,294,967,295	0	Set the maximum value of the ring counter. The PV of the counter will return to 0 when this value is exceeded. *This setting is valid only when using the high-speed counter is enabled and it is set to Ring mode. *If 0 is set, the maximum value of the counter will be 4,294,967,295.	Ring counter maximum value: A10136 to A10143	Refreshed when power is turned ON or operation is started.
Reset Method	<ul style="list-style-type: none"> Z phase, software reset Software reset 	Z phase, software reset	Set the reset method for the PV of the high-speed counter. *This setting is valid only when using the high-speed counter is enabled.	Reset Bits: A531.00 A531.01 A531.02 A531.03	Refreshed when power is turned ON.
Comparing After Counter Reset	<ul style="list-style-type: none"> Stop Continue 	Stop	Set whether to stop the comparison operation or continue it when the counter is reset. *This setting is valid only when using the high-speed counter is enabled.	Comparison In-progress Flags: A274.08 A275.08 A320.08 A321.08	Refreshed when power is turned ON.
Pulse Input Mode	<ul style="list-style-type: none"> Differential Phase Pulse + Direction Up/Down pulses Increment pulse 	Differential Phase	Set the counting method for the high-speed counter. *This setting is valid only when using the high-speed counter is enabled.	---	Refreshed when power is turned ON.

The settings for one high-speed counter can be copied to another high-speed counter. Use the following procedure to copy the settings.

1. Click the **Copy High-speed Counter Settings** Button in the High-speed Counter Detailed Settings Dialog Box.
The Copy High-speed Counter Settings Dialog Box will be displayed.
2. Select a high-speed counter to be copied in the box in the Copy Source Area and select another high-speed counter in the Copy Destination Area.

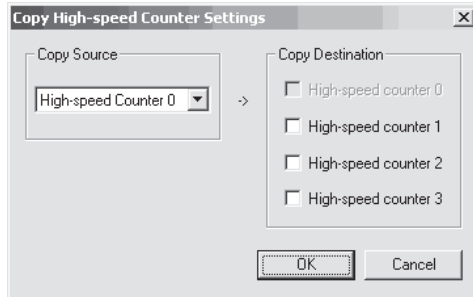

3. Click the **OK** Button.
The settings in the High-speed Counter Detailed Settings Dialog Box will be updated.

To initialize the settings of the high-speed counters, click the **Defaults** Button in the High-speed Counter Detailed Settings Dialog Box.

2-3-4 Pulse Output and Origin Search Settings

The following dialog box will be displayed if the **Set** Button in the Pulse Outputs and Origin Searches Area is selected from the I/O Module Tab Page in the PLC Setting Dialog Box. Items that cannot be set will be grayed out. The items that are grayed out can be set if the required Origin Search Setting and Operation Mode are set.

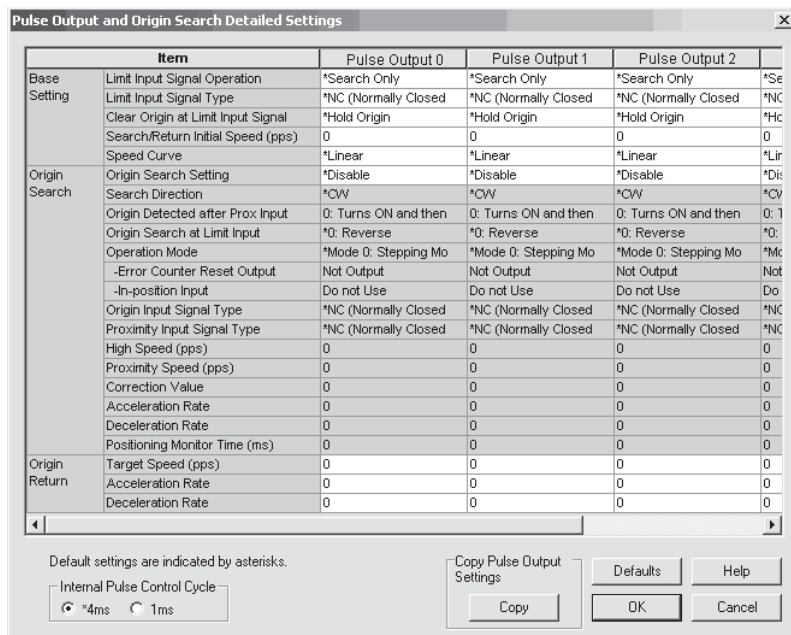

Parameter	Setting	Default	Description	Related Auxiliary Area words and bits	Update timing in CPU Unit
Internal Pulse Control Cycle	<ul style="list-style-type: none"> 4 ms 1 ms 	4 ms	<p>Set the control frequency of the pulse output.</p> <p>This setting affects the response to speed changes when accelerating or decelerating and to change instructions. If 1 ms is set, acceleration and deceleration will be performed in 1-ms increments, providing a faster response for change instructions for pulse outputs when pulses are being output.</p> <p>*Acceleration and deceleration rates are set in 4-ms increments, but internal processing is performed in 1-ms increments.</p>	---	Refreshed when operation is started.

The following operation will be performed for the HUNDRED-MS TIMER (TIM/TIMX(550)), TEN-MS TIMER (TIMH(015)/TIMHX(551)), and ONE-MS TIMER (TMHH(540)/TMHHX(552)) instructions if the pulse control cycle is set to 1 ms.

- An error of up to one cycle time will occur in the timer PV accuracy.
- The timers will not operate correctly if the cycle time exceeds 100 ms.
- If the instructions above are in a task that is stopped or is not executed because it is jumped by a JMP(004), CJMP(510), or CJP(511) instruction, the timer will not operate correctly.

● **Base Settings**

Parameter	Setting	Default	Description	Related Auxiliary Area words and bits	Update timing in CPU Unit
Limit Input Signal Operation	<ul style="list-style-type: none"> Search Only Always 	Search Only	Set whether to enable the CW/CCW limit input signals all the time or only for origin searches.	CW Limit Input Signal Flags: A540.08 A541.08 A542.08 A543.08	Refreshed when operation is started.
Limit Input Signal Type	<ul style="list-style-type: none"> NC (Normally Closed) NO (Normally Open) 	NC (Normally Closed)	Set the contact form for the origin input signal.	CCW Limit Input Signal Flags: A540.09 A541.09 A542.09 A543.09	Refreshed when operation is started.
Clear Origin at Limit Input Signal	<ul style="list-style-type: none"> Hold Origin Clear Origin 	Hold Origin	Set whether to hold or clear the origin when the CW or CCW limit input is received.	No-origin Flags: A280.05 A281.05 A326.05 A327.05	Refreshed when operation is started.
Search/Return Initial Speed (pps)	0 to 100,000	0	Set the starting speed when performing an origin search or origin return.	---	Refreshed when operation is started.
Speed Curve	<ul style="list-style-type: none"> Linear S-curve 	Linear	<p>Set the profile for acceleration/deceleration for pulse outputs with acceleration/deceleration.</p> <p>*This setting is used for acceleration/deceleration for all ports.</p>	---	Refreshed when operation is started.

Origin Search

Parameter	Setting	Default	Description	Related Auxiliary Area words and bits	Update timing in CPU Unit
Origin Search Setting	<ul style="list-style-type: none"> Disable Enable 	Disable	Set whether to use origin searches.	---	Refreshed when power is turned ON.
Search Direction	<ul style="list-style-type: none"> CW CCW 	CW	Set the direction in which to detect signals for origin searches. *This setting is valid only when the origin search function is enabled.	---	Refreshed when operation is started.
Origin Detected after Prox Input	<ul style="list-style-type: none"> 0: Turns ON and then OFF 1: Turns ON 2: Proximity Input Not Used 	0: Turns ON and then OFF	Set the timing for detecting the origin during origin searches. *This setting is valid only when the origin search function is enabled.	---	Refreshed when power is turned ON.
Origin Search at Limit Input	<ul style="list-style-type: none"> 0: Reverse 1: Stop with Error 	0: Reverse	Set the operation to perform when a CW/CCW limit input is received during an origin search. *This setting is valid only when the origin search function is enabled.	---	Refreshed when operation is started.
Operation Mode	<ul style="list-style-type: none"> Mode 0: Stepping Motor Mode 1: Servomotor Mode 2: Servomotor with INP 	Mode 0: Stepping Motor	Set the type of motor drive to use. This setting affects the signals that are used for origin searches and positioning. *This setting is valid only when the origin search function is enabled.	---	Refreshed when operation is started.
Origin Input Signal Type	<ul style="list-style-type: none"> NC (Normally Closed) NO (Normally Open) 	NC (Normally Closed)	Set the contact form for the origin input signal. *This setting is valid only when the origin search function is enabled.	---	Refreshed when operation is started.
Proximity Input Signal Type	<ul style="list-style-type: none"> NC (Normally Closed) NO (Normally Open) 	NC (Normally Closed)	Set the contact form for the proximity input signal. *This setting is valid only when the origin search function is enabled.	---	Refreshed when operation is started.
High Speed (pps)	1 to 100,000 pps	0 pps	Set to speed to use in origin searches until the proximity input signal is received. *This setting is valid only when the origin search function is enabled.	---	Refreshed when operation is started.
Proximity Speed (pps)	1 to 100,000 pps	0 pps	Set to speed to use in origin searches until the origin input signal is received. *This setting is valid only when the origin search function is enabled.	---	Refreshed when operation is started.
Correction Value	-2,147,483,648 to +2,147,483,647	0	Set the correction to apply after detecting the origin input signal. *This setting is valid only when the origin search function is enabled.	---	Refreshed when operation is started.

Parameter	Setting	Default	Description	Related Auxiliary Area words and bits	Update timing in CPU Unit
Acceleration Rate	1 to 65,535	0	Set the acceleration rate in pps per 4 ms for accelerating during origin searches. *This setting is valid only when the origin search function is enabled.	---	Refreshed when operation is started.
Deceleration Rate	1 to 65,535	0	Set the deceleration rate in pps per 4 ms for decelerating during origin searches. *This setting is valid only when the origin search function is enabled.	---	Refreshed when operation is started.
Positioning Monitor Time (ms)	0 to 9,999 ms	0	Set the time to monitor for the positioning completed signal after pulse output has been completed. A Positioning Timeout Error (error code 0300) will occur if the positioning completed signal is not received within the positioning monitor time. *This setting is valid only when the origin search function is enabled and operation mode 2 is set.	Pulse Output Stopped Error Flags: A280.07 A281.07 A326.07 A327.07	Refreshed when operation is started.

Origin Return

Parameter	Setting	Default	Description	Related Auxiliary Area words and bits	Update timing in CPU Unit
Target Speed (pps)	1 to 100,000 pps	0 pps	Set the operating speed for origin returns.	---	Refreshed when operation is started.
Acceleration Rate	1 to 65,535	0	Set the acceleration rate in pps per 4 ms for accelerating during origin returns.	---	Refreshed when operation is started.
Deceleration Rate	1 to 65,535	0	Set the deceleration rate in pps per 4 ms for decelerating during origin returns.	---	Refreshed when operation is started.

The settings for one pulse output can be copied to another pulse output.

Use the following procedure to copy the settings.

1. Click the **Copy Pulse Output Settings** Button in the Pulse Output and Origin Search Detailed Settings Dialog Box.
The Copy Pulse Output Settings Dialog Box will be displayed.
2. Select the pulse output to be copied in the box in the Copy Source Area and select another pulse output in the Copy Destination Area.

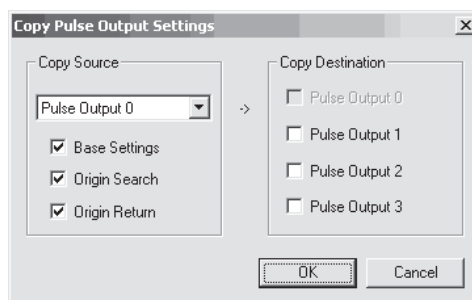

3. Click the **OK** Button.
The settings in the Pulse Output and Origin Search Detailed Settings Dialog Box will be updated.

To initialize the settings of the pulse outputs, click the **Defaults** Button in the Pulse Output and Origin Search Detailed Settings Dialog Box.

3

I/O Specifications and Wiring for Pulse I/O Modules

This section gives the I/O specifications and describes the wiring of the Pulse I/O Modules.

3-1	I/O Specifications	3-2
3-1-1	Input Specifications	3-2
3-1-2	Output Specifications for Sinking Transistor Outputs	3-4
3-1-3	Output Specifications for Sourcing Transistor Outputs	3-5
3-2	Wiring	3-7
3-2-1	Connector Pin Allocations	3-7
3-2-2	I/O Circuit Configurations	3-8
3-2-3	Wiring	3-8

3-1 I/O Specifications

3-1-1 Input Specifications

● Normal Inputs

Inputs	IN00 to IN05 and IN10 to IN15	IN06 to IN09 and IN16 to IN19	IN00 to IN05 and IN10 to IN15	IN06 to IN09 and IN16 to IN19
Input form	24-VDC input		Line driver inputs	
Input current	6.0 mA typical	5.5 mA typical	13 mA typical	10 mA typical
Input voltage range	24 VDC +10%/–15%		RS-422A line driver AM26LS31 or equivalent *1	
Input impedance	3.6 k Ω	4.0 k Ω	---	
Number of circuits	1 common, 1 circuit			
ON voltage/current	17.4 VDC min., 3 mA min.		---	
OFF voltage/current	1 mA max. at 5 VDC max.		---	
ON response time	8 ms max. (The input time constant can be set to 0, 0.5, 1, 2, 4, 8, 16, or 32 ms.)*2			
OFF response time	8 ms max. (The input time constant can be set to 0, 0.5, 1, 2, 4, 8, 16, or 32 ms.)*2			

*1 The power supply voltage on the line driver side is 5 V \pm 5%.

*2 The input time constant can be set in the PLC Setup. When it is set to 0 ms, the delay due to internal components results in an ON delay of 30 μ s max. for IN00 to IN05 and IN10 to IN15 (2 μ s max. for IN06 to IN09 and IN16 to IN19) and an OFF delay of 150 μ s max. for IN00 to IN05 and IN10 to IN15 (2 μ s max. for IN06 to IN09 and IN16 to IN19).

● Interrupt Input and Quick-response Input Specifications (IN00 to IN03 and IN10 to IN13)

Item	Specifications
ON response time	30 μ s max.
OFF response time	150 μ s max.
Response pulse	<p>The diagram shows a digital signal pulse. The signal is initially at a low level labeled 'OFF'. It then transitions to a high level labeled 'ON'. A horizontal double-headed arrow above the pulse indicates a minimum pulse width of 30 μs. After the pulse ends, the signal returns to the 'OFF' level. Another horizontal double-headed arrow above the signal indicates a minimum interval of 150 μs between the end of one pulse and the start of the next.</p>

● High-speed Counter Input Specifications (IN06 to IN09 and IN16 to IN19)

	24-VDC input	Line driver input
Set to 60 kHz	<p>Phase-A/Phase-B encoder input, Single-phase 60-kHz pulse input with 50% duty ratio</p> <p>Rise time and fall time: 3.0 μs max. 16.6 μs min.</p> <p>ON 50% OFF</p> <p>3 μs max. 3 μs max.</p> <p>Phase-A/Phase-B encoder inputs, Differential phases, 30 kHz</p> <p>Changes in phases A and B must be separated by at least 4.0 μs.</p> <p>ON 50% OFF ON 50% OFF</p> <p>T1 T2 T3 T4 T1, T2, T3, T4: 4.0 μs min.</p>	<p>Encoder input phase A or B, single-phase 60-kHz pulse input with 50% duty ratio</p> <p>ON 50% OFF</p> <p>Phase-A/Phase-B encoder inputs, Differential phases, 30 kHz</p> <p>Changes in phases A and B must be separated by at least 4.0 μs.</p> <p>ON 50% OFF ON 50% OFF</p> <p>T1 T2 T3 T4 T1, T2, T3, T4: 4.0 μs min.</p>
	Set to 100 kHz	<p>Phase-A/Phase-B encoder input, Single-phase 100-kHz pulse input with 50% duty ratio</p> <p>Rise time and fall time: 2.5 μs max. 10.0 μs min.</p> <p>ON 50% OFF</p> <p>2.5 μs max. 2.5 μs max.</p> <p>Phase-A/Phase-B encoder inputs, Differential phases, 50 kHz</p> <p>Changes in phases A and B must be separated by at least 2.5 μs.</p> <p>ON 50% OFF ON 50% OFF</p> <p>T1 T2 T3 T4 T1, T2, T3, T4: 2.5 μs min.</p>
Phase Z/reset input		<p>Encoder input phase Z (IN02/IN03 or IN12/IN13)</p> <p>Maintain an ON time of 30 μs min. and an OFF time of 150 μs min.</p> <p>ON 50% OFF</p>



Additional Information

For the counter inputs, it is necessary to check the factors that can affect the pulses, such as the type of output driver in the encoder, cable length, and count pulse frequency. When counting pulses that exceed 60 kHz, we recommend using an encoder with a line-driver output. To ensure that pulses can be counted stably, use a shielded twisted-pair cable and keep the cable to 3 m or less in length.

3-1-2 Output Specifications for Sinking Transistor Outputs

● Normal Outputs (OUT00 to OUT05 and OUT10 to OUT15)

Output	Specifications
Rated voltage	5 to 24 VDC
Allowable voltage range	4.75 to 26.4 VDC
Maximum switching current	0.3 A/output; 1.8 A/Unit
Number of circuits	6 outputs (6 outputs/common)
Maximum inrush current	3.0 A/output, 10 ms max.*
Leakage current	0.1 mA max.
Residual voltage	0.6 V max.
ON response time	0.1 ms max.
OFF response time	0.1 ms max.
Fuse	None
External power supply (power supply input +V for outputs)	10.2 to 26.4 VDC 20 mA min.

* Refer to 4-3-2 *Wiring Examples* for details on suppressing the load's inrush current and modify the circuit if necessary.

● Pulse Outputs (OUT00 to OUT03 and OUT10 to OUT13)

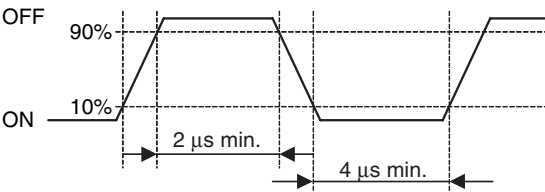
Item	Specifications
Rated voltage	5 to 24 VDC
Allowable voltage range	4.75 to 26.4 VDC
Maximum switching capacity	30 mA
Minimum switching capacity	7 mA
Maximum output frequency	100 kHz
Output waveform	

Note The ON/OFF status given above is for the output element.



Additional Information

- The load for the above values is assumed to be the resistance load, and does not take into account the impedance for the connecting cable to the load.
- Due to distortions in pulse waveforms resulting from connecting cable impedance, the pulse widths in actual operation may be smaller than the values shown above.

● PWM Outputs (OUT04, OUT05, OUT14, and OUT15)

Item	Specifications
Rated voltage	5 to 24 VDC
Allowable voltage range	4.75 to 26.4 VDC
Maximum switching capacity	6.5535 kHz or less: 300 mA, 6.5535 to 32.8 kHz: 100 mA
Maximum output frequency	32,800 Hz
PWM output accuracy (for ON pulse width of 2 μs or longer)	ON duty at 6.5535 kHz or less: -0.2% to +1%, ON duty at 32.8 kHz: -1% to +5% (at switching current of 30 mA)
Output waveform	<p>ON duty = $\frac{t_{ON}}{T} \times 100\%$</p>

Note The ON/OFF status given above is for the output element.

3-1-3 Output Specifications for Sourcing Transistor Outputs

● Normal Outputs (OUT00 to OUT05 and OUT10 to OUT15)

Output	OUT0 to OUT5
Rated voltage	5 to 24 VDC
Operating load voltage range	4.75 to 26.4 VDC
Maximum switching current	0.3 A/output, 1.8 A/Unit
Number of circuits	6 outputs (6 outputs/common)
Maximum inrush current	2.0 A/output, 10 ms max.*
Leakage current	0.1 mA max.
Residual voltage	0.6 V max.
ON response time	0.1 ms max.
OFF response time	0.1 ms max.
Fuse	None
External supply power (power supply input -V for outputs)	10.2 to 26.4 VDC, 20 mA min.

* Refer to 4-3-2 *Wiring Examples* for details on suppressing the load's inrush current and modify the circuit if necessary.

● Pulse Outputs (OUT00 to OUT03 and OUT10 to OUT13)

Item	Specifications
Rated voltage	5 to 24 VDC
Allowable voltage range	4.75 to 26.4 VDC
Maximum switching capacity	30 mA
Minimum switching capacity	7 mA
Maximum output frequency	100 kHz
Output waveform	

Note The ON/OFF status given above is for the output element.



Additional Information

- The load for the above values is assumed to be the resistance load, and does not take into account the impedance for the connecting cable to the load.
- Due to distortions in pulse waveforms resulting from connecting cable impedance, the pulse widths in actual operation may be smaller than the values shown above.

● **PWM Outputs (OUT04, OUT05, OUT14, and OUT15)**

Item	Specifications
Rated voltage	5 to 24 VDC
Allowable voltage range	4.75 to 26.4 VDC
Maximum switching capacity	6.5535 kHz or less: 300 mA, 6.5535 to 32.8 kHz: 100 mA
Maximum output frequency	32,800 Hz
PWM output accuracy (for ON pulse width of 2 μs or longer)	ON duty at 6.5535 kHz or less: ±0.5%, ON duty at 32.8 kHz: ±2.5% (at switching current of 30 mA)
Output waveform	

Note The ON/OFF status given above is for the output element.

3-2 Wiring

3-2-1 Connector Pin Allocations

● Connector on Sinking-type I/O Module (CJ2M-MD211)

Pin layout	Terminal symbol	Input signal type	Pin	*	Terminal symbol	Input signal type	Pin	*	
	IN00/IN10	24 VDC	1	A1	IN01/IN11	24 VDC	2	B1	
		LD+	3	A2		LD+	4	B2	
		0 V/LD-	5	A3		0 V/LD-	6	B3	
	IN02/IN12	24 VDC	7	A4	IN03/IN13	24 VDC	8	B4	
		LD+	9	A5		LD+	10	B5	
		0 V/LD-	11	A6		0 V/LD-	12	B6	
	IN04/IN14	24 VDC	13	A7	IN05/IN15	24 VDC	14	B7	
		LD+	15	A8		LD+	16	B8	
		0 V/LD-	17	A9		0 V/LD-	18	B9	
	IN06/IN16	24 VDC	19	A10	IN07/IN17	24 VDC	20	B10	
		LD+	21	A11		LD+	22	B11	
		0 V/LD-	23	A12		0 V/LD-	24	B12	
	IN08/IN18	24 VDC	25	A13	IN09/IN19	24 VDC	26	B13	
		LD+	27	A14		LD+	28	B14	
		0 V/LD-	29	A15		0 V/LD-	30	B15	
	OUT00/OUT10	---	---	31	A16	OUT01/OUT11	---	32	B16
	OUT02/OUT12	---	---	33	A17	OUT03/OUT13	---	34	B17
	OUT04/OUT14	---	---	35	A18	OUT05/OUT15	---	36	B18
	Power supply input +V for outputs	---	---	37	A19	Power supply input +V for outputs	---	38	B19
	COM	---	---	39	A20	COM	---	40	B20

* Terminals numbers on the XW2D-□□G□ Connector-Terminal Block Conversion Unit.

● Sourcing-type I/O Module (CJ2M-MD212)

Pin layout	Terminal symbol	Input signal type	Pin	*	Terminal symbol	Input signal type	Pin	*	
	IN00/IN10	24 VDC	1	A1	IN01/IN11	24 VDC	2	B1	
		LD+	3	A2		LD+	4	B2	
		0 V/LD-	5	A3		0 V/LD-	6	B3	
	IN02/IN12	24 VDC	7	A4	IN03/IN13	24 VDC	8	B4	
		LD+	9	A5		LD+	10	B5	
		0 V/LD-	11	A6		0 V/LD-	12	B6	
	IN04/IN14	24 VDC	13	A7	IN05/IN15	24 VDC	14	B7	
		LD+	15	A8		LD+	16	B8	
		0 V/LD-	17	A9		0 V/LD-	18	B9	
	IN06/IN16	24 VDC	19	A10	IN07/IN17	24 VDC	20	B10	
		LD+	21	A11		LD+	22	B11	
		0 V/LD-	23	A12		0 V/LD-	24	B12	
	IN08/IN18	24 VDC	25	A13	IN09/IN19	24 VDC	26	B13	
		LD+	27	A14		LD+	28	B14	
		0 V/LD-	29	A15		0 V/LD-	30	B15	
	OUT00/OUT10	---	---	31	A16	OUT01/OUT11	---	32	B16
	OUT02/OUT12	---	---	33	A17	OUT03/OUT13	---	34	B17
	OUT04/OUT14	---	---	35	A18	OUT05/OUT15	---	36	B18
	COM	---	---	37	A19	COM	---	38	B19
	Power supply input -V for outputs	---	---	39	A20	Power supply input -V for outputs	---	40	B20

* Terminals numbers on the XW2D-□□G□ Connector-Terminal Block Conversion Unit.

3-2-2 I/O Circuit Configurations

● **Input Circuits (IN00 to IN05 and IN10 to IN15)**

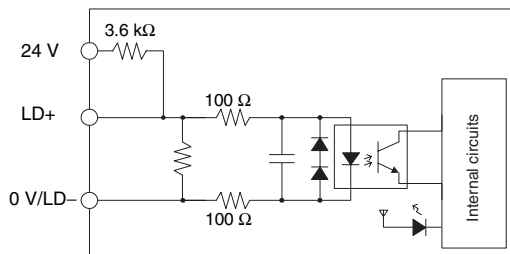

● **Input Circuits (IN06 to IN09 and IN16 to IN19)**

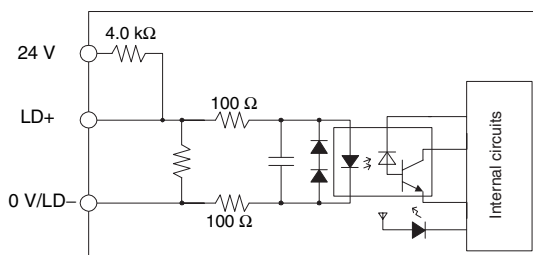

● **Output Circuits (OUT00 to OUT05 and OUT10 to OUT15)**

- Sinking-type I/O Module (CJ2M-MD211)
- Sourcing-type I/O Module (CJ2M-MD212)

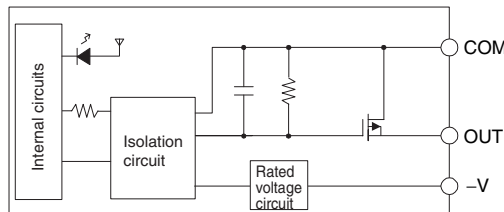
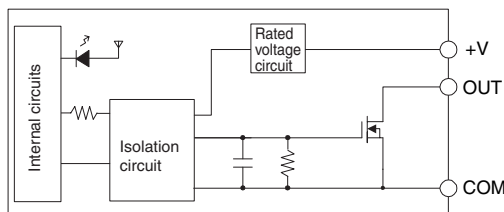

3-2-3 Wiring

There are the following three methods for wiring a Pulse I/O Module.

- **Using Connector-Terminal Block Conversion Units**
Connector-Terminal Block Conversion Units are used when using normal I/O, quick-response inputs, interrupt inputs, PWM outputs, or pulse outputs to stepping motors or other manufacturer's Servo Drives.
- **Using Servo Relay Units**
Servo Relay Units are used when using OMRON's Servo Drives.
- **Directly Connecting a Self-made Cable with a Connector**
A self-made cable with a Connector can be used to directly connect the I/O.



Precautions for Safe Use



- Never apply a voltage that exceeds the input voltage of the I/O circuits or the maximum switching capacity of the output circuits.
- When the power supply has positive and negative terminals, always wire them correctly.
- Use reinforced insulation or double insulation for the DC power supplies used for I/O to comply with the EC Low Voltage Directive.
- Always double-check the connector wiring before turning ON the power.
- Do not pull on the cable. Doing so will damage the cable.
- Do not bend the cable past its natural bending radius. Doing so will damage the cable.
- The connector pin allocation of the CJ1W-ID232/262 and OD233/263 connectors is not compatible. The Unit's internal circuits may be damaged if one of these connectors is connected.
- Do not connect a 24-VDC output device to a line driver input. Doing so may damage the internal circuits.
- Do not connect a line driver output device to the DC input. Doing so will not damage the internal circuits, but the input will not be recognized.

Using Connector-Terminal Block Conversion Units

A special OMRON Connecting Cable with a connector is used to connect the Connector-Terminal Block Conversion Unit.

● **Cables for Connector-Terminal Block Conversion Units**

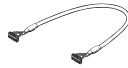
Applicable Connector-Terminal Block Conversion Units

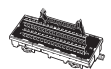
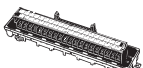
Connecting Cable	Compatible Connector-Terminal Block Conversion Unit	Type	Number of pins	Size	Temperature (°C)
XW2Z-□□□K  □□□: 100: 1 m 150: 1.5 m 200: 2 m 300: 3 m 500: 5 m	XW2D-40G6 	Slim type (M3 screw terminals)	40P	Compact	0 to 55
	XW2B-40G4 	Through cable (M3 screw terminals)		Standard	0 to 55
	XW2B-40G5 	Through cable (M3.5 screw terminals)			

● **Corresponding Connector-Terminal Block Conversion Unit Terminals**

The following figure shows the corresponding terminals on the Connector-Terminal Block Conversion Unit when it is connected to a Pulse I/O Module.

Pulse I/O Module	CJ2M-MD211, CJ2M-MD212
Connector-Terminal Block Conversion Unit	XW2D-40G6
Connecting Cable	XW2Z-□□□K

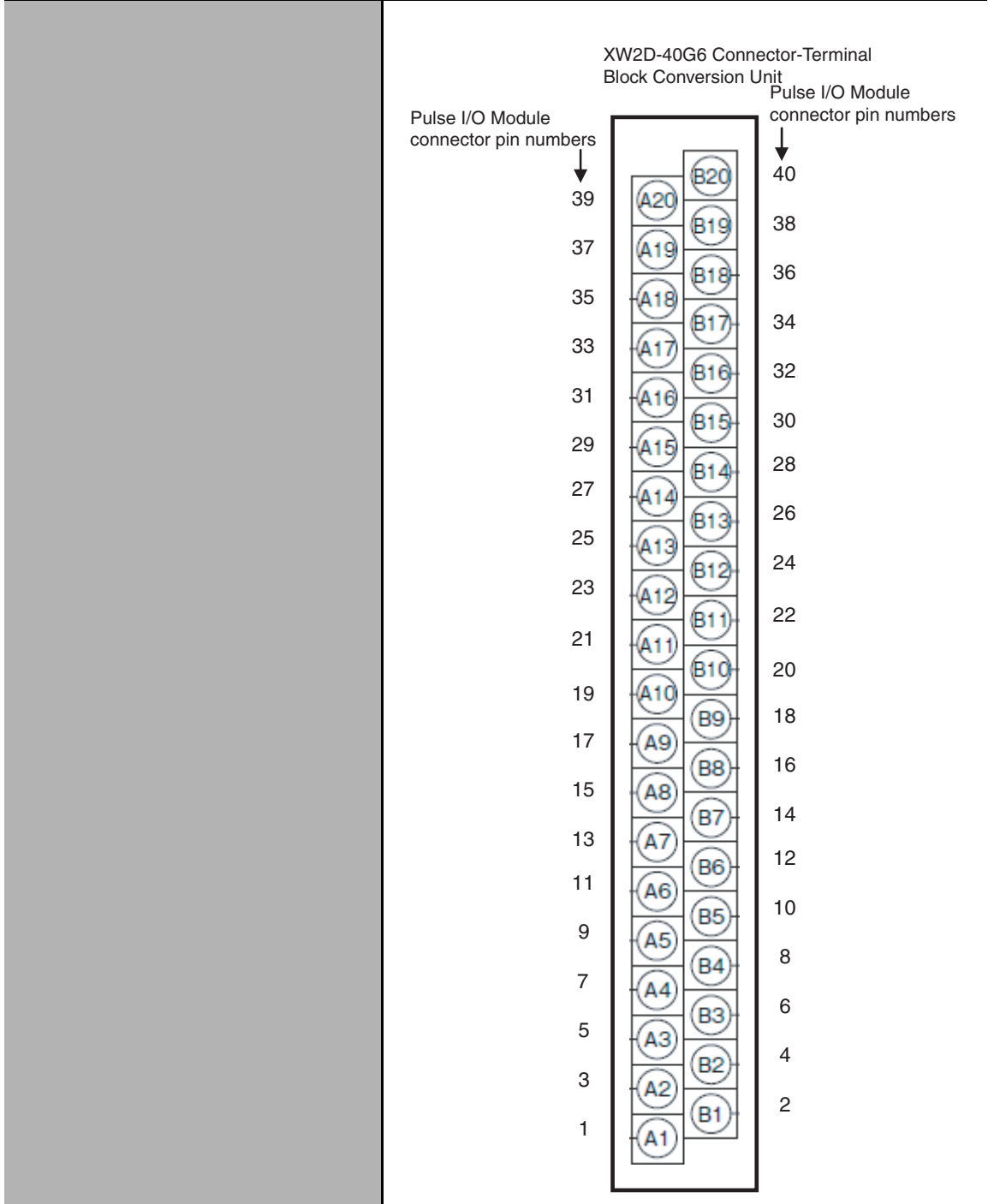

● **Connection Example When Using a Connector-Terminal Block Conversion Unit**

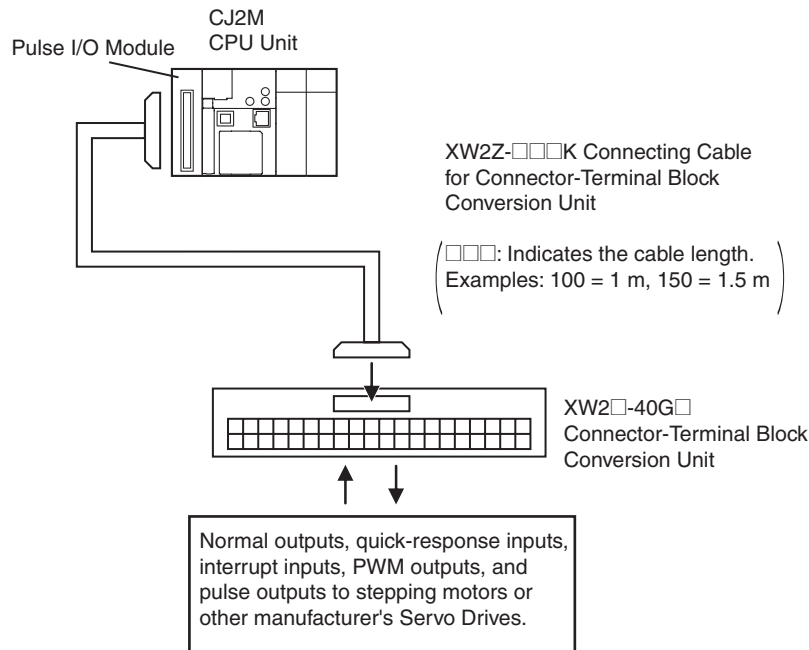

Using Servo Relay Units (Sinking Outputs Only)

Use special OMRON Connecting Cables with Connectors to connect between the Sinking-type Pulse I/O Module and the Servo Relay Unit and between the Servo Relay Unit and Servo Drive.

● **Connecting Cable for Servo Relay Units**

OMRON Servo Drive	Connecting Cable for Pulse I/O Module to Servo Relay Unit	Servo Relay Unit	Connecting Cable for Servo Relay Unit to Servo Drive
SMARTSTEP A Series (pulse string input)	1 m: XW2Z-100J-A26	Connecting one axis: XW2B-20J6-8A	1 m: XW2Z-100J-B5 2 m: XW2Z-200J-B5
SMARTSTEP Junior (pulse string input)	1 m: XW2Z-100J-A26		Connecting two axes: XW2B-40J6-9A
W Series (pulse string input)	0.5 m: XW2Z-050J-A27 1 m: XW2Z-100J-A27	1 m: XW2Z-100J-B4 2 m: XW2Z-200J-B4	
G Series (pulse string input)	0.5 m: XW2Z-050J-A33 1 m: XW2Z-100J-A33	1 m: XW2Z-100J-B31 2 m: XW2Z-200J-B31	
G5 Series (pulse string input)	0.5 m: XW2Z-050J-A33 1 m: XW2Z-100J-A33	1 m: XW2Z-100J-B31 2 m: XW2Z-200J-B31	
SMARTSTEP 2 Series (pulse string input)	0.5 m: XW2Z-050J-A33 1 m: XW2Z-100J-A33	1 m: XW2Z-100J-B32 2 m: XW2Z-200J-B32	

● **Connection Example When Using a Servo Relay Unit**

This is a connection example when the Servo Drive is connected to one or two axes using the Servo Relay Unit. In the connection example, the positioning/origin search connections (origin input signal, origin proximity input signal, and error counter reset output) with the Servo Drive are also wired.

Connecting One Servo Drive Using Pulse Output 0

Connecting to SMARTSTEP A-series or SMARTSTEP Junior Servo Drives

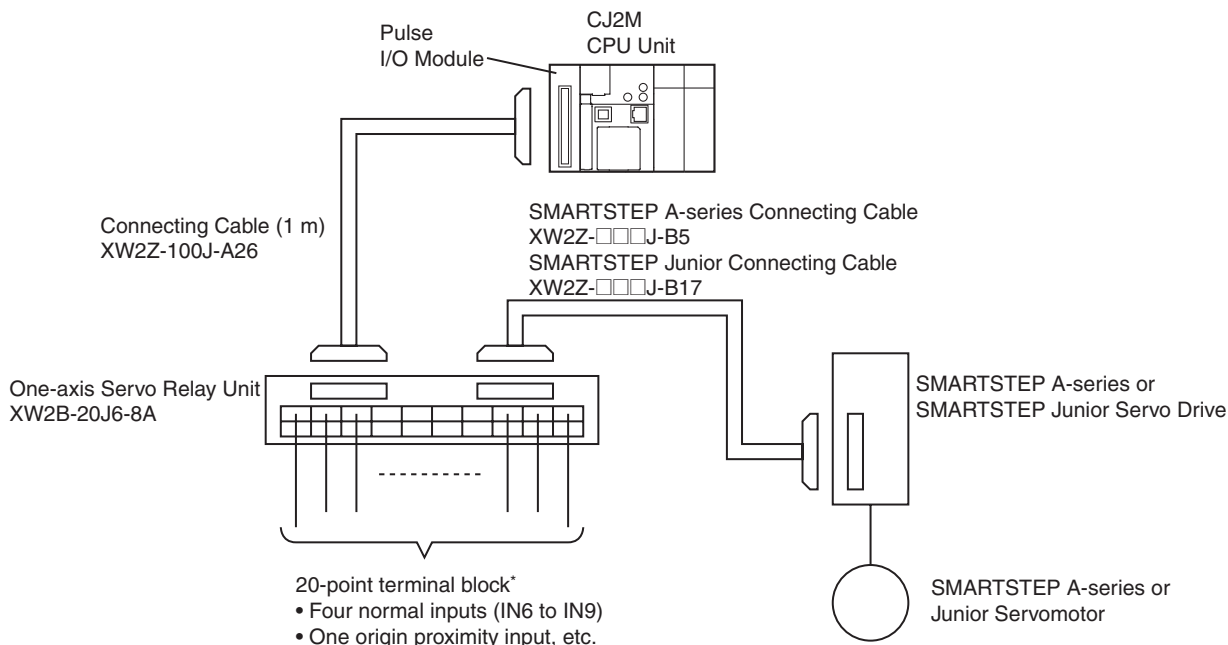

* If a One-axis Servo Relay Unit is connected to pulse output 0, the remaining outputs (normal outputs 2 and 3 (OUT2 and OUT3) and PWM output 1 (OUT5)) cannot be used.

Connecting to OMNUC W-series Servo Drives

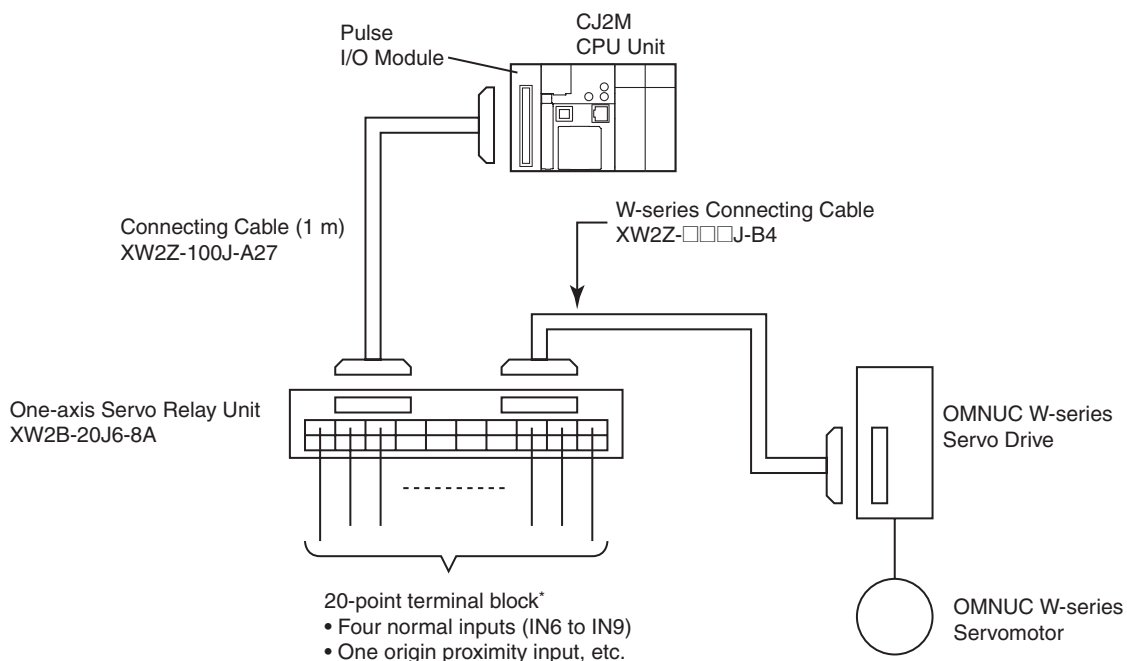

* If a One-axis Servo Relay Unit is connected to pulse output 0, the remaining outputs (normal outputs 2 and 3 (OUT2 and OUT3) and PWM output 1 (OUT5)) cannot be used.

Connecting an OMNUC G-series, G5-series, or SMARTSTEP 2-series Servo Drive

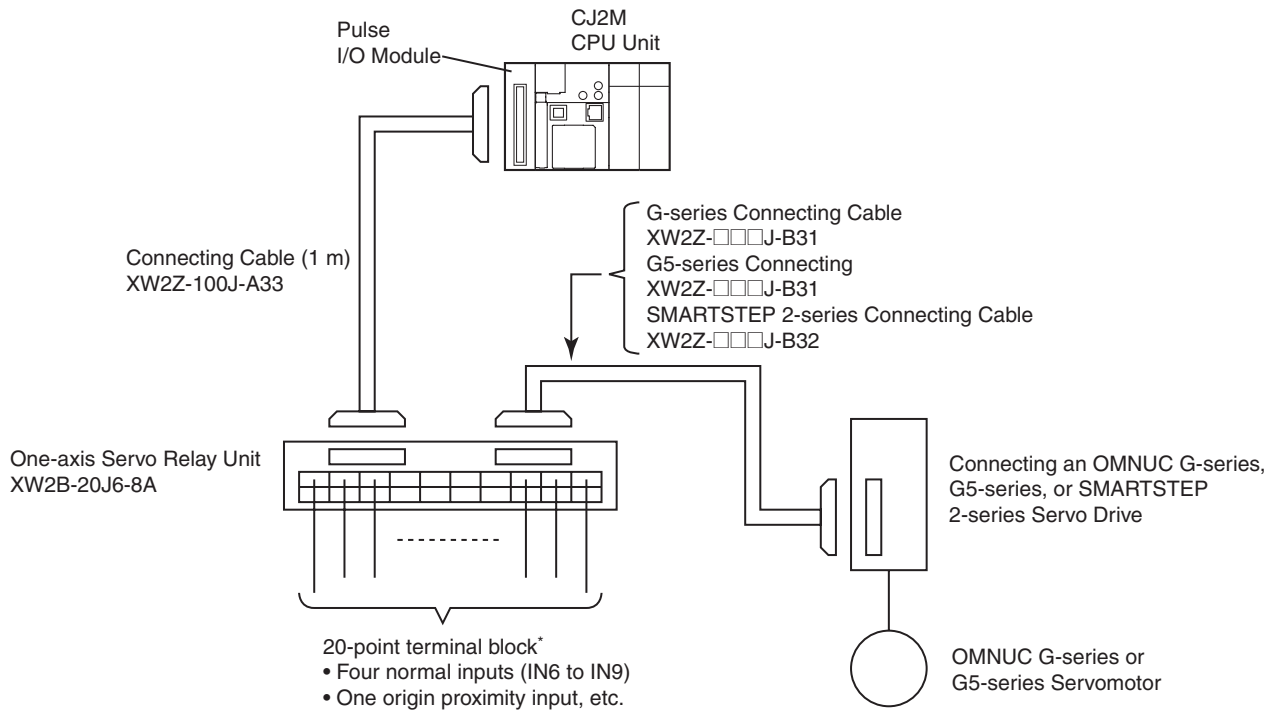

* If a One-axis Servo Relay Unit is connected to pulse output 0, the remaining outputs (normal outputs 2 and 3 (OUT2 and OUT3) and PWM output 1 (OUT5)) cannot be used.

Connecting Two Servo Drives Using Pulse Outputs 0 and 1

Connecting to SMARTSTEP A-series Servo Drives

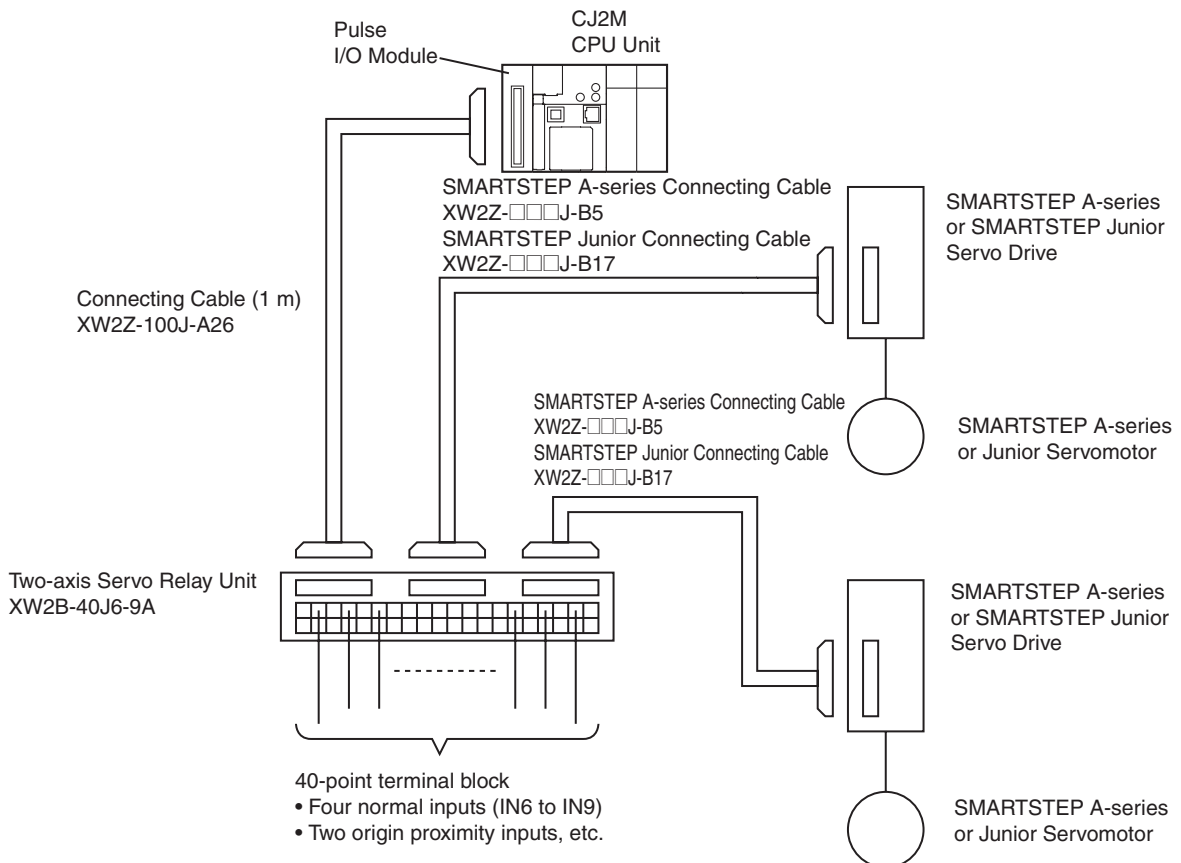

Connecting to OMNUC W-series Servo Drives

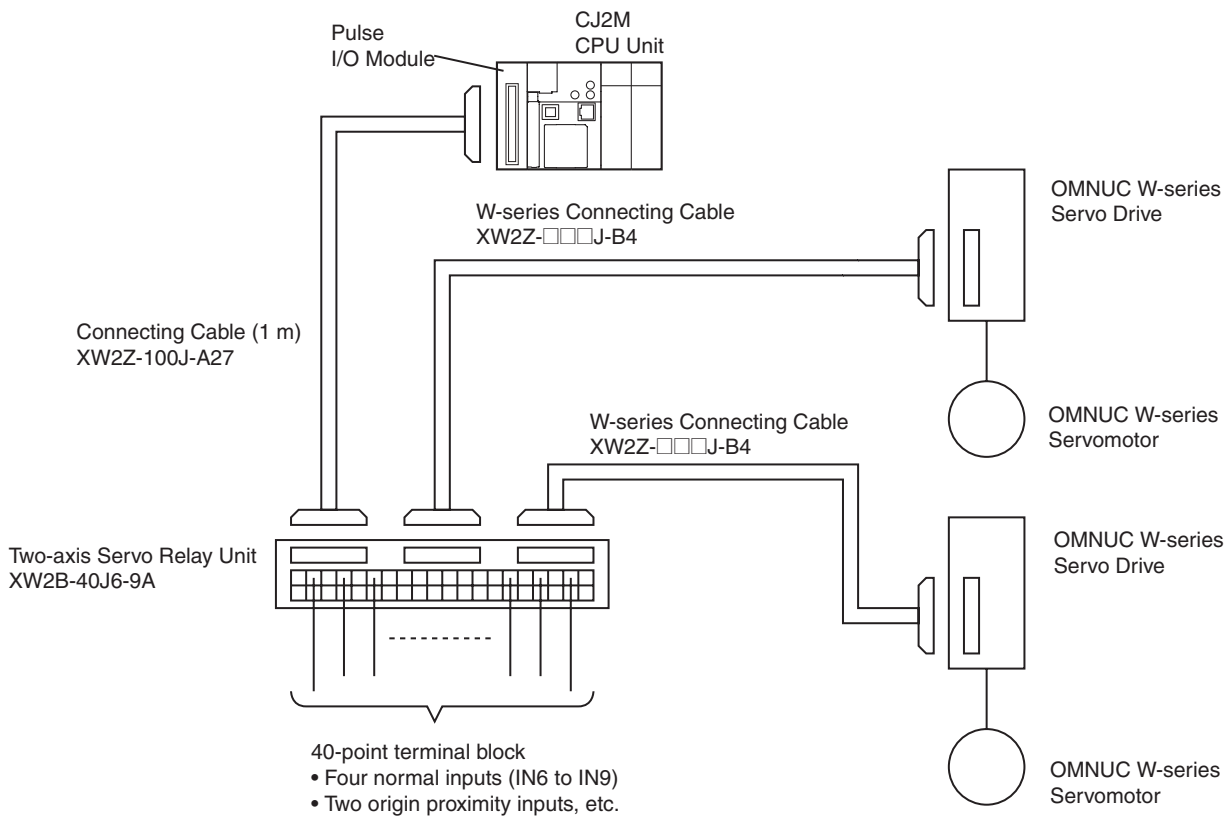

Connecting to OMNUC G-series, G5-series, or SMARTSTEP 2-series Servo Drives

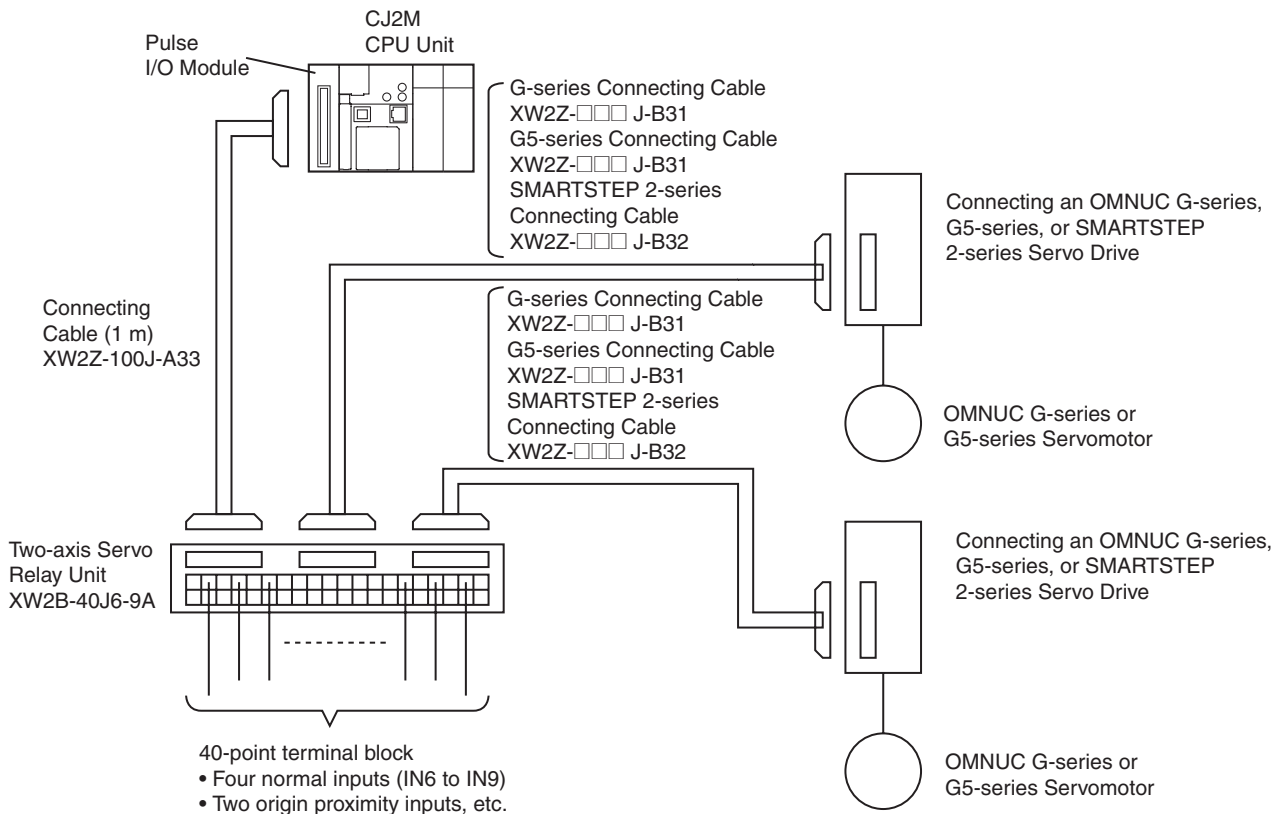

Directly Connecting a Self-made Cable with a Connector

● Types of Connectors

MIL Flat Cable Connectors (40-pin Pressure-fitted Connectors)

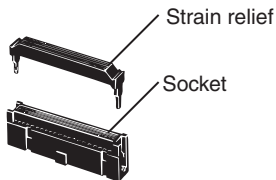

Name	OMRON model number	Daiichi Electronics model number
Socket	XG4M-4030	FRC5-AO40-3TON
Strain Relief	XG4T-4004	---
Set model number	XG4M-4030-T	FRC5-AO40-3TOS
Recommended Flat Cable	XY3A-400□	---

MIL Connectors with Loose Wires (40-pin Pressure-fitted Connectors)

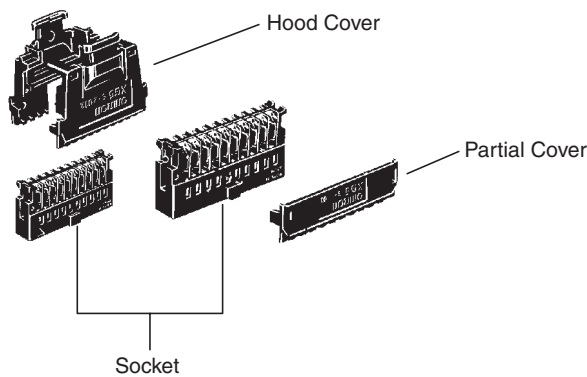

Name		OMRON model number
Socket	AWG24	XG5M-4032-N
	AWG 26 to 28	XG5M-4035-N
Contacts*1	AWG24	XG5W-0031-N
	AWG 26 to 28	XG5W-0034-N
Hood Cover*2		XG5S-4022
Semi-cover*2 (2 required for each socket)		XG5S-2001

*1 Contacts are included with the Socket.

*2 Select either the Hood Cover or the Partial Cover.

● Wire Sizes

We recommend using a cable with wires sized between 28 and 24 AWG (0.2 to 0.08 mm²). Use a wire with an outer diameter of 1.61 mm max.

4

Normal I/O

This section gives an overview of the normal inputs and outputs of the Pulse I/O Module, their functions, as well as the wiring methods.

4

4-1 Normal Inputs	4-2
4-1-1 Overview	4-2
4-1-2 Application Procedure	4-2
4-2 Normal Outputs	4-5
4-2-1 Overview	4-5
4-2-2 Flow of Operation	4-5
4-3 Wiring	4-7
4-3-1 Connector Pin Assignments	4-7
4-3-2 Wiring Examples	4-9

4-1 Normal Inputs

4-1-1 Overview

The status of input signals for normal inputs are read and stored in I/O memory during the I/O refresh period in the same way as it is for Input Units. The input time constant (ON/OFF response time) can also be set.

Bits 00 to 09 of CIO 2960 and CIO 2962 can be allocated as normal inputs.

Select the inputs in the PLC Setup.

4-1-2 Application Procedure

1

PLC Setup



2

Write the ladder program.

- The input terminals that are used for normal inputs on a Pulse I/O Module are also used for interrupt inputs, quick-response inputs, high-speed counter inputs, and origin searches.
- In the default settings for the PLC Setup, all input terminals are set for use as normal inputs.
- The input terminals that can be used as normal inputs can be checked in the Pulse I/O Module 0 or 1 assignments on the I/O Module Tab Page.
- Set the Normal Input Operation Setting (Input Time Constant Setting) in the PLC Setup to set the input time constant (ON/OFF response time). The settings are the same for IN00 to IN09 and IN10 to IN19.
The default is 8 ms.
Select from 0 ms (no filter), 0.5 ms, 1 ms, 2 ms, 4 ms, 8 ms, 16 ms, and 32 ms.
- Read the status using the LD instruction or other instructions.
- Use !LD instructions and other immediate refreshing version of instructions when immediate refreshing is required.
Note: Immediate refreshing cannot be performed by the IORF(097) instruction.

Applicable Input Terminals

The inputs listed in the following table can be used as normal inputs.

The input terminals that are used for normal inputs are also used for interrupt inputs, quick-response inputs, high-speed counter inputs, and origin searches. The same input terminal can be used for only one of these functions. For example, if normal output 2 is used, the high-speed counter 1 phase-Z signal + software reset, quick-response input 2, interrupt input 2, and pulse output 1 origin input (when performing origin searches) cannot be used.

Pulse I/O Module No.	Terminal symbol	Word	Bit	Function	Other functions that cannot be used at the same time			
					High-speed counter inputs	Quick-response inputs	Interrupt inputs	Origin search inputs for pulse outputs 0 to 3
0 (on the right)	IN00	CIO 2960	00	Normal input 0	---	Quick-response input 0	Interrupt input 0	Pulse output 0 origin input signal
	IN01		01	Normal input 1	---	Quick-response input 1	Interrupt input 1	Pulse output 0 origin proximity input signal
	IN02		02	Normal input 2	Counter 1 phase Z or reset input	Quick-response input 2	Interrupt input 2	Pulse output 1 origin input signal
	IN03		03	Normal input 3	Counter 0 phase Z or reset input	Quick-response input 3	Interrupt input 3	Pulse output 1 origin proximity input signal
	IN04		04	Normal input 4	---	---	---	Pulse output 0 positioning completed signal
	IN05		05	Normal input 5	---	---	---	Pulse output 1 positioning completed signal
	IN06		06	Normal input 6	Counter 1 phase A, increment, or count input	---	---	---
	IN07		07	Normal input 7	Counter 1 phase B, decrement, or direction input	---	---	---
	IN08		08	Normal input 8	Counter 0 phase A, increment, or count input	---	---	---
	IN09		09	Normal input 9	Counter 0 phase B, decrement, or direction input	---	---	---

Pulse I/O Module No.	Terminal symbol	Word	Bit	Function	Other functions that cannot be used at the same time			
					High-speed counter inputs	Quick-response inputs	Interrupt inputs	Origin search inputs for pulse outputs 0 to 3
1 (on the left)	IN10	CIO 2962	00	Normal input 10	---	Quick-response input 4	Interrupt input 4	Pulse output 2 origin input signal
	IN11		01	Normal input 11	---	Quick-response input 5	Interrupt input 5	Pulse output 2 origin proximity input signal
	IN12		02	Normal input 12	Counter 3 phase Z or reset input	Quick-response input 6	Interrupt input 6	Pulse output 3 origin input signal
	IN13		03	Normal input 13	Counter 2 phase Z or reset	Quick-response input 7	Interrupt input 7	Pulse output 3 origin proximity input signal
	IN14		04	Normal input 14	---	---	---	Pulse output 2 positioning completed signal
	IN15		05	Normal input 15	---	---	---	Pulse output 3 positioning completed signal
	IN16		06	Normal input 16	Counter 3 phase A, increment, or count input	---	---	---
	IN17		07	Normal input 17	Counter 3 phase B, decrement, or direction input	---	---	---
	IN18		08	Normal input 18	Counter 2 phase A, increment, or count input	---	---	---
	IN19		09	Normal input 19	Counter 2 phase B, decrement, or direction input	---	---	---

Specifications



Item	Specifications
Number of inputs	20 inputs
Allocated bit	CIO 2960 and CIO 2962, bits 00 to 09
Input time constant (ON/OFF response time)	Default: 8 ms The following settings can be made in the PLC Setup: 0 ms (no filter), 0.5 ms, 1 ms, 2 ms, 4 ms, 8 ms, 16 ms, or 32 ms.

4-2 Normal Outputs

4-2-1 Overview

Normal outputs are used to output standard output signals. The output point is refreshed when the allocated bit goes ON or OFF. Normal outputs are allocated to bits 00 to 05 of CIO 2961 and CIO 2963.

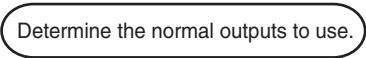
4-2-2 Flow of Operation

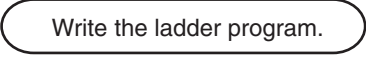
- 1  Determine the normal outputs to use.
 - Functions are assigned to output terminals when an instruction (such as OUT, ORG(889), or PWM(891)) is executed for an output bit.
- 
- 2  Write the ladder program.
 - Execute the OUT instruction or other instructions.
 - Use !OUT instructions and other immediate refreshing version of instructions when immediate refreshing is required.
Note: Immediate refreshing cannot be performed by the IORF(097) instruction.

Applicable Output Terminals

The outputs listed in the following table can be used as normal outputs.

The output terminals that are used for normal outputs are also used for pulse outputs, origin searches, and PWM outputs. The same output terminal can be used for only one of these functions. For example, if normal output 4 is used, PWM output 0 and the error counter reset for pulse output 0 (when performing origin searches) cannot be used.

Pulse I/O Module No.	Terminal symbol	Word	Bit	Function	Other functions that cannot be used at the same time			
					Pulse outputs			PWM outputs
					CW/CCW outputs	Pulse + direction outputs	Origin search outputs	
0 (on the right)	OUT00	CIO 2961	00	Normal output 0	CW pulse output 0	Pulse output 0	---	---
	OUT01		01	Normal output 1	CCW pulse output 0	Pulse output 1	---	---
	OUT02		02	Normal output 2	CW pulse output 1	Direction output 0	---	---
	OUT03		03	Normal output 3	CCW pulse output 1	Direction output 1	---	---
	OUT04		04	Normal output 4	---	---	Pulse output 0 error counter reset output	PWM output 0
	OUT05		05	Normal output 5	---	---	Pulse output 1 error counter reset output	PWM output 1
1 (on the left)	OUT10	CIO 2963	00	Normal output 6	CW pulse output 2	Pulse output 2	---	---
	OUT11		01	Normal output 7	CCW pulse output 2	Pulse output 3	---	---
	OUT12		02	Normal output 8	CW pulse output 3	Direction output 2	---	---
	OUT13		03	Normal output 9	CCW pulse output 3	Direction output 3	---	---
	OUT14		04	Normal output 10	---	---	Pulse output 2 error counter reset output	PWM output 2
	OUT15		05	Normal output 11	---	---	Pulse output 3 error counter reset output	PWM output 3

Specifications

Item	Specifications
Number of outputs	12 outputs
Allocated bit	CIO 2961 and CIO 2963, bits 00 to 05

4-3 Wiring

4-3-1 Connector Pin Assignments

Normal Inputs

Pulse I/O Module No. 0 (on the right)					Pulse I/O Module No. 1 (on the left)				
Input type and number	Terminal symbol	Pin	(*)	Description	Input type and number	Terminal symbol	Pin	(*)	Description
Normal input 0	IN00	1	A1	24-VDC input	Normal input 10	IN10	1	A1	24-VDC input
		5	A3	0 V			5	A3	0 V
Normal input 1	IN01	2	B1	24-VDC input	Normal input 11	IN11	2	B1	24-VDC input
		6	B3	0 V			6	B3	0 V
Normal input 2	IN02	7	A4	24-VDC input	Normal input 12	IN12	7	A4	24-VDC input
		11	A6	0 V			11	A6	0 V
Normal input 3	IN03	8	B4	24-VDC input	Normal input 13	IN13	8	B4	24-VDC input
		12	B6	0 V			12	B6	0 V
Normal input 4	IN04	13	A7	24-VDC input	Normal input 14	IN14	13	A7	24-VDC input
		17	A9	0 V			17	A9	0 V
Normal input 5	IN05	14	B7	24-VDC input	Normal input 15	IN15	14	B7	24-VDC input
		18	B9	0 V			18	B9	0 V
Normal input 6	IN06	19	A10	24-VDC input	Normal input 16	IN16	19	A10	24-VDC input
		23	A12	0 V			23	A12	0 V
Normal input 7	IN07	20	B10	24-VDC input	Normal input 17	IN17	20	B10	24-VDC input
		24	B12	0 V			24	B12	0 V
Normal input 8	IN08	25	A13	24-VDC input	Normal input 18	IN18	25	A13	24-VDC input
		29	A15	0 V			29	A15	0 V
Normal input 9	IN09	26	B13	24-VDC input	Normal input 19	IN19	26	B13	24-VDC input
		30	B15	0 V			30	B15	0 V

* Terminal numbers on the XW2D-□□G□ Connector-Terminal Block Conversion Unit.

Normal Outputs

● Sinking-type Pulse I/O Module (CJ2M-MD211)

Pulse I/O Module No. 0 (on the right)					Pulse I/O Module No. 1 (on the left)				
Output type and number	Terminal symbol	Pin	(*)	Description	Output type and number	Terminal symbol	Pin	(*)	Description
Normal output 0	OUT00	31	A16	Output 0	Normal output 6	OUT10	31	A16	Output 0
Normal output 1	OUT01	32	B16	Output 1	Normal output 7	OUT11	32	B16	Output 1
Normal output 2	OUT02	33	A17	Output 2	Normal output 8	OUT12	33	A17	Output 2
Normal output 3	OUT03	34	B17	Output 3	Normal output 9	OUT13	34	B17	Output 3
Normal output 4	OUT04	35	A18	Output 4	Normal output 10	OUT14	35	A18	Output 4
Normal output 5	OUT05	36	B18	Output 5	Normal output 11	OUT15	36	B18	Output 5
---		37	A19	Power supply input +V for outputs	---		37	A19	Power supply input +V for outputs
		38	B19				38	B19	
---		39	A20	COM	---		39	A20	COM
		40	B20				40	B20	

* Terminals numbers on the XW2D-□□G□ Connector-Terminal Block Conversion Unit.

● Sourcing-type Pulse I/O Module (CJ2M-MD212)

Pulse I/O Module No. 0 (on the right)					Pulse I/O Module No. 1 (on the left)				
Output type and number	Terminal symbol	Pin	(*)	Description	Output type and number	Terminal symbol	Pin	(*)	Description
Normal output 0	OUT00	31	A16	Output 0	Normal output 6	OUT10	31	A16	Output 0
Normal output 1	OUT01	32	B16	Output 1	Normal output 7	OUT11	32	B16	Output 1
Normal output 2	OUT02	33	A17	Output 2	Normal output 8	OUT12	33	A17	Output 2
Normal output 3	OUT03	34	B17	Output 3	Normal output 9	OUT13	34	B17	Output 3
Normal output 4	OUT04	35	A18	Output 4	Normal output 10	OUT14	35	A18	Output 4
Normal output 5	OUT05	36	B18	Output 5	Normal output 11	OUT15	36	B18	Output 5
---		37	A19	COM	---		37	A19	COM
		38	B19				38	B19	
---		39	A20	Power supply input -V for outputs	---		39	A20	Power supply input -V for outputs
		40	B20				40	B20	

* Terminals numbers on the XW2D-□□G□ Connector-Terminal Block Conversion Unit.

4-3-2 Wiring Examples

Examples for DC Input Devices

• Device with Contact Outputs

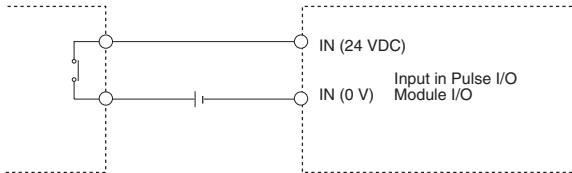

• Two-wire DC Sensor

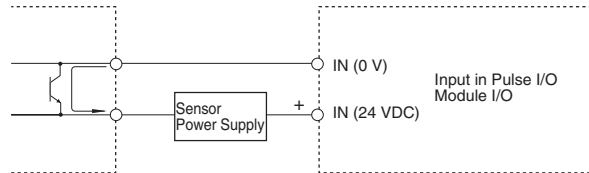

• Device with NPN Open Collector Output

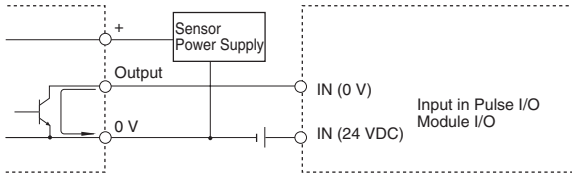

• Device with NPN Current Output

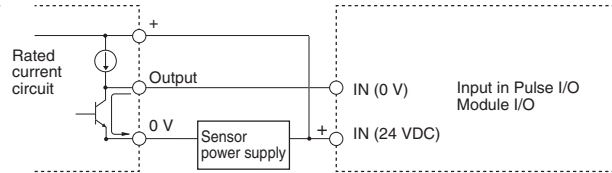

• Device with PNP Current Output

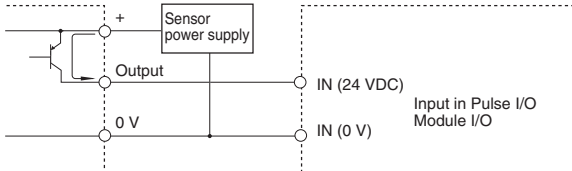

• Device with Voltage Output

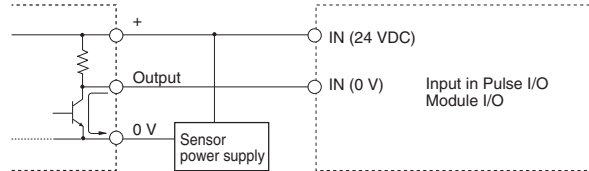

Note: Do not use the following wiring with voltage-output devices.

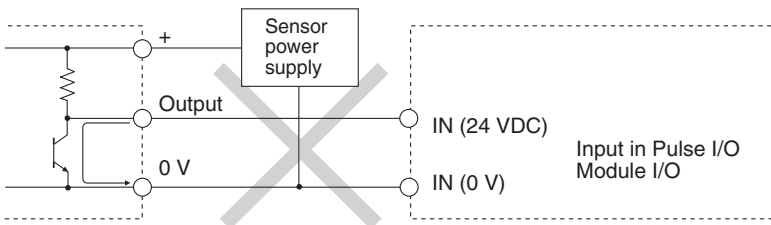

Precautions for Correct Use

The Pulse I/O Module inputs have polarity. The inputs will not go ON if the wiring is reversed. Always double-check the wiring before turning ON the power.

Precautions When Connecting a Two-wire DC Sensor

When using a two-wire sensor, check that the following conditions have been met. Failure to meet these conditions may result in operating errors.

(1) Relation between voltage when the input is ON and the sensor residual voltage:

$$V_{ON} \leq V_{CC} - V_R$$

(2) Relation between current when the input is ON and the sensor control output (load current):

$$I_{OUT} (\text{min.}) \leq I_{ON} \leq I_{OUT} (\text{max.})$$

$$I_{ON} = (V_{CC} - V_R - 1.5 [\text{Internal residual voltage of input}]) / R_{IN}$$

When I_{ON} is smaller than $I_{OUT} (\text{min.})$, connect a bleeder resistor R. The bleeder resistor constant can be calculated as follows:

$$R \leq (V_{CC} - V_R) / (I_{OUT} (\text{min.}) - I_{ON})$$

$$\text{Power } W \geq (V_{CC} - V_R)^2 / R \times 4 \text{ (allowable margin)}$$

(3) Relation between current when the input is OFF and the sensor leakage current:

$$I_{OFF} \geq I_{leak}$$

Connect a bleeder resistor if I_{leak} is greater than I_{OFF} .

Use the following equation to calculate the bleeder resistance constant.

$$R \leq R_{IN} \times V_{OFF} / (I_{leak} \times R_{IN} - V_{OFF})$$

$$\text{Power } W \geq (V_{CC} - V_R)^2 / R \times 4 \text{ (allowable margin)}$$

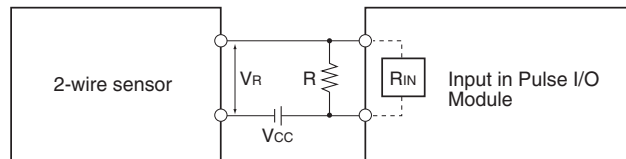

V_{CC} : Power supply voltage

V_R : Sensor's output residual voltage

V_{ON} : Input's ON voltage

V_{OFF} : Input's OFF voltage

I_{ON} : Input's ON current

I_{OUT} : Sensor's control current (load current)

I_{OFF} : Input's OFF current

I_{leak} : Sensor's leakage current

R_{IN} : Input's impedance

R: Bleeder resistance

(4) Precautions on Sensor Inrush Current

An incorrect input may occur due to sensor inrush current if a sensor is turned ON after the PLC has started up to the point where inputs are possible.

Determine the time required for sensor operation to stabilize after the sensor is turned ON and take appropriate measures, such as inserting into the program a timer delay after turning ON the sensor.

Programming Example

In this example, the sensor's power supply voltage is used as the input to CIO 0.00. A 100-ms timer delay (the time required for an OMRON Proximity Sensor to stabilize) is created in the program.

After the Completion Flag for the timer turns ON, the sensor input on input bit CIO 0.01 will cause output bit CIO 1.00 to turn ON.

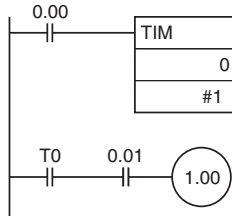

Output Wiring Precautions

● Output Short Protection

If a load connected to the output terminals is short-circuited, output components and the printed circuit boards may be damaged. To guard against this, incorporate a fuse in the external circuit. Use a fuse with a capacity of about twice the rated output.

Precautions on Inrush Current

When switching a load with a high inrush current, such as an incandescent light bulb, there is a risk of damaging the output transistor. Use either of the following methods to reduce the inrush current.

Method 1

This method draws a dark current that is approximately one-third of the rated value of the light bulb.

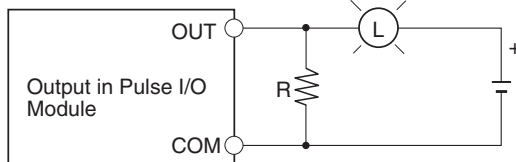

Method 2

This method uses a limiting resistor.

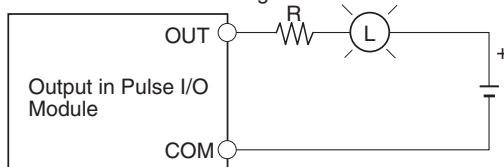

5

Quick-response Inputs

This section describes the quick-response inputs that can be used to read signals that are shorter than the cycle time.

5-1 Overview	5-2
5-2 Application Procedure	5-3
5-2-1 PLC Setup	5-3
5-2-2 Applicable Input Terminals	5-5
5-3 Wiring	5-6
5-3-1 Connector Pin Assignments	5-6
5-4 Creating Ladder Programs	5-7

5-1 Overview

By setting an input on the Pulse I/O Module to quick-response input operation, inputs with signal widths as small as 30 μs can be read with certainty regardless of the cycle time. Use the quick-response inputs to read signals shorter than the cycle time, such as inputs from photomicrosensors.

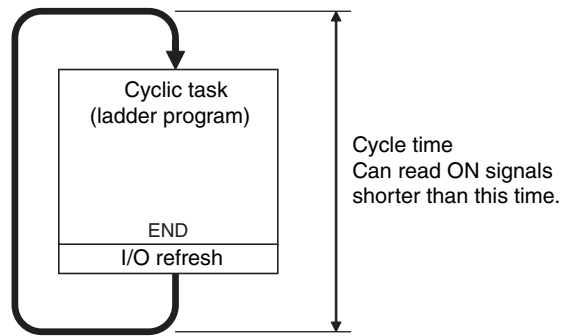
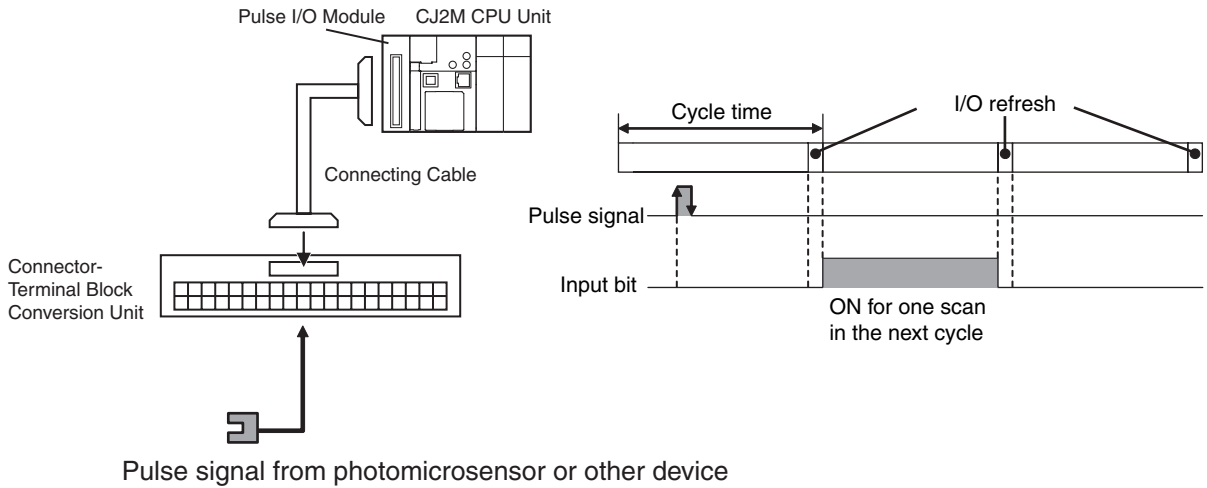

The pulse widths of quick-response input signals must meet the following conditions.

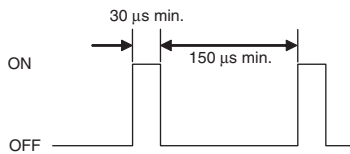

5-2 Application Procedure

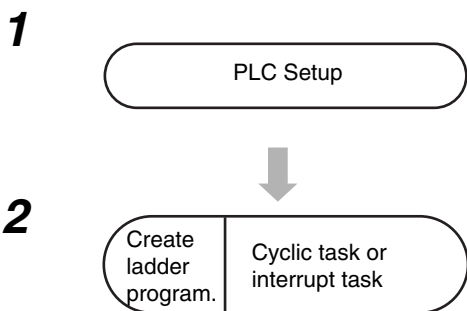

- Select *Quick-response Input* in the Interrupt Input and Quick-response Input Detailed Settings Dialog Box that is accessed from the I/O Module Tab Page of the PLC Setup using the CX-Programmer.
- IN00 to IN03 and IN10 to IN13 can be used for quick-response inputs.

Read bit status using the LD instruction or other instructions.

5-2 Application Procedure

5

5-2-1 PLC Setup

5-2-1 PLC Setup

Click the **Set** Button in the Interrupt Inputs and Quick-response Inputs Area on the I/O Module Tab Page of the PLC Setup. Select *Quick-response Input* for the input operation in the Interrupt Input and Quick-response Input Detailed Settings Dialog Box.

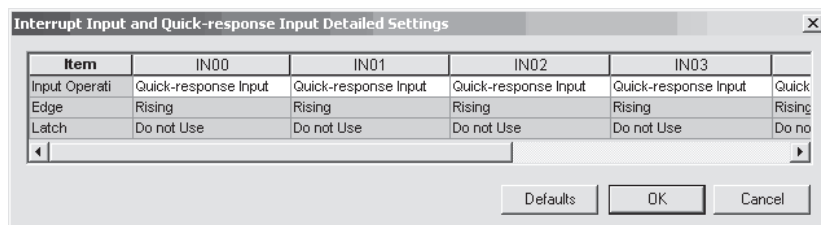
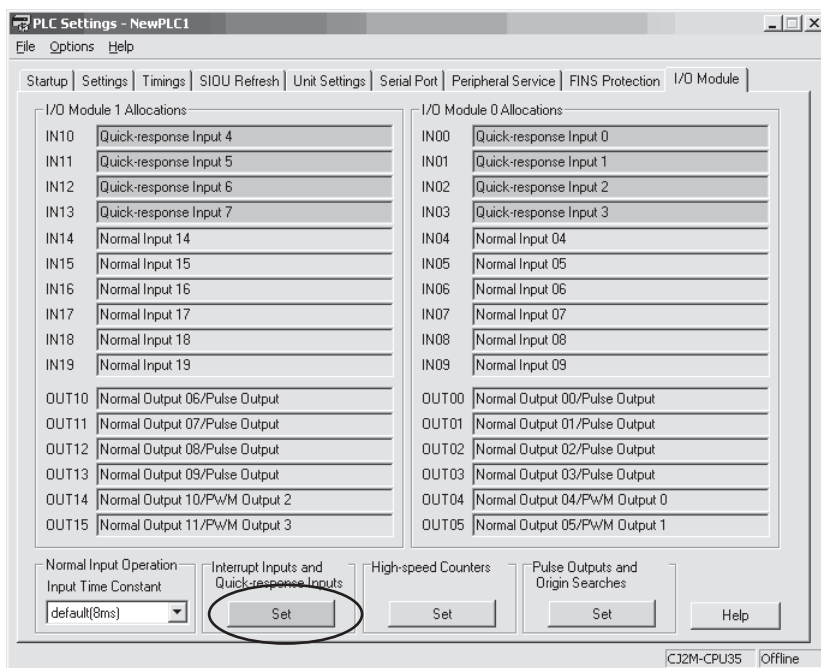

Interrupt Input and Quick-response Input Detailed Settings

Pulse I/O Module No.	Input Operation		Corresponding bit address
0 (on the right)	IN00	Select <i>Quick</i> for IN00 to IN03 or IN10 to IN13.	CIO 2960.00
	IN01		CIO 2960.01
	IN02		CIO 2960.02
	IN03		CIO 2960.03
1 (on the left)	IN10		CIO 2962.00
	IN11		CIO 2962.01
	IN12		CIO 2962.02
	IN13		CIO 2962.03

Note The power supply must be restarted after the PLC Setup is transferred in order to validate the quick-response input settings.

5-2-2 Applicable Input Terminals

The following terminals can be used for quick-response inputs.

The input terminals that are used for quick-response inputs are also used for normal inputs, interrupt inputs, high-speed counter inputs, and origin searches. The same input terminal can be used for only one of these functions. For example, if quick-response input 2 is used, normal input 2, the phase Z/reset method for high-speed counter 1, interrupt input 2, and the origin input signal for pulse output 1 (when performing origin searches) cannot be used.

Pulse I/O Module No.	Terminal symbol	Word	Bits	Function	Other functions that cannot be used at the same time			
					High-speed counter inputs	Normal inputs	Interrupt inputs	Origin search inputs for pulse outputs 0 to 3
0 (on the right)	IN00	CIO 2960	00	Quick-response input 0	---	Normal input 0	Interrupt input 0	Pulse output 0 origin input signal
	IN01		01	Quick-response input 1	---	Normal input 1	Interrupt input 1	Pulse output 0 origin proximity input signal
	IN02		02	Quick-response input 2	Counter 1 phase Z or reset	Normal input 2	Interrupt input 2	Pulse output 1 origin input signal
	IN03		03	Quick-response input 3	Counter 0 phase Z or reset	Normal input 3	Interrupt input 3	Pulse output 1 origin proximity input signal
1 (on the left)	IN10	CIO 2962	00	Quick-response input 4	---	Normal input 10	Interrupt input 4	Pulse output 2 origin input signal
	IN11		01	Quick-response input 5	---	Normal input 11	Interrupt input 5	Pulse output 2 origin proximity input signal
	IN12		02	Quick-response input 6	Counter 3 phase Z or reset	Normal input 12	Interrupt input 6	Pulse output 3 origin input signal
	IN13		03	Quick-response input 7	Counter 2 phase Z or reset	Normal input 13	Interrupt input 7	Pulse output 3 origin proximity input signal

Related Auxiliary Area Bits

There are no Auxiliary Area bits or words that are related to the quick-response inputs.

Applicable Instructions

There are no instructions that are related to the quick-response inputs.

5-3 Wiring

5-3-1 Connector Pin Assignments

The following terminals can be used for quick-response inputs.

Pulse I/O Module No. 0 (on the right)					Pulse I/O Module No. 1 (on the left)				
Input type and number	Terminal symbol	Pin	(*)	Description	Input type and number	Terminal symbol	Pin	(*)	Description
Quick-response input 0	IN00	1	A1	24-VDC input	Quick-response input 4	IN10	1	A1	24-VDC input
		5	A3	0 V			5	A3	0 V
Quick-response input 1	IN01	2	B1	24-VDC input	Quick-response input 5	IN11	2	B1	24-VDC input
		6	B3	0 V			6	B3	0 V
Quick-response input 2	IN02	7	A4	24-VDC input	Quick-response input 6	IN12	7	A4	24-VDC input
		11	A6	0 V			11	A6	0 V
Quick-response input 3	IN03	8	B4	24-VDC input	Quick-response input 7	IN13	8	B4	24-VDC input
		12	B6	0 V			12	B6	0 V

* Terminals numbers on the XW2D-□□G□ Connector-Terminal Block Conversion Unit.

5-4 Creating Ladder Programs

Pulse inputs shorter than the cycle time can be read in the CPU Unit I/O memory using normal instructions by selecting *Quick-response Input* for the input terminal in the PLC Setup.

The status of CIO 2960.00 to CIO 2960.03 and CIO 2962.00 to CIO 2962.03 can be read using instructions such as the LD instruction.

Example: Setting IN02 to *Quick-response Input* in the PLC Setup

Even if the signal that is input to input terminal 02 is shorter than the cycle time, the signal will be latched in one cycle and the status will be stored in CIO 2960.02.



- The minimum pulse width (ON time) that can be read for a quick-response input is 30 μ s.
- The status of the input that is stored in the I/O memory for a short input will be cleared during the next I/O refresh period.

6

Interrupts

This section gives an overview of the interrupt function and how to use it, as well as a description of the wiring method.

6-1	Types of Interrupts	6-2
6-1-1	Overview	6-2
6-2	Interrupt Inputs	6-3
6-2-1	Overview	6-3
6-2-2	Application Procedure	6-5
6-2-3	Specifications	6-5
6-2-4	PLC Setup	6-6
6-2-5	Wiring	6-10
6-2-6	Creating Ladder Programs	6-10
6-2-7	Application Example	6-14

6-1 Types of Interrupts

6-1-1 Overview

CJ2M CPU Units normally repeat processes in the following order: overseeing processes, program execution, I/O refreshing, peripheral servicing. During the program execution stage, cyclic tasks (ladder programs) are executed.

The interrupt function, on the other hand, allows a specified condition to interrupt a cycle and execute a specified program. Interrupts can thus be used to perform high-speed processing that is not restricted by the cycle time. The CJ2M CPU Unit performs the following:

- (1) When an interrupt occurs, execution of the ladder programs in cyclic tasks is interrupted.
- (2) The ladder program in the interrupt task is executed.
- (3) When the interrupt task is finished, the ladder program that was being executed is returned to.

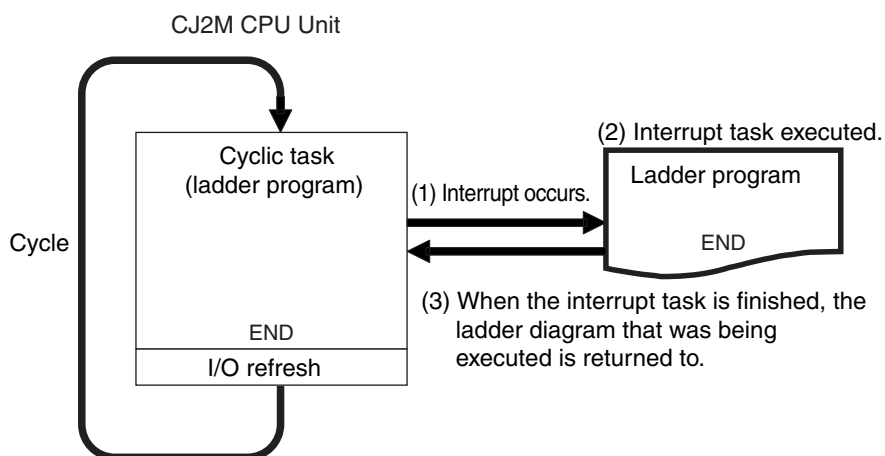

Interrupt Factors and Types of Interrupts

Interrupts are classified by the interrupt factor. There are the following three types of interrupts.

- Changes in status of inputs on Pulse I/O Module → 6-2 *Interrupt Inputs*
- PVs of high-speed counters → 7-3 *High-speed Counter Interrupts*
- Specified time interval for timer in the CPU Unit → Scheduled interrupts
(Refer to the *CJ2 CPU Unit Software Manual* (Cat. No. W473).)



Additional Information

For information on using interrupt tasks, refer to the *CJ2 CPU Unit Software User's Manual* (Cat. No. W473).

6-2 Interrupt Inputs

6-2-1 Overview

Interrupt inputs can be used in either Direct Mode or Counter Mode.

Interrupt Input in Direct Mode:

A corresponding interrupt task can be executed when an Pulse I/O Module input turns ON or turns OFF. The PLC Setup or MSKS(690) instruction determines whether the interrupt is triggered when the input turns ON or when it turns OFF.

Interrupt Input in Counter Mode:

A corresponding interrupt task can be executed when the number of times the Pulse I/O Module input turns ON or turns OFF reaches the set value (A532 to A535 and A544 to A547) in Increment Mode, or when it reaches zero in Decrement Mode.

The number of the interrupt tasks started by interrupt inputs must be between 140 and 147.

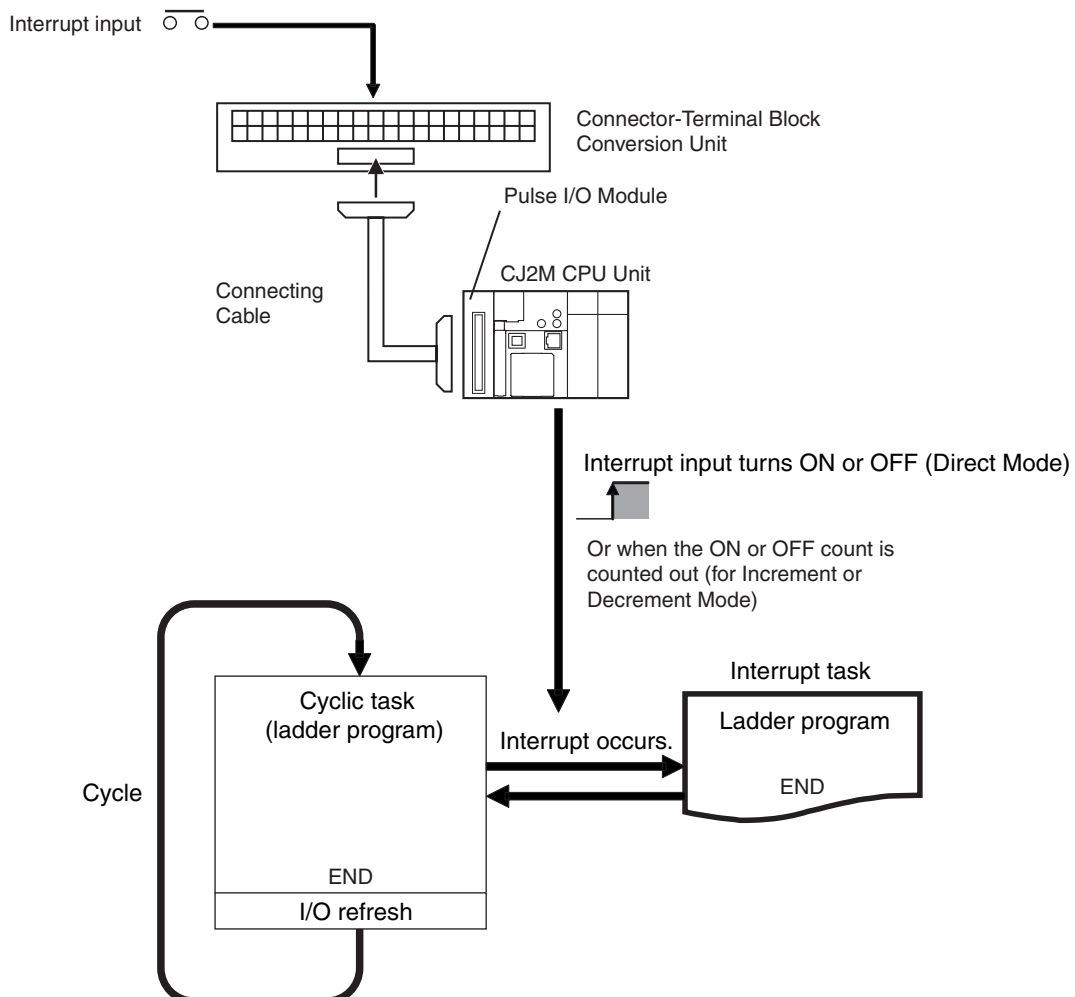

● Direct Mode

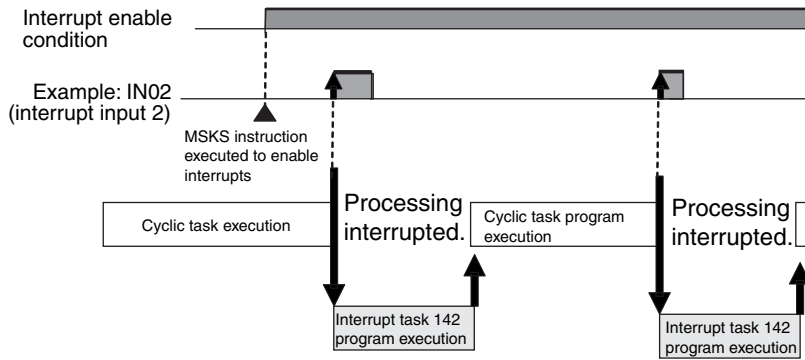

● Counter Mode

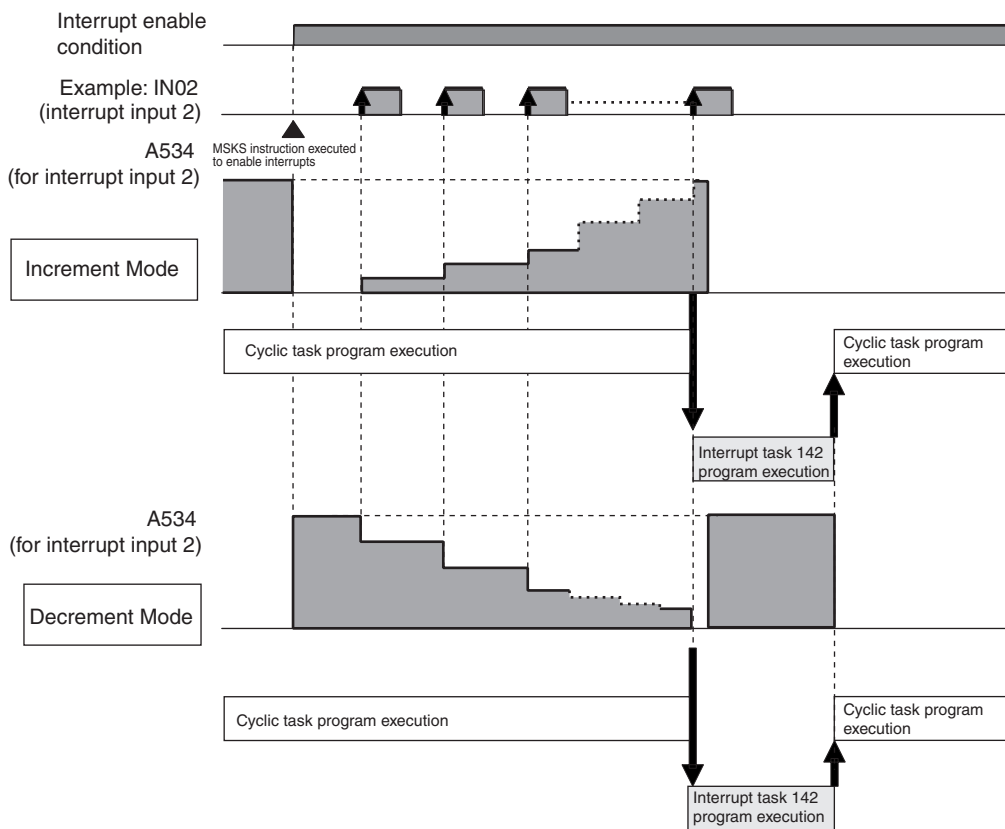

The pulse widths of interrupt input signals must meet the following conditions.

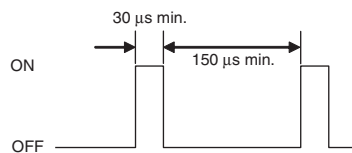

6-2-2 Application Procedure

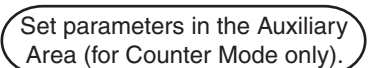
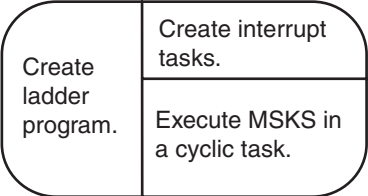
- 1**  PLC Setup
- Select *Quick-response Input* in the Quick-response Input Detailed Settings Dialog Box that is accessed from the I/O Module Tab Page of the PLC Setup using the CX-Programmer.
 - This will allocate inputs IN00 to IN03 or IN10 to IN13 for interrupt inputs.
 - Specify when changing from PROGRAM mode to RUN mode whether to detect ON or OFF transitions in inputs.
 - Specify whether to latch the PV of a pulse output/high-speed counter when an interrupt task is started.
- 2**  Set parameters in the Auxiliary Area (for Counter Mode only).
- When using Counter Mode, set the counter set values for interrupt input counters 0 to 7 in Auxiliary Area words A532 to A535 and A544 to A547.
- 3**  Create ladder program. Create interrupt tasks. Execute MSKS in a cyclic task.
- Write the program in the interrupt task. Interrupt tasks 140 to 147 correspond to IN00 to IN03 and IN10 to IN13. The following are specified using two MSKS(690) instructions.
 - Specify whether to detect OFF or ON transitions to use a different setting from the one in the PLC Setup. Specify N to 110 to 117 in the MSKS(690) instruction.
 - Select the type of interrupt input (Direct Mode or Counter Mode). If Counter Mode is selected, select Increment or Decrement Counter Mode and enable interrupts. Set N to 100 to 107 in the MSKS(690) instruction.

6-2-3 Specifications

Item	Direct Mode	Counter Mode
Number of interrupt inputs	8 inputs	
Allocated bit	CIO 2960 and CIO 2962, bits 00 to 03	
Interrupt detection method	ON-to-OFF or OFF-to-ON transitions	
Interrupt task numbers	140 to 147 (fixed)	
Counting method	---	Incrementing or decrementing (Set with the MSKS(690) instruction.)
Counting range	---	0001 to FFFF hex (16 bits) (Set in A532 to A535 and A544 to A547.)
Response frequency	---	Single-phase: 3 kHz x 8 inputs
Storage locations for PVs for interrupt inputs in Counter Mode	---	A536 to A539 and A548 to A551



Precautions for Correct Use

- In Counter Mode, the PV of the interrupt counter in the Auxiliary Area is updated every cycle as well as when the interrupt task is started. For this reason, the PV of the interrupt counter in the Auxiliary Area changes irregularly. Use the PRV(881) instruction to read the latest PV of the interrupt counter.
- Execute the following instructions to change the SV of the counter in Counter Mode.
 - If the direction is the same direction (increment/decrement), change the SV of the interrupt counter in the Auxiliary Area (A532 to A535 and A544 to A547), and then execute the MSKS(690) (SET INTERRUPT MASK) instruction in the same direction (increment/decrement) to enable interrupt inputs.
 - To change the direction from increment to decrement or decrement to increment, disable interrupt inputs with the MSKS(690) instruction. Change the SV of the interrupt counter in the Auxiliary Area, and then execute the MSKS(690) instruction to enable interrupt inputs.



Additional Information

In Counter Mode, interrupt tasks will not be started between the execution of a DI(693) instruction and the corresponding EI(694) instruction. Counting will be continued.

6-2-4 PLC Setup

Click the **Set** Button in the Interrupt Inputs and Quick-response Inputs Area on the I/O Module Tab Page of the PLC Setup. Select *Interrupt Input* for the input operation in the Interrupt Input and Quick-response Input Detailed Settings Dialog Box.

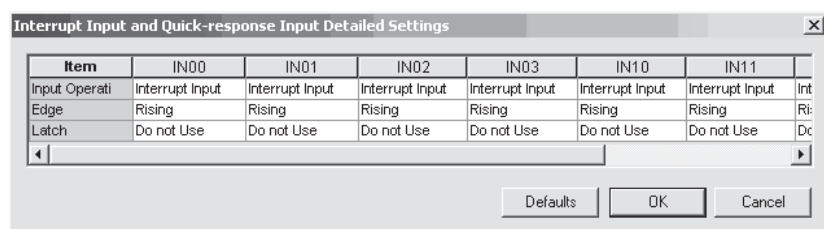
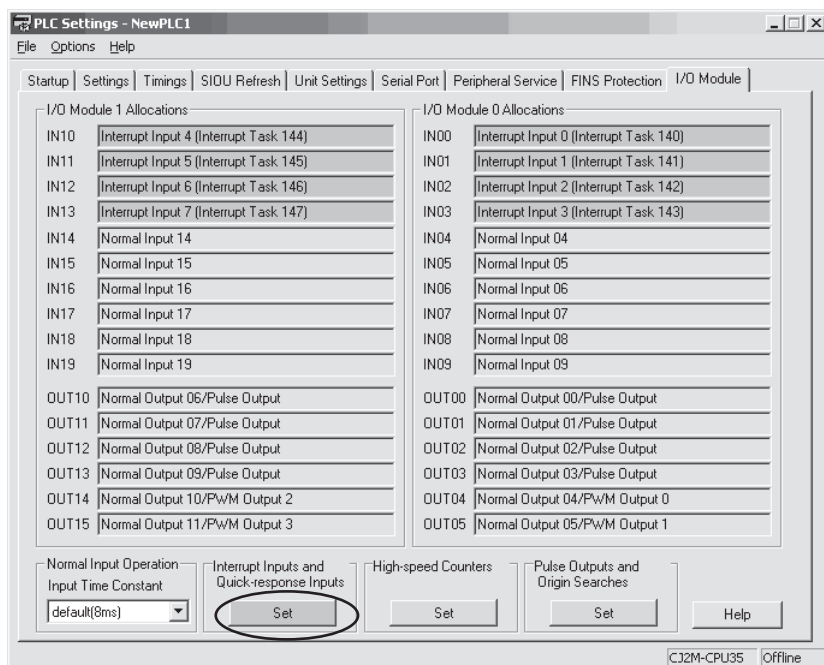

Interrupt Input and Quick-response Input Detailed Settings

Item		Setting
Interrupt inputs 0 to 7	Input Operation	Select interrupt inputs.
	Edge	Select the edge to detect to generate an interrupt input. <ul style="list-style-type: none"> • Rising Edge (ON transition) • Falling Edge (OFF transition)
	Latch	Select how to use the software latch. <ul style="list-style-type: none"> • Do not use. • Pulse output (0 to 3) • High-speed counter (0 to 3)

Specifying to Detect ON or OFF

There are the following two ways to set whether to start the interrupt on OFF transitions or ON transitions in the input.

- PLC Setup: The setting is always updated when the CPU Unit is changed from PROGRAM mode to RUN mode.
- MSKS(690) instruction: The setting can be changed during operation.

Using Software Latches

The PV of a pulse output or high-speed counter can be latched when the interrupt input that starts the interrupt task is received. The latched value is stored in the Auxiliary Area.

Pulse I/O Module No.	Terminal symbol	Corresponding bit address	Function	Interrupt task number	Latched PV storage words
0 (on the right)	IN00	CIO 2960.00	Interrupt input 0	140	A10145 (upper digits) and A10144 (lower digits)
	IN01	CIO 2960.01	Interrupt input 1	141	A10147 (upper digits) and A10146 (lower digits)
	IN02	CIO 2960.02	Interrupt input 2	142	A10149 (upper digits) and A10148 (lower digits)
	IN03	CIO 2960.03	Interrupt input 3	143	A10151 (upper digits) and A10150 (lower digits)
1 (on the left)	IN10	CIO 2962.00	Interrupt input 4	144	A10153 (upper digits) and A10152 (lower digits)
	IN11	CIO 2962.01	Interrupt input 5	145	A10155 (upper digits) and A10154 (lower digits)
	IN12	CIO 2962.02	Interrupt input 6	146	A10157 (upper digits) and A10156 (lower digits)
	IN13	CIO 2962.03	Interrupt input 7	147	A10159 (upper digits) and A10158 (lower digits)

● Application Procedure

Set the terminals to use for interrupts as interrupt inputs.

(1) Select the PV to read.

Set the edge setting in the PLC Setup to specify whether to read the PV on an ON transition or OFF transition.

(2) Execute the MSKS(690) instruction to enable the interrupt input.

Refer to page 6-11 for the settings for MSKS(690).



Additional Information

The power supply must be restarted after the PLC Setup is transferred in order to validate the software latch settings.

Applicable Input Terminals

The inputs listed in the following table can be used as interrupt inputs.

The input terminals that are used for interrupt inputs are also used for normal inputs, quick-response inputs, high-speed counter inputs, and origin search inputs. The same input terminal can be used for only one of these functions.

For example, if interrupt input 2 is used, normal input 2, the phase Z/reset method for high-speed counter 1, quick-response input 2, and the origin input signal for pulse output 1 (when performing origin searches) cannot be used.

Pulse I/O Module No.	Terminal symbol	Word	Bits	Function	Other functions that cannot be used at the same time			
					High-speed counter inputs	Normal inputs	Quick-response inputs	Origin search inputs for pulse outputs 0 to 3
0 (on the right)	IN00	CIO 2960	00	Interrupt input 0	---	Normal input 0	Quick-response input 0	Pulse output 0 origin input signal
	IN01		01	Interrupt input 1	---	Normal input 1	Quick-response input 1	Pulse output 0 origin proximity input signal
	IN02		02	Interrupt input 2	Counter 1 phase Z or reset input	Normal input 2	Quick-response input 2	Pulse output 1 origin input signal
	IN03		03	Interrupt input 3	Counter 0 phase Z or reset input	Normal input 3	Quick-response input 3	Pulse output 1 origin proximity input signal
1 (on the left)	IN10	CIO 2962	00	Interrupt input 4	---	Normal input 10	Quick-response input 4	Pulse output 2 origin input signal
	IN11		01	Interrupt input 5	---	Normal input 11	Quick-response input 5	Pulse output 2 origin proximity input signal
	IN12		02	Interrupt input 6	Counter 3 phase Z or reset input	Normal input 12	Quick-response input 6	Pulse output 3 origin input signal
	IN13		03	Interrupt input 7	Counter 0 phase Z or reset input	Normal input 13	Quick-response input 7	Pulse output 3 origin proximity input signal

6-2-5 Wiring

Connector Pin Assignments

Pulse I/O Module No. 0 (on the right)					Pulse I/O Module No. 1 (on the left)				
Input type and number	Terminal symbol	Pin	(*)	Description	Input type and number	Terminal symbol	Pin	(*)	Description
Interrupt input 0	IN00	1	A1	24-VDC input	Interrupt input 4	IN10	1	A1	24-VDC input
		5	A3	0 V			5	A3	0 V
Interrupt input 1	IN01	2	B1	24-VDC input	Interrupt input 5	IN11	2	B1	24-VDC input
		6	B3	0 V			6	B3	0 V
Interrupt input 2	IN02	7	A4	24-VDC input	Interrupt input 6	IN12	7	A4	24-VDC input
		11	A6	0 V			11	A6	0 V
Interrupt input 3	IN03	8	B4	24-VDC input	Interrupt input 7	IN13	8	B4	24-VDC input
		12	B6	0 V			12	B6	0 V

* Terminals numbers on the XW2D-□□G□ Connector-Terminal Block Conversion Unit.

6-2-6 Creating Ladder Programs

Writing the Interrupt Task's Ladder Program

Create ladder programs for interrupt tasks 140 to 147, which are executed for the corresponding interrupt inputs. Right-click the program set as the interrupt task in the CX-Programmer and select **Properties**. Select interrupt tasks 140 to 147 in the *Task Type* Field of the Program Properties Dialog Box.

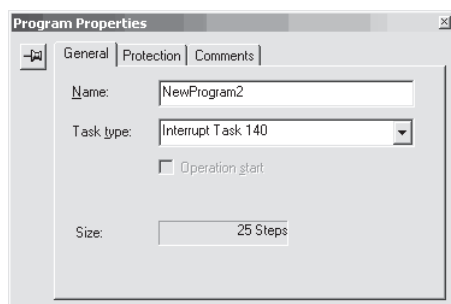

Executing MSKS(690) in a Cyclic Task

Execute the MSKS(690) instruction from the ladder program in a cyclic task to use interrupt inputs. MSKS(690) has the following two functions and two of this instruction are normally used in combination.

- (1) Specifying whether to detect ON or OFF signals.
- (2) Enabling interrupts.
 - Enabling interrupt inputs in Direct Mode
 - Enabling the interrupt input counter in Increment or Decrement Counting Mode

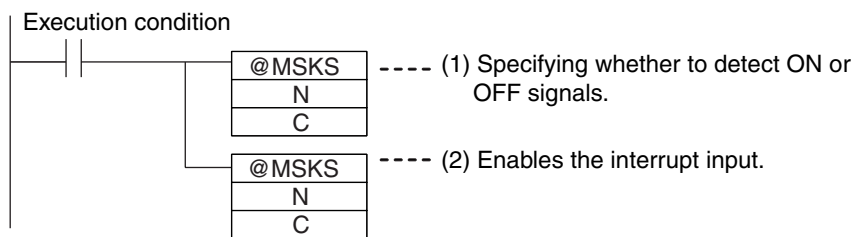

The MSKS(690) instruction must be executed only once to make the settings, so in general execute MSKS(690) in just one cycle using the upwardly differentiated variation of the instruction.

The first MSKS(690) instruction can be omitted. If it is omitted, the edge setting that is set in the PLC Setup will be used.

Specifying MSKS(690) Operands (N and C)

- (1) Specifying Whether to Detect ON or OFF Signals

Pulse I/O Module No.	Terminal symbol	Corresponding bit address	Function	Interrupt task number	Operand N	Operand C
					Interrupt identifier	Specifying to detect ON or OFF
0 (on the right)	IN00	CIO 2960.00	Interrupt input 0	140	110	#0000: Detect ON
	IN01	CIO 2960.01	Interrupt input 1	141	111	
	IN02	CIO 2960.02	Interrupt input 2	142	112	
	IN03	CIO 2960.03	Interrupt input 3	143	113	
1 (on the left)	IN10	CIO 2962.00	Interrupt input 4	144	114	#0001: Detect OFF
	IN11	CIO 2962.01	Interrupt input 5	145	115	
	IN12	CIO 2962.02	Interrupt input 6	146	116	
	IN13	CIO 2962.03	Interrupt input 7	147	117	

(2) Enabling Interrupt Inputs

Pulse I/O Module No.	Terminal symbol	Corresponding bit address	Function	Interrupt task number	Operand N	Operand C
					Interrupt identifier	Specifying to detect ON or OFF
0 (on the right)	IN00	CIO 2960.00	Interrupt input 0	140	100	#0000: Enable interrupt (Direct Mode)
	IN01	CIO 2960.01	Interrupt input 1	141	101	
	IN02	CIO 2960.02	Interrupt input 2	142	102	#0001: Disable interrupt
	IN03	CIO 2960.03	Interrupt input 3	143	103	
1 (on the left)	IN10	CIO 2962.00	Interrupt input 4	144	104	#0002: Enable interrupt (Counter Mode, decrement)
	IN11	CIO 2962.01	Interrupt input 5	145	105	
	IN12	CIO 2962.02	Interrupt input 6	146	106	#0003: Enable interrupt (Counter Mode, increment)
	IN13	CIO 2962.03	Interrupt input 7	147	107	

Example

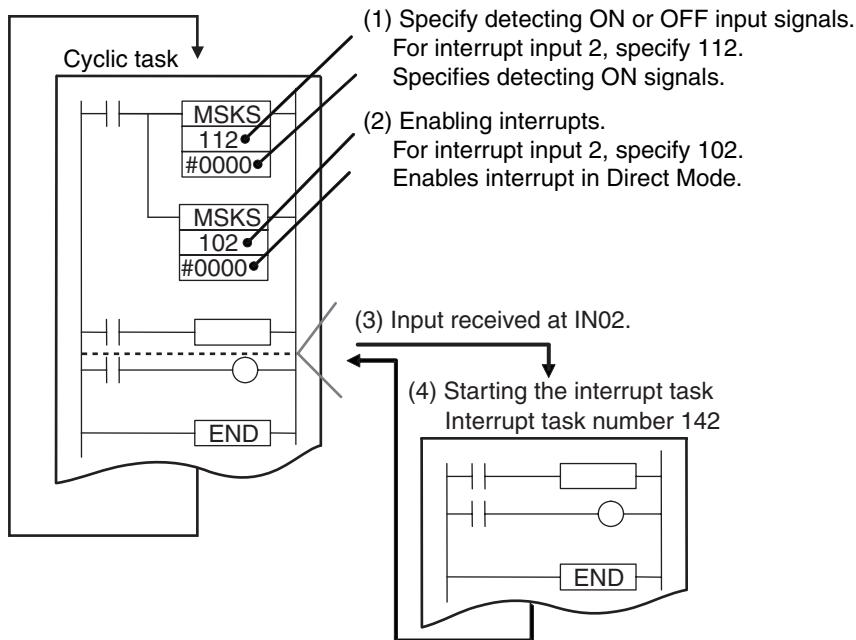

Reading the PV of an Interrupt Input Counter in Counter Mode

The present value of an interrupt input counter can be read in the following two ways.

- Reading the PV Refreshed at the I/O Refresh → Read from the Auxiliary Area. (Refer to *Related Parameters in the Auxiliary Area* on page 6-13.)
- Value updated when a ladder program is executed → Read PV by executing a PRV(881) instruction.

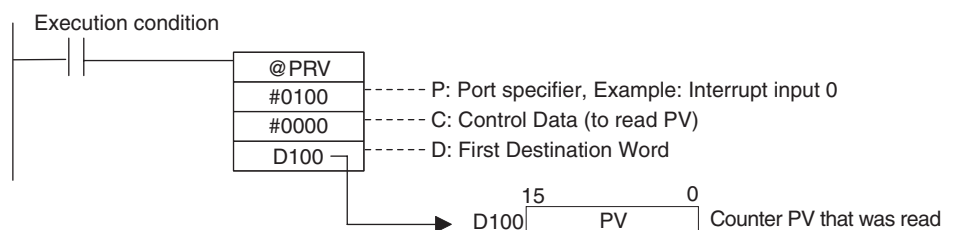

Related Parameters in the Auxiliary Area

Name	Word	Function	Read/Write	Refresh timing
Interrupt Counter 0 Counter SV	A532	This word is used for interrupt inputs in Counter Mode. Set the count value at which to start the interrupt task. When an interrupt counter (0 to 7) counts the specified number of rotations, the interrupt task (140 to 147) will be started.	Read/Write	<ul style="list-style-type: none"> Retained when power is turned ON. Retained when operation starts.
Interrupt Counter 1 Counter SV	A533			
Interrupt Counter 2 Counter SV	A534			
Interrupt Counter 3 Counter SV	A535			
Interrupt Counter 4 Counter SV	A544			
Interrupt Counter 5 Counter SV	A545			
Interrupt Counter 6 Counter SV	A546			
Interrupt Counter 7 Counter SV	A547			
Interrupt Counter 0 Counter PV	A536	These words contain the interrupt counter PVs for interrupt inputs operating in Counter Mode. When the counter reaches the counter set value in Increment Mode, the PV is automatically reset to 0. When the counter reaches 0 in Decrement Mode, the PV is automatically reset to the counter SV.	Read/Write	<ul style="list-style-type: none"> Cleared when power is turned ON. Cleared when operation starts. Refreshed every cycle. Refreshed when the interrupt task is started. Refreshed when INI(880) instruction is executed to change the PV. Preset when MSKS(690) instruction is executed to enable interrupts.
Interrupt Counter 1 Counter PV	A537			
Interrupt Counter 2 Counter PV	A538			
Interrupt Counter 3 Counter PV	A539			
Interrupt Counter 4 Counter PV	A548			
Interrupt Counter 5 Counter PV	A549			
Interrupt Counter 6 Counter PV	A550			
Interrupt Counter 7 Counter PV	A551			
Interrupt Input 0 Latched PV	A10144 and A10145	When there is an interrupt input, the PV of the pulse output or the PV of the high-speed counter input is stored. The PV immediately before the interrupt task is started is read and saved. Lower four digits: A10144, A10146, A10148, A10150, A10152, A10154, A10156, and A10158 Upper four digits: A10145, A10147, A10149 A10151, A10153, A10155, A10157, and A10159	Read	<ul style="list-style-type: none"> Cleared when power is turned ON. Refreshed when the interrupt task is started.
Interrupt Input 1 Latched PV	A10146 and A10147			
Interrupt Input 2 Latched PV	A10148 and A10149			
Interrupt Input 3 Latched PV	A10150 and A10151			
Interrupt Input 4 Latched PV	A10152 and A10153			
Interrupt Input 5 Latched PV	A10154 and A10155			
Interrupt Input 6 Latched PV	A10156 and A10157			
Interrupt Input 7 Latched PV	A10158 and A10159			

6-2-7 Application Example

In this example, bent parts are detected in a moving workpiece, such as an IC component. When the sensor input (terminal IN02, address CIO 2960.02) turns ON, the interrupt task is executed.

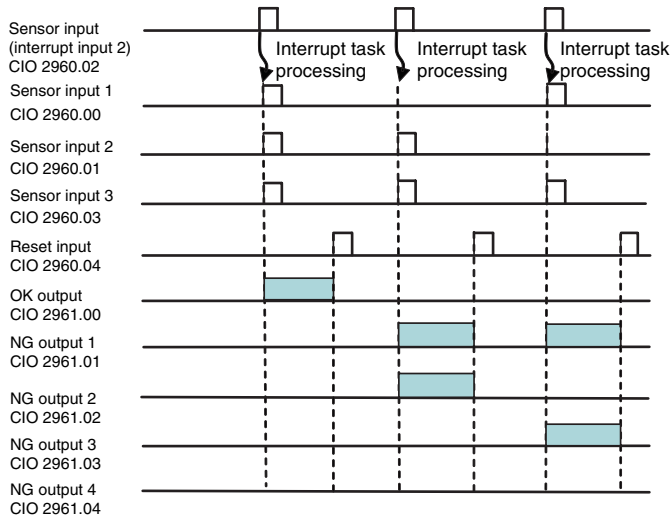
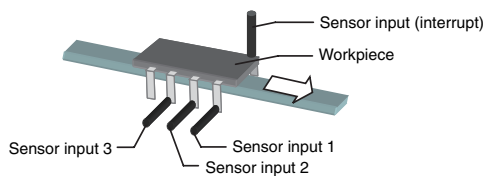

1 PLC Setup

Set IN2 to *Interrupt Input* in the Interrupt Input and Quick-response Input Detailed Settings Dialog Box that is accessed from the I/O Module Tab Page.

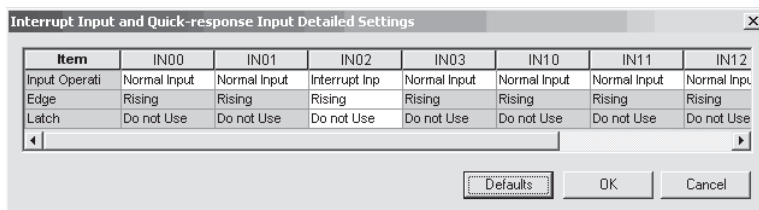

2 Connecting Interrupt Input Terminals

Terminal 2 on I/O Module 0 (CIO 2960) is interrupt input IN02.

Interrupt task 142 corresponds to interrupt input 2.

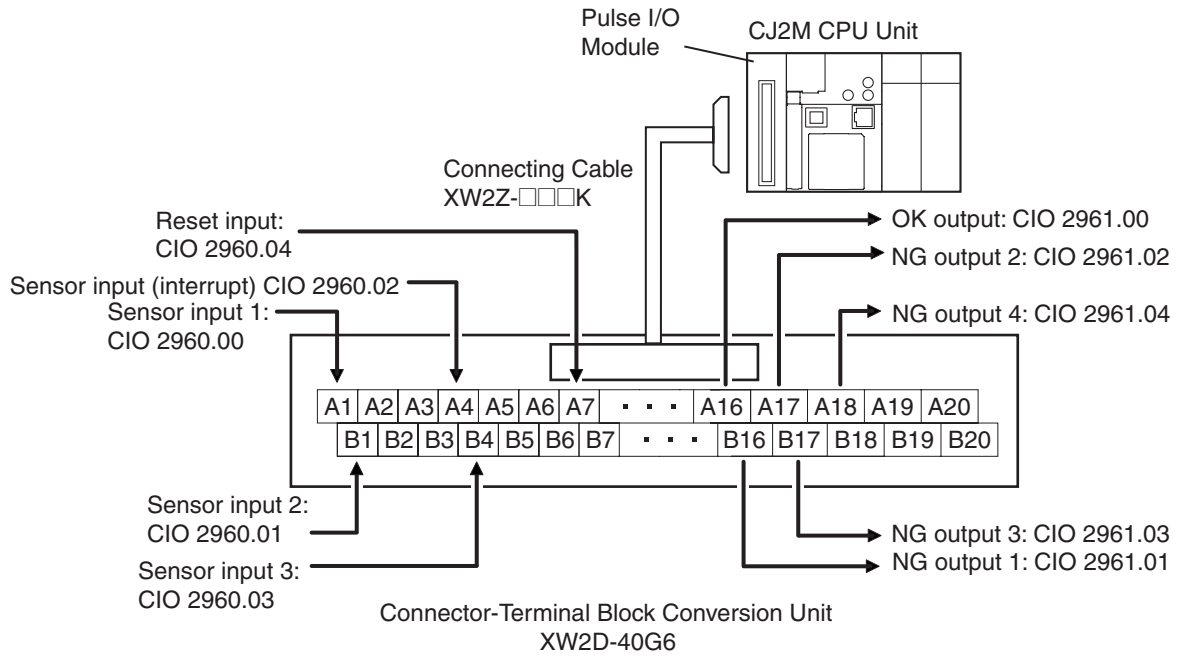

Ladder Program Example

Cyclic Task

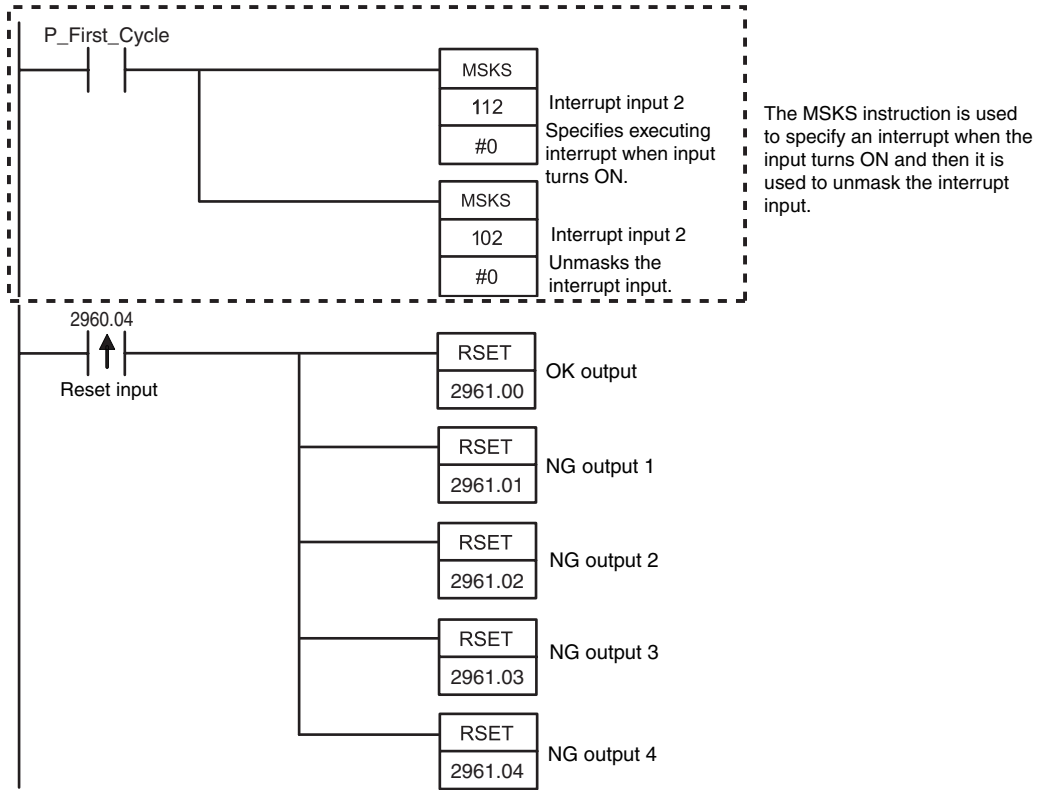

Interrupt Task 142

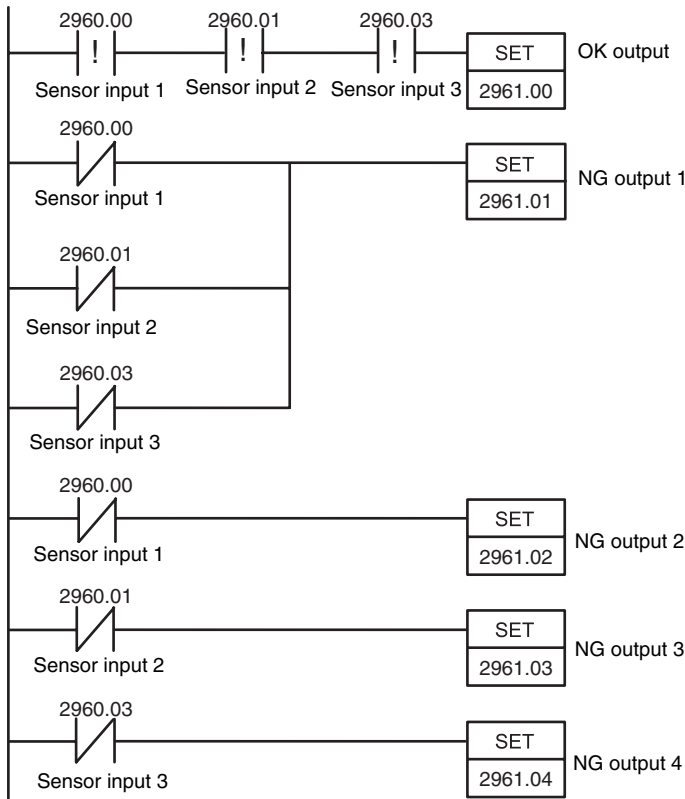



High-speed Counters

This section describes the high-speed counter inputs, high-speed counter interrupts, and the frequency measurement function.

7-1 Overview	7-2
7-1-1 Overview	7-2
7-1-2 Application Procedure	7-3
7-1-3 Specifications	7-3
7-1-4 PLC Setup	7-4
7-1-5 Wiring	7-7
7-1-6 Creating Ladder Programs	7-12
7-2 High-speed Counter Inputs	7-13
7-2-1 Pulse Input Methods Settings	7-13
7-2-2 Counting Mode Settings	7-14
7-2-3 Reset Methods	7-16
7-2-4 Reading the Present Value	7-16
7-2-5 Frequency Measurement	7-17
7-2-6 Measuring the Rotational Speed or Total Rotations	7-18
7-2-7 Reading the Count Direction	7-19
7-2-8 Temporarily Stopping Input Signal Counting (Gate Function)	7-20
7-3 High-speed Counter Interrupts	7-21
7-3-1 Overview	7-21
7-3-2 Present Value Comparison	7-25
7-3-3 High-speed Counter Interrupt Instructions	7-28
7-4 Related Auxiliary Area Words and Bits	7-35
7-5 Application Examples	7-43

7-1 Overview

7-1-1 Overview

High-speed counters are used to measure high-speed pulse input signals that cannot be measured by counter (CNT) instructions.

● Applications

- Detecting the position or length of a workpiece with an input from an incremental rotary encoder.
- Measuring the speed of a workpiece from its position data using frequency measurement and rotational speed conversion.
- High-speed processing according to the workpiece's position data.

The present value of the high-speed counter is stored in the Auxiliary Area and can be used as position data. When it reaches preset values, interrupts can be generated. The count can be started and stopped. Depending on the instruction, the frequency (speed) can be read from the present value of the high-speed counter.

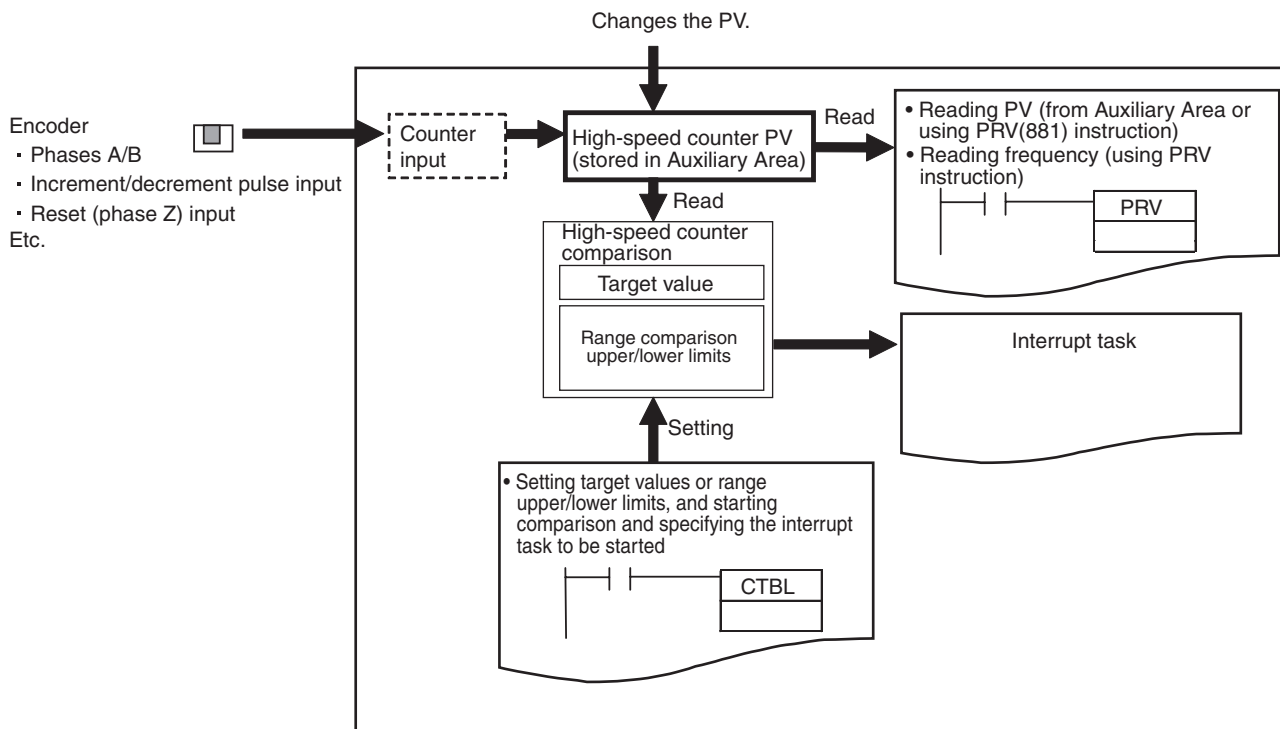

7-1-2 Application Procedure

1

PLC Setup



2

Create ladder program.	Reading counter PVs
	Reading counter frequencies

- Enable the required high-speed counters.
- Select the required input pulse frequency from the High-speed Counter Detailed Settings Dialog Box that is accessed from the I/O Module Tab Page of the PLC Setup using the CX-Programmer. Set the counting mode, reset method, pulse input mode, and other parameters.
- Input terminals IN02, IN03, IN06 to IN09, IN12, IN13, and IN16 to IN19 can be used for high-speed counters. High-speed counters 0 to 3 correspond to these.

- Read the PV from the Auxiliary Area or by executing a PRV(881) instruction.
- Execute PRV(881).

7-1-3 Specifications

Item		Description			
Pulse input method (counting mode)		Incremental pulse inputs	Differential phase input (4×)	Up/down inputs	Pulse + direction inputs
Input signals		Increment pulse	Phase A	Up pulse	Pulse
		---	Phase B	Down pulse	Direction
		---	Phase Z	Reset	Reset
Frequency and number of high-speed counters		100 kHz, 2 inputs × 2 I/O Modules	50 kHz, 2 inputs × 2 I/O Modules	100 kHz, 2 inputs × 2 I/O Modules	100 kHz, 2 inputs × 2 I/O Modules
Counting mode		Linear mode or ring mode			
Count value		Linear mode: 8000 0000 to 7FFF FFFF hex 0000 0000 to FFFF FFFF hex (for increment pulse) Ring mode: 0000 0000 to Max. ring value			
High-speed counter PV storage locations		High-speed counter 0: A271 (upper 4 digits) and A270 (lower 4 digits) High-speed counter 1: A273 (upper 4 digits) and A272 (lower 4 digits) High-speed counter 2: A317 (upper 4 digits) and A316 (lower 4 digits) High-speed counter 3: A319 (upper 4 digits) and A318 (lower 4 digits) Refreshed during overseeing processing. Use PRV(881) to read the most recent PVs. Data format: 8 digit hexadecimal • Linear mode: 8000 0000 to 7FFF FFFF hex 0000 0000 to FFFF FFFF hex (for increment pulse) • Ring mode: 0000 0000 to Max. ring value			
Control method	Target value comparison	Up to 48 target values and corresponding interrupt task numbers can be registered.			
	Range Comparison	Up to 8 or up to 32 ranges can be registered, with a separate upper limit, lower limit, and interrupt task number for each range.			
Counter reset method		• Phase-Z + Software reset The counter is reset when the phase-Z input goes ON while the Reset Bit (A531.00 to A531.03) is ON. • Software reset The counter is reset when the Reset Bit (A531.00 to A531.03) is turned ON. Operation can be set to stop or continue the comparison operation when the high-speed counter is reset.			

7-1-4 PLC Setup

Click the **I/O Module** Tab and then click the **Set** Button in the High-speed Counter Settings Area. In the High-speed Counter Detailed Settings Dialog Box, select the input pulse frequency for the *Counter setting* parameter and set the counting mode, ring counter maximum value, reset method, pulse input method, and other parameters.

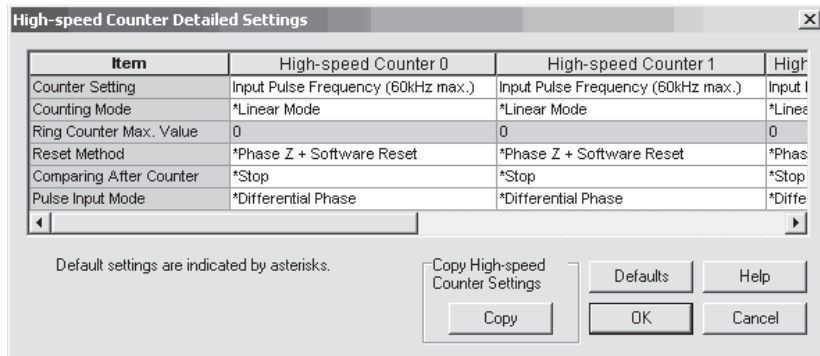
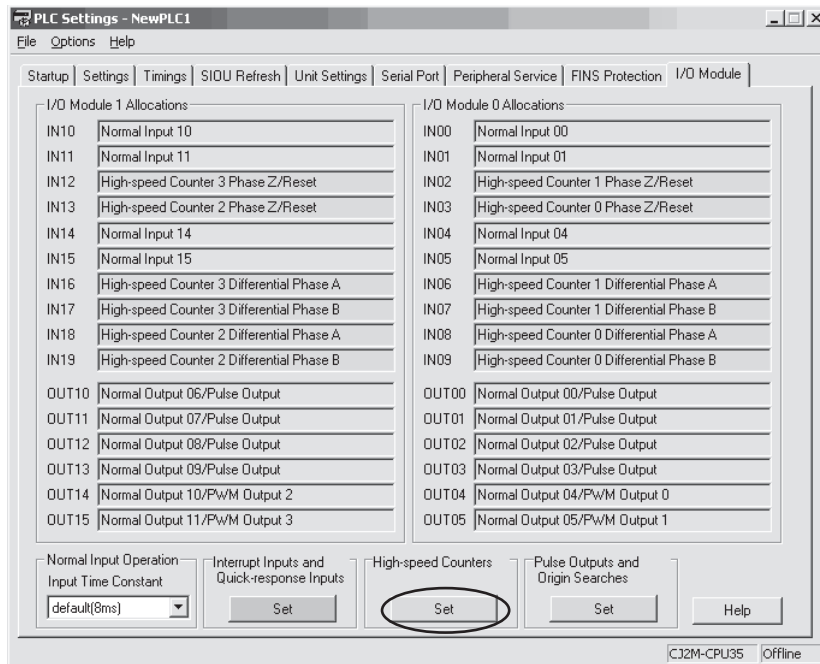

High-speed Counter Detailed Settings

Item	Setting
Use high speed counter 0 to 3.	Counter setting Select one of the following. <ul style="list-style-type: none"> • Do not use • Input pulse frequency (60 kHz max.)* • Input pulse frequency (100 kHz max.)* * The frequency of the noise filter will change.
	Counting Mode Select one of the following. <ul style="list-style-type: none"> • Linear mode • Ring mode
	Ring Counter Max. Value If a ring counter is selected, set the maximum ring count to between 0 and 4,294,967,295 decimal. (The ring counter maximum value will be 4,294,967,295 if 0 is set.)
	Reset Method Select one of the following. <ul style="list-style-type: none"> • Z phase, software reset • Software reset
	Comparing After Counter Reset Select one of the following. <ul style="list-style-type: none"> • Stop • Continue
	Pulse Input Mode Select one of the following. <ul style="list-style-type: none"> • Differential Phase • Pulse + Direction • Up/Down pulse • Increment pulse

Note The power supply must be restarted after the PLC Setup is transferred in order to enable the high-speed counter settings.

Determining High-speed Counters

● Applicable Input Terminals

Terminals that can be used as high-speed counter inputs are shown in the following table.

The terminals that are used for high-speed counter inputs are also used for normal inputs, quick-response inputs, interrupt inputs, and origin searches. The same input terminal can be used for only one of these functions.

For example, if high-speed counter 1 is used, interrupt input 2, normal input 2, normal input 6, normal input 7, quick-response input 2, and origin input signal for pulse output 1 (when performing origin searches) cannot be used.

Pulse I/O Module No.	Terminal symbol	Word	Bits	High-speed counter pulse input mode				Other functions that cannot be used at the same time			
				Differential phase	Pulse + direction	Up/Down	Increment pulse	Interrupt inputs	Normal inputs	Quick-response inputs	Origin search inputs for pulse outputs 0 to 3
0 (on the right)	IN02	CIO 2960	02	High-speed counter 1 phase Z	High-speed counter 1 reset	High-speed counter 1 reset	High-speed counter 1 reset	Interrupt input 2	Normal input 2	Quick-response input 2	Pulse output 1 origin input signal
	IN03		03	High-speed counter 0 phase Z	High-speed counter 0 reset	High-speed counter 0 reset	High-speed counter 0 reset	Interrupt input 3	Normal input 3	Quick-response input 3	Pulse output 1 origin proximity input signal
	IN06		06	High-speed counter 1 phase A	High-speed counter 1 count	High-speed counter 1 increment	High-speed counter 1 count	---	Normal input 6	---	---
	IN07		07	High-speed counter 1 phase B	High-speed counter 1 direction	High-speed counter 1 decrement	Normal input 7	---	Normal input 7	---	---
	IN08		08	High-speed counter 0 phase A	High-speed counter 0 count	High-speed counter 0 increment	High-speed counter 0 count	---	Normal input 8	---	---
	IN09		09	High-speed counter 0 phase B	High-speed counter 0 direction	High-speed counter 0 decrement	Normal input 9	---	Normal input 9	---	---
1 (on the left)	IN12	CIO 2962	02	High-speed counter 3 phase Z	High-speed counter 3 reset	High-speed counter 3 reset	High-speed counter 3 reset	Interrupt input 6	Normal input 12	Quick-response input 6	Pulse output 3 origin input signal
	IN13		03	High-speed counter 2 phase Z	High-speed counter 2 reset	High-speed counter 2 reset	High-speed counter 2 reset	Interrupt input 7	Normal input 13	Quick-response input 7	Pulse output 3 origin proximity input signal
	IN16		06	High-speed counter 3 phase A	High-speed counter 3 count	High-speed counter 3 increment	High-speed counter 3 count	---	Normal input 16	---	---
	IN17		07	High-speed counter 3 phase B	High-speed counter 3 direction	High-speed counter 3 decrement	Normal input 17	---	Normal input 17	---	---
	IN18		08	High-speed counter 2 phase A	High-speed counter 2 count	High-speed counter 2 increment	High-speed counter 2 count	---	Normal input 18	---	---
	IN19		09	High-speed counter 2 phase B	High-speed counter 2 direction	High-speed counter 2 decrement	Normal input 19	---	Normal input 19	---	---

7-1-5 Wiring

Connector Pin Assignments

● Phase Inputs

Pulse I/O Module No. 0 (on the right)						Pulse I/O Module No. 1 (on the left)					
Input type and number	Terminal symbol	Pin	(*1)	Description*2		Input type and number	Terminal symbol	Pin	(*1)	Description*2	
				OC	LD					OC	LD
High-speed counter 0	IN08	25	A13	Phase-A input 24 V	---	High-speed counter 2	IN18	25	A13	Phase-A input 24 V	---
		27	A14	---	Phase-A LD+			27	A14	---	Phase-A LD+
		29	A15	Phase-A input 0 V	Phase-A LD-			29	A15	Phase-A input 0 V	Phase-A LD-
	IN09	26	B13	Phase-B input 24 V	---		IN19	26	B13	Phase-B input 24 V	---
		28	B14	---	Phase-B LD+			28	B14	---	Phase-B LD+
		30	B15	Phase-B 0V	Phase-B LD-			30	B15	Phase-B 0V	Phase-B LD-
	IN03	8	B4	Phase-Z input 24 V	---		IN13	8	B4	Phase-Z input 24 V	---
		10	B5	---	Phase-Z LD+			10	B5	---	Phase-Z LD+
		12	B6	Phase-Z input 0 V	Phase-Z LD-			12	B6	Phase-Z input 0 V	Phase-Z LD-
High-speed counter 1	IN06	19	A10	Phase-A input 24 V	---	High-speed counter 3	IN16	19	A10	Phase-A input 24 V	---
		21	A11	---	Phase-A LD+			21	A11	---	Phase-A LD+
		23	A12	Phase-A input 0 V	Phase-A LD-			23	A12	Phase-A input 0 V	Phase-A LD-
	IN07	20	B10	Phase-B input 24 V	---		IN17	20	B10	Phase-B input 24 V	---
		22	B11	---	Phase-B LD+			22	B11	---	Phase-B LD+
		24	B12	Phase-B input 0 V	Phase-B LD-			24	B12	Phase-B input 0 V	Phase-B LD-
	IN02	7	A4	Phase-Z input 24 V	---		IN12	7	A4	Phase-Z input 24 V	---
		9	A5	---	Phase-Z LD+			9	A5	---	Phase-Z LD+
		11	A6	Phase-Z input 0 V	Phase-Z LD-			11	A6	Phase-Z input 0 V	Phase-Z LD-

*1 Terminals numbers on the XW2D-□□G□ Connector-Terminal Block Conversion Unit.

*2 OC: Use these connections for a device with open-collector outputs. LD: Use these connections for a device with line-driver outputs.

● Pulse + Direction Inputs

Pulse I/O Module No. 0 (on the right)						Pulse I/O Module No. 1 (on the left)					
Input type and number	Terminal symbol	Pin	(*1)	Description*2		Input type and number	Terminal symbol	Pin	(*1)	Description*2	
				OC	LD					OC	LD
High-speed counter 0	IN08	25	A13	Counter input 24 V	---	High-speed counter 2	IN18	25	A13	Counter input 24 V	---
		27	A14	---	Count input LD+			27	A14	---	Count input LD+
		29	A15	Counter input 0 V	Count input LD-			29	A15	Counter input 0 V	Count input LD-
	IN09	26	B13	Direction input 24 V	---		IN19	26	B13	Direction input 24 V	---
		28	B14	---	Direction input LD+			28	B14	---	Direction input LD+
		30	B15	Direction input 0 V	Direction input LD-			30	B15	Direction input 0 V	Direction input LD-
	IN03	8	B4	Reset input 24 V	---		IN13	8	B4	Reset input 24 V	---
		10	B5	---	Reset input LD+			10	B5	---	Reset input LD+
		12	B6	Reset input 0 V	Reset input LD-			12	B6	Reset input 0 V	Reset input LD-
High-speed counter 1	IN06	19	A10	Counter input 24 V	---	High-speed counter 3	IN16	19	A10	Counter input 24 V	---
		21	A11	---	Count input LD+			21	A11	---	Count input LD+
		23	A12	Counter input 0 V	Count input LD-			23	A12	Counter input 0 V	Count input LD-
	IN07	20	B10	Direction input 24 V	---		IN17	20	B10	Direction input 24 V	---
		22	B11	---	Direction input LD+			22	B11	---	Direction input LD+
		24	B12	Direction input 0 V	Direction input LD-			24	B12	Direction input 0 V	Direction input LD-
	IN02	7	A4	Reset input 24 V	---		IN12	7	A4	Reset input 24 V	---
		9	A5	---	Reset input LD+			9	A5	---	Reset input LD+
		11	A6	Reset input 0 V	Reset input LD-			11	A6	Reset input 0 V	Reset input LD-

*1 Terminals numbers on the XW2D-□□G□ Connector-Terminal Block Conversion Unit.

*2 OC: Use these connections for a device with open-collector outputs. LD: Use these connections for a device with line-driver outputs.

● Up/Down Pulse Inputs

Pulse I/O Module No. 0 (on the right)						Pulse I/O Module No. 1 (on the left)					
Input type and number	Terminal symbol	Pin	(*1)	Description*2		Input type and number	Terminal symbol	Pin	(*1)	Description*2	
				OC	LD					OC	LD
High-speed counter 0	IN08	25	A13	Up input 24 V	---	High-speed counter 2	IN18	25	A13	Up input 24 V	---
		27	A14	---	Up input LD+			27	A14	---	Up input LD+
		29	A15	Up input 0 V	Up input LD-			29	A15	Up input 0 V	Up input LD-
	IN09	26	B13	Down input 24 V	---		IN19	26	B13	Down input 24 V	---
		28	B14	---	Down input LD+			28	B14	---	Down input LD+
		30	B15	Down input 0 V	Down input LD-			30	B15	Down input 0 V	Down input LD-
	IN03	8	B4	Reset input 24 V	---		IN13	8	B4	Reset input 24 V	---
		10	B5	---	Reset input LD+			10	B5	---	Reset input LD+
		12	B6	Reset input 0 V	Reset input LD-			12	B6	Reset input 0 V	Reset input LD-
High-speed counter 1	IN06	19	A10	Up input 24 V	---	High-speed counter 3	IN16	19	A10	Up input 24 V	---
		21	A11	---	Up input LD+			21	A11	---	Up input LD+
		23	A12	Up input 0 V	Up input LD-			23	A12	Up input 0 V	Up input LD-
	IN07	20	B10	Down input 24 V	---		IN17	20	B10	Down input 24 V	---
		22	B11	---	Down input LD+			22	B11	---	Down input LD+
		24	B12	Down input 0 V	Down input LD-			24	B12	Down input 0 V	Down input LD-
	IN02	7	A4	Reset input 24 V	---		IN12	7	A4	Reset input 24 V	---
		9	A5	---	Reset input LD+			9	A5	---	Reset input LD+
		11	A6	Reset input 0 V	Reset input LD-			11	A6	Reset input 0 V	Reset input LD-

*1 Terminals numbers on the XW2D-□□G□ Connector-Terminal Block Conversion Unit.

*2 OC: Use these connections for a device with open-collector outputs. LD: Use these connections for a device with line-driver outputs.

● Increment Pulse Input

Pulse I/O Module No. 0 (on the right)						Pulse I/O Module No. 1 (on the left)					
Input type and number	Terminal symbol	Pin	(*1)	Description*2		Input type and number	Terminal symbol	Pin	(*1)	Description*2	
				OC	LD					OC	LD
High-speed counter 0	IN08	25	A13	Increment input 24 V	---	High-speed counter 2	IN18	25	A13	Increment input 24 V	---
		27	A14	---	Increment input LD+			---	Increment input LD+		
		29	A15	Increment input 0 V	Increment input LD-			29	A15	Increment input 0 V	Increment input LD-
	IN03	8	B4	Reset input 24 V	---		IN13	8	B4	Reset input 24 V	---
		10	B5	---	Reset input LD+			10	B5	---	Reset input LD+
		12	B6	Reset input 0 V	Reset input LD-			12	B6	Reset input 0 V	Reset input LD-
High-speed counter 1	IN06	19	A10	Increment input 24 V	---	High-speed counter 3	IN16	19	A10	Increment input 24 V	---
		21	A11	---	Increment input LD+			21	A11	---	Increment input LD+
		23	A12	Increment input 0 V	Increment input LD-			23	A12	Increment input 0 V	Increment input LD-
	IN02	7	A4	Reset input 24 V	---		IN12	7	A4	Reset input 24 V	---
		9	A5	---	Reset input LD+			9	A5	---	Reset input LD+
		11	A6	Reset input 0 V	Reset input LD-			11	A6	Reset input 0 V	Reset input LD-

*1 Terminals numbers on the XW2D-□□G□ Connector-Terminal Block Conversion Unit.

*2 OC: Use these connections for a device with open-collector outputs. LD: Use these connections for a device with line-driver outputs.

Wiring Example

The following example shows the connections of an encoder with phase-A, phase-B, and phase-Z inputs to high-speed counter 0.

Using a 24-VDC Open-collector Encoder

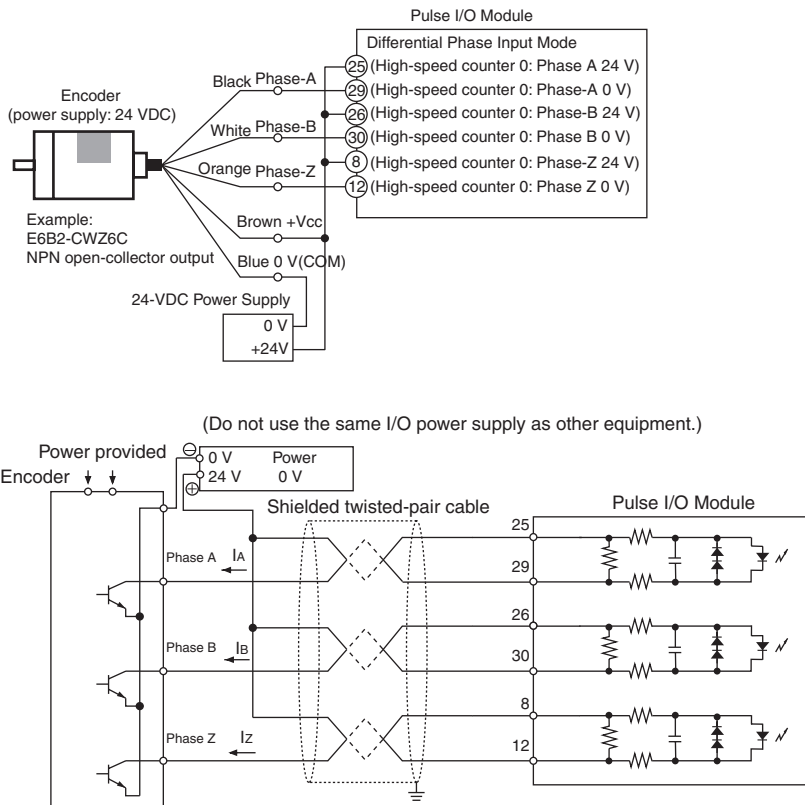

Encoders with Line Driver Outputs (Conforming to AM26LS31)

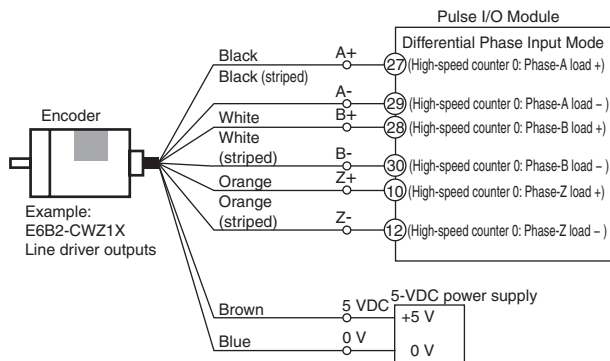

(Do not use the same I/O power supply as other equipment.)

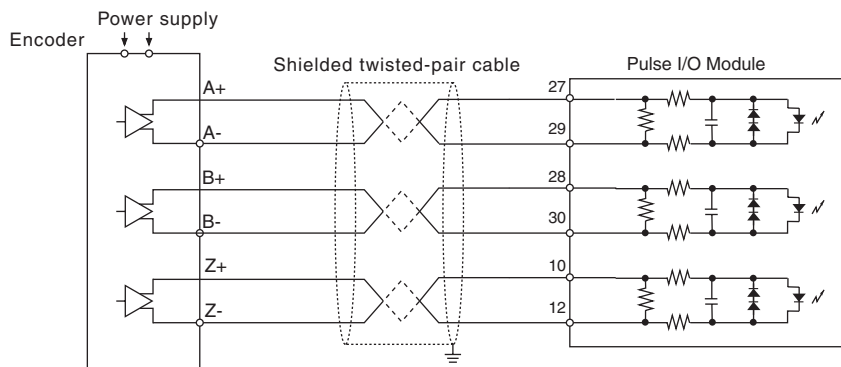

7-1-6 Creating Ladder Programs

Execution	Program	Reference
Generating interrupts for the high-speed counter PV (number of pulses) and perform high-speed processing.	Specify interrupt tasks with CTBL(882) instructions.	7-3 High-speed Counter Interrupts
Reading the high-speed counter PV (number of pulses).	Read the high-speed counter PV from the Auxiliary Area or using the PRV(881) instruction and convert it to position or length data using instructions or measure the length using comparison instructions such as =, <, and >.	7-2-4 Reading the Present Value
Reading the high-speed counter frequency (speed).	Execute a PRV(881) instruction.	7-2-5 Frequency Measurement
Reading the rotational speed or total number of pulses from the high-speed counter input	Execute a PRV2(883) instruction.	7-2-6 Measuring the Rotational Speed or Total Rotations
Changing or reading the PV of the high-speed counter when an interrupt input occurs	Use the software latch to write the PV of the high-speed counter just before the interrupt task is executed to the Auxiliary Area.	<i>Using Software Latches</i> on page 6-8
Reading the direction of the high-speed counter	Read the high-speed counter direction from the Auxiliary Area or by executing the PRV(881) instruction to read status.	7-2-7 Reading the Count Direction

7-2 High-speed Counter Inputs

7-2-1 Pulse Input Methods Settings

There are four pulse input methods for high-speed counters.

- Increment pulse input
- Differential phase inputs (4×)
- Up/down pulse inputs
- Pulse + direction inputs

Increment Pulse Input

The increment pulse input method counts signals on a single-phase pulse input. Only incrementing the count is possible in this mode.

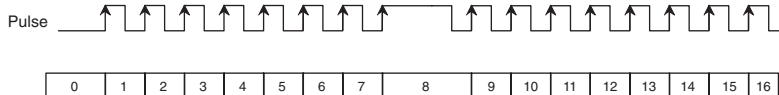

Conditions for Incrementing/Decrementing the Count

Pulse	Count value
OFF→ON	Incremented
ON	No change
ON→OFF	No change
OFF	No change

• Only rising edges are counted.

Differential Phase Inputs (4×)

The differential phase input method uses two phase signals (phase A and phase B) and increments/decrements the count according to the status of Differential Phase (4×).

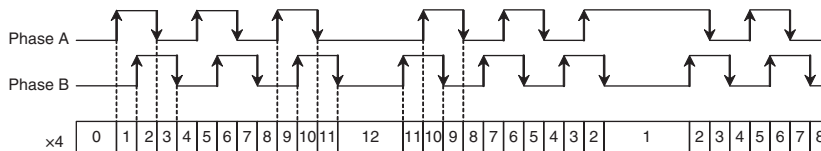

Conditions for Incrementing/Decrementing the Count

Phase A	Phase B	Count value
OFF→ON	OFF	Incremented
ON	OFF→ON	Incremented
ON→OFF	ON	Incremented
OFF	ON→OFF	Incremented
OFF	OFF→ON	Decrement
OFF→ON	ON	Decrement
ON	ON→OFF	Decrement
ON→OFF	OFF	Decrement

Up/Down Pulse Inputs

The up/down pulse input method uses two signals, an increment pulse and a decrement pulse.

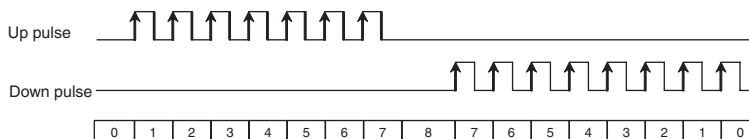

Conditions for Incrementing/Decrementing the Count

Down pulse	Up pulse	Count value
OFF→ON	OFF	Decrement
ON	OFF→ON	Incremented
ON→OFF	ON	No change
OFF	ON→OFF	No change
OFF	OFF→ON	Incremented
OFF→ON	ON	Decrement
ON	ON→OFF	No change
ON→OFF	OFF	No change

• The count is incremented for each increment pulse and decremented for each decrement pulse.

• Only rising edges are counted.

Pulse + Direction Inputs

The pulse + direction input method uses a direction signal and a pulse signal. The count is incremented or decremented depending on the status (ON or OFF) of the direction signal.

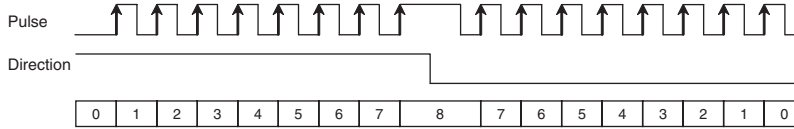

Conditions for Incrementing/Decrementing the Count

Direction	Pulse	Count value
OFF→ON	OFF	No change
ON	OFF→ON	Incremented
ON→OFF	ON	No change
OFF	ON→OFF	No change
OFF	OFF→ON	Decrementd
OFF→ON	ON	No change
ON	ON→OFF	No change
ON→OFF	OFF	No change

- The count is incremented when the direction signal is ON and decremented when it is OFF.
- Only rising edges are counted.



Additional Information

The count of a high-speed counter can be monitored to see if it is currently being incremented or decremented. The count direction can be read from the Auxiliary Area. The count in the current cycle is compared with the count in the previous cycle to determine if it is being incremented or decremented.

The results are reflected in the High-speed Counter Count Direction Flags.

Pulse I/O Module No.	High-speed counter	Address of High-speed Counter Count Direction Flag
0 (on the right)	High-speed counter 0	A274.10
	High-speed counter 1	A275.10
1 (on the left)	High-speed counter 2	A320.10
	High-speed counter 3	A321.10

The counter direction can also be monitored by using the PRV(881) instruction to read counter status.

7-2-2 Counting Mode Settings

The following counting modes can be selected for high-speed counters: Linear Mode, which counts in a fixed range, and Ring Mode, which counts in a set range to a specified maximum value.

Linear Mode

Input pulses can be counted in the range between the lower limit and upper limit values. If the pulse count goes beyond the lower/upper limit, an underflow/overflow will occur and counting will stop.

- Increment Mode



- Up/Down Mode

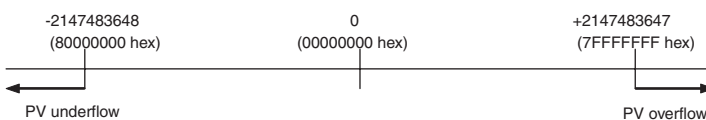

Ring Mode

Input pulses are counted in a loop within the set range.

- If the count is incremented from the maximum ring count, the count will be reset to 0 automatically and incrementing will continue.
- If the count is decremented from 0, the count will be set to the maximum ring count automatically and decrementing will continue.

Consequently, underflows and overflows cannot occur when Ring Mode is used.

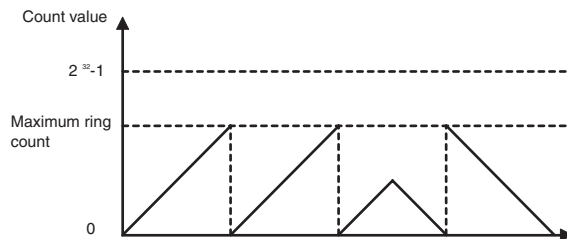

● Ring Counter Maximum Value

The maximum value of the counting range for the input pulses can be set in the PLC Setup or by executing the INI(880) instruction to change the maximum ring count.

The maximum ring count can be set to any value between 0000 0001 and FFFF FFFF hex (1 to 4,294,967,295 decimal).

The values that are set will be stored in the following words.

Pulse I/O Module No.	Set value	Auxiliary Area words
0 (on the right)	High-speed Counter 0 Ring Counter Maximum Value	A10137 (upper digits) and A10136 (lower digits)
	High-speed Counter 1 Ring Counter Maximum Value	A10139 (upper digits) and A10138 (lower digits)
1 (on the left)	High-speed Counter 2 Ring Counter Maximum Value	A10141 (upper digits) and A10140 (lower digits)
	High-speed Counter 3 Ring Counter Maximum Value	A10143 (upper digits) and A10142 (lower digits)



Precautions for Correct Use

- There are no negative values in Ring Mode.
- If the maximum ring count is set to 0, the counter will operate with a ring counter maximum value of FFFF FFFF hex.
- The ring counter maximum value cannot be changed while the comparison operation is in progress.
- If a value that exceeds the ring counter maximum value is registered in the comparison table, the comparison operation will not started.
- When the ring counter maximum value is changed, the PV of the high-speed counter will be cleared to 0.



Additional Information

If necessary, execute the INI(880) instruction to change the ring counter maximum value.

7-2-3 Reset Methods

Setting a high-speed counter's PV to 0 is called resetting.

There are two reset methods.

- Phase-Z Signal + Software Reset
- Software Reset

Phase-Z Signal + Software Reset

The high-speed counter's PV is reset when the phase-Z signal (reset input) turns ON while the corresponding High-speed Counter Reset Bit (A531.00 to A531.03) is ON.

The CPU Unit recognizes the ON status of the High-speed Counter Reset Bit only at the beginning of the PLC cycle during the overseeing processes. Consequently, when the Reset Bit is turned ON in the ladder program, the phase-Z signal does not become effective until the next PLC cycle.

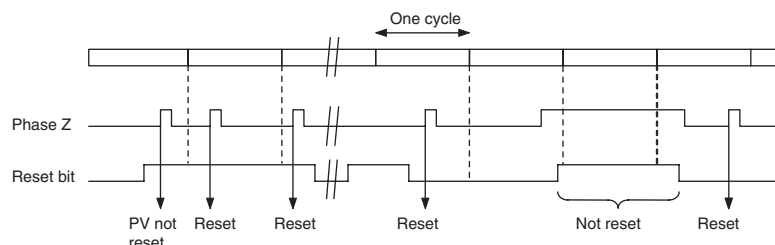

Software Reset

The high-speed counter's PV is reset when the corresponding High-speed Counter Reset Bit (A531.00 to A531.03) turns ON.

The CPU Unit recognizes the OFF-to-ON transition of the High-speed Counter Reset Bit only at the beginning of the PLC cycle during the overseeing processes. Reset processing is performed at the same time. The OFF-to-ON transition will not be recognized if the Reset Bit turns OFF again within the same cycle.

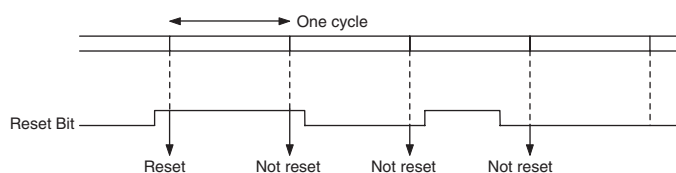

Additional Information

The comparison operation can be set to stop or continue when a high-speed counter is reset. This enables applications where the comparison operation can be restarted from a counter PV of 0 when the counter is reset.

7-2-4 Reading the Present Value

The present value of a high-speed counter can be read in the following three ways.

- Value refreshed at the I/O refresh timing → Read PV from Auxiliary Area.
- Value updated when a ladder program is executed → Read PV by executing a PRV(881) instruction.
- PV when an interrupt input occurs → Use the software latch and read the value from the Auxiliary Area.

Reading the PV Refreshed at the I/O Refresh Timing

The PV that is stored in the following words can be read using the MOVL(498) instruction or other instructions.

Pulse I/O Module No.	Read PV	Auxiliary Area words
0 (on the right)	High-speed counter 0	A271 (upper digits) and A270 (lower digits)
	High-speed counter 1	A273 (upper digits) and A272 (lower digits)
1 (on the left)	High-speed counter 2	A317 (upper digits) and A316 (lower digits)
	High-speed counter 3	A319 (upper digits) and A318 (lower digits)

Reading the Value When a Ladder Program is Executed

● Reading the High-speed Counter PV with a PRV(881) Instruction

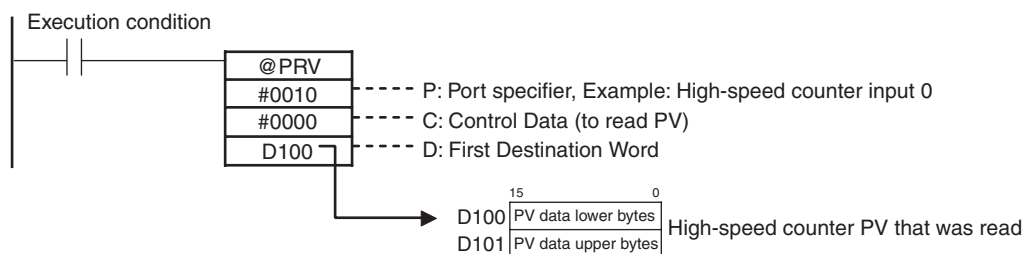

Reading the PV When there Is an Interrupt Input

LPV(893) reads the PV of the high-speed counter each time an interrupt input occurs and stores the value in the Auxiliary Area.

It reads the PV immediately before the interrupt task is started. LPV(893) reads the PV more in real-time than starting an interrupt task and using the PRV(881) instruction to read the PV.

Refer to *Using Software Latches* on page 6-8.

7-2-5 Frequency Measurement

Overview

This function measures the frequency of the high-speed counter (input pulses.)

The input pulse frequency can be read by executing the PRV(881) instruction. The measured frequency is output in 8-digit hexadecimal and expressed in Hz. The frequency measurement function can be used with high-speed counter 0 only.

The frequency can be measured while a high-speed counter 0 comparison operation is in progress. Frequency measurement can be performed at the same time as functions such as the high-speed counter and pulse output without affecting the performance of those functions.

● **Reading the High-speed Counter Frequency with a PRV(881) Instruction**

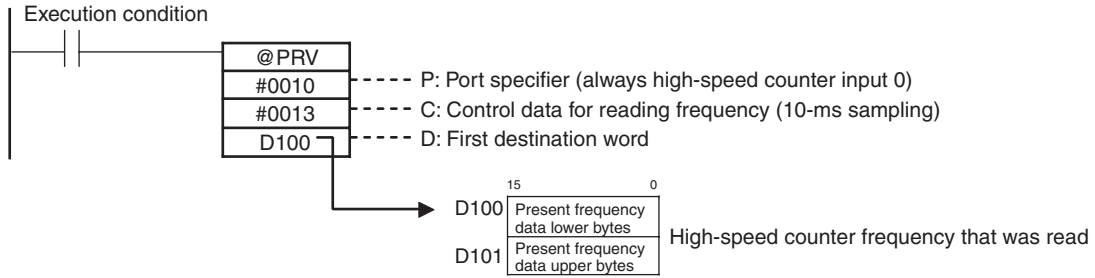

Precautions for Correct Use

The frequency measurement function can be used with high-speed counter 0 only.

● **Specifications**

Item		Description
Number of frequency measurement inputs		1 input (high-speed counter 0 only)
Frequency measurement range		Differential phase input: 0 to 50 kHz* All other input modes: 0 to 100 kHz*
Measurement method		Execution of the PRV(881) instruction
Stored data	Unit	Hz
	Output data range	Differential phase input: 0000 0000 to 0003 0D40 hex All other input modes: 0000 0000 to 0001 86A0 hex

* If the frequency exceeds the maximum value, the maximum value will be stored.

7-2-6 Measuring the Rotational Speed or Total Rotations

The rotational speed (rotations) or the total number of rotations can be measured.

● **Measuring the Rotational Speed**

The speed in r/min is calculated from the pulse frequency and the set number of pulses per rotation. Execute the PRV2(883) instruction and specify converting the frequency to a rotational speed.

● **Measuring the Total Rotations**

The total number of rotations is calculated from the counter's PV and the set number of pulses per rotation. Execute the PRV2(883) instruction and specify converting the counter's PV to the total number of revolutions.

● **PRV2(883) (PULSE FREQUENCY CONVERT) Instruction**

● **Measuring the Rotational Speed**

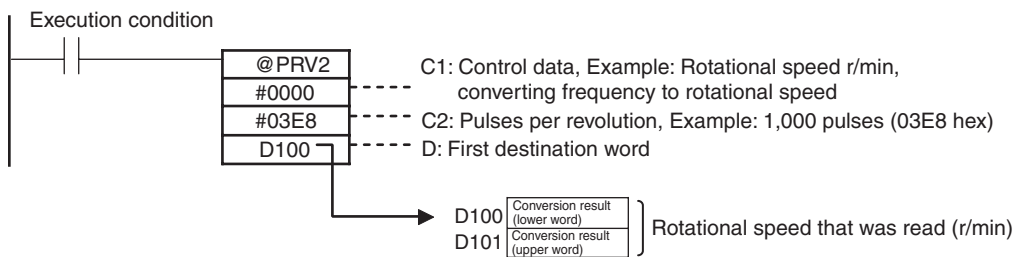

• Measuring Total Number of Revolutions

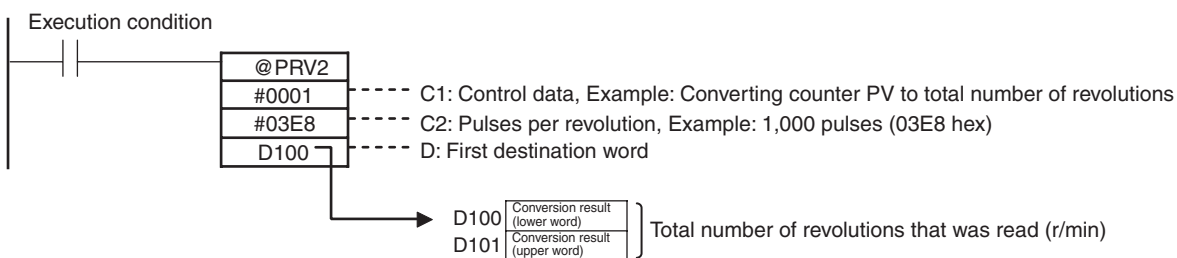

Precautions for Correct Use

Measuring the rotational speed or total number of revolutions can be performed with high-speed counter 0 only.

7-2-7 Reading the Count Direction

The count direction of a high-speed counter that was stored during the I/O refresh can be read from the Auxiliary Area.

Reading the PV Refreshed at the I/O Refresh Timing

The PV that is stored in the following words can be read using the MOVL(498) instruction or other instructions.

Pulse I/O Module No.	Read value	Auxiliary Area bit	
0 (on the right)	High-speed Counter 0 Count Direction	A274.10	OFF: Decrementing ON: Incrementing
	High-speed Counter 1 Count Direction	A275.10	
1 (on the left)	High-speed Counter 2 Count Direction	A320.10	
	High-speed Counter 3 Count Direction	A321.10	

Reading the Value from the Ladder Program

● Reading the High-speed Counter Status with a PRV(881) Instruction

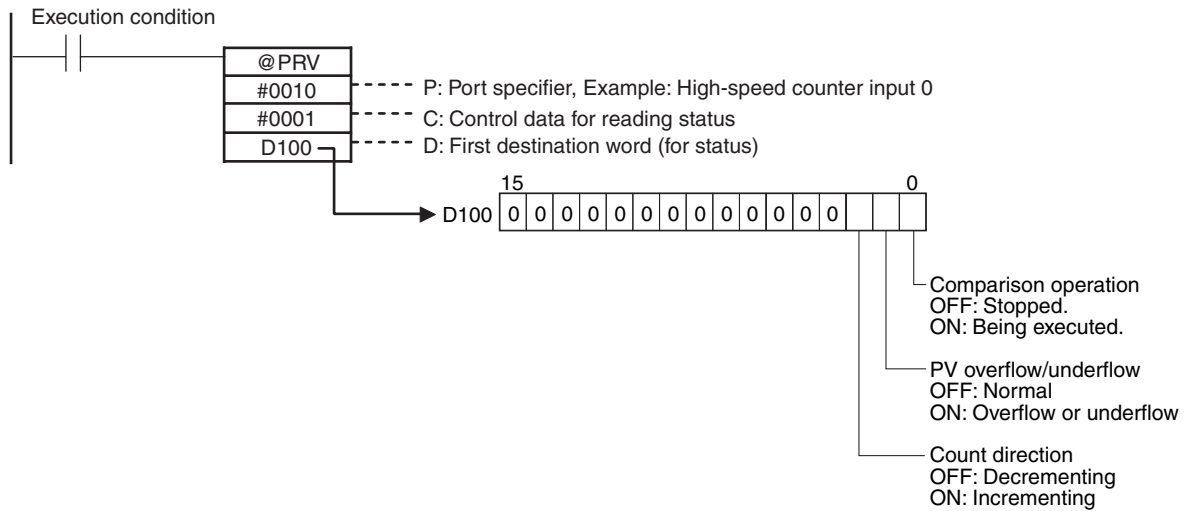

7-2-8 Temporarily Stopping Input Signal Counting (Gate Function)

If a Gate Bit (A531.08 to A531.11) of a high-speed counter 0 to 3 is turned ON, the high-speed counter will not count even if pulse inputs are received and the counter PV will be maintained at its current value. When the Gate Bit of the high-speed counter is turned OFF again, the high-speed counter will resume counting and the counter PV will be refreshed.



Precautions for Correct Use

The Gate Bit will be disabled if the high-speed counter reset method is set to a phase-Z signal + software reset and the Reset Bit is ON (i.e., waiting for the phase-Z input to reset the counter PV.)



Additional Information

Even if a Gate Bit is ON, the INI(880) instruction can be used to change the PV or execute a software reset.

7-3 High-speed Counter Interrupts

7-3-1 Overview

A high-speed counter interrupt counts input pulses with the built-in high-speed counter and executes an interrupt task when the count reaches the preset value or falls within a preset range (target-value or range comparison). An interrupt task between 0 and 255 can be allocated with the CTBL(882) instruction.

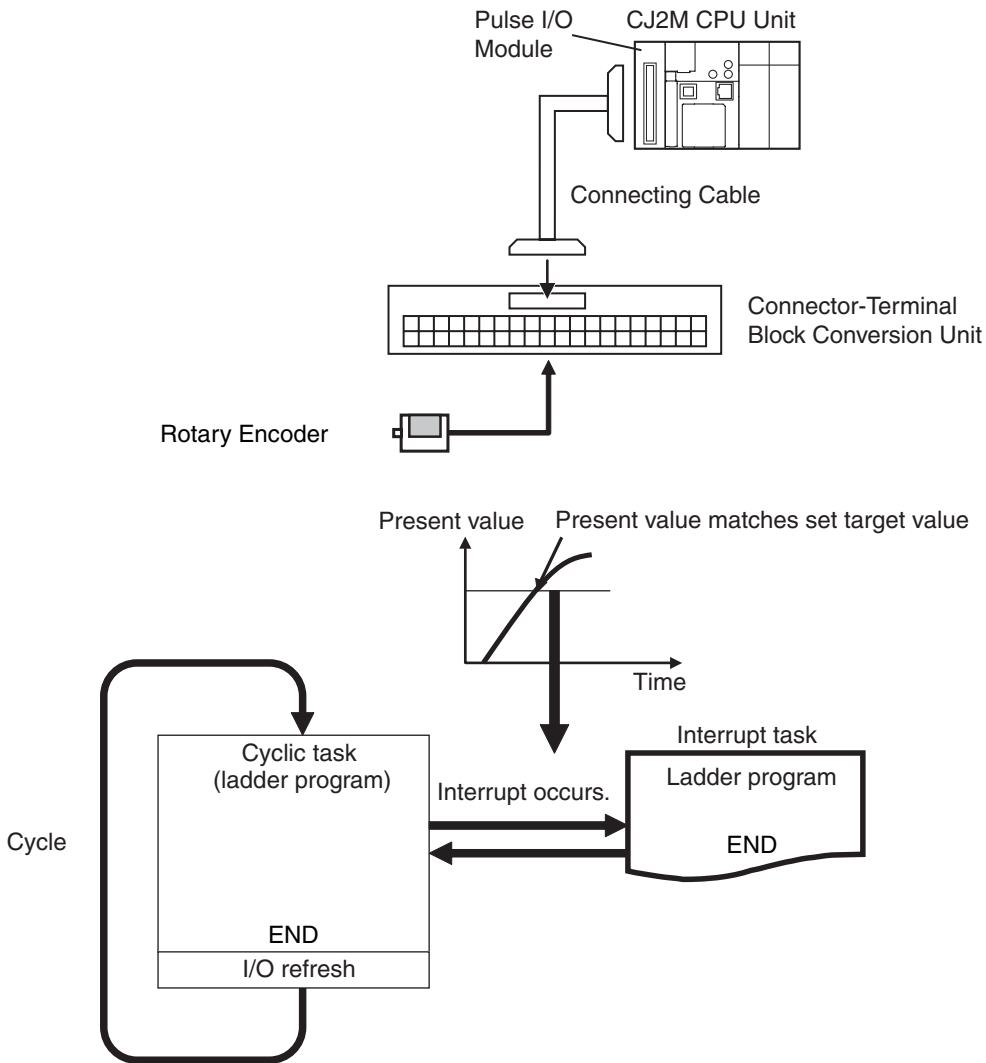

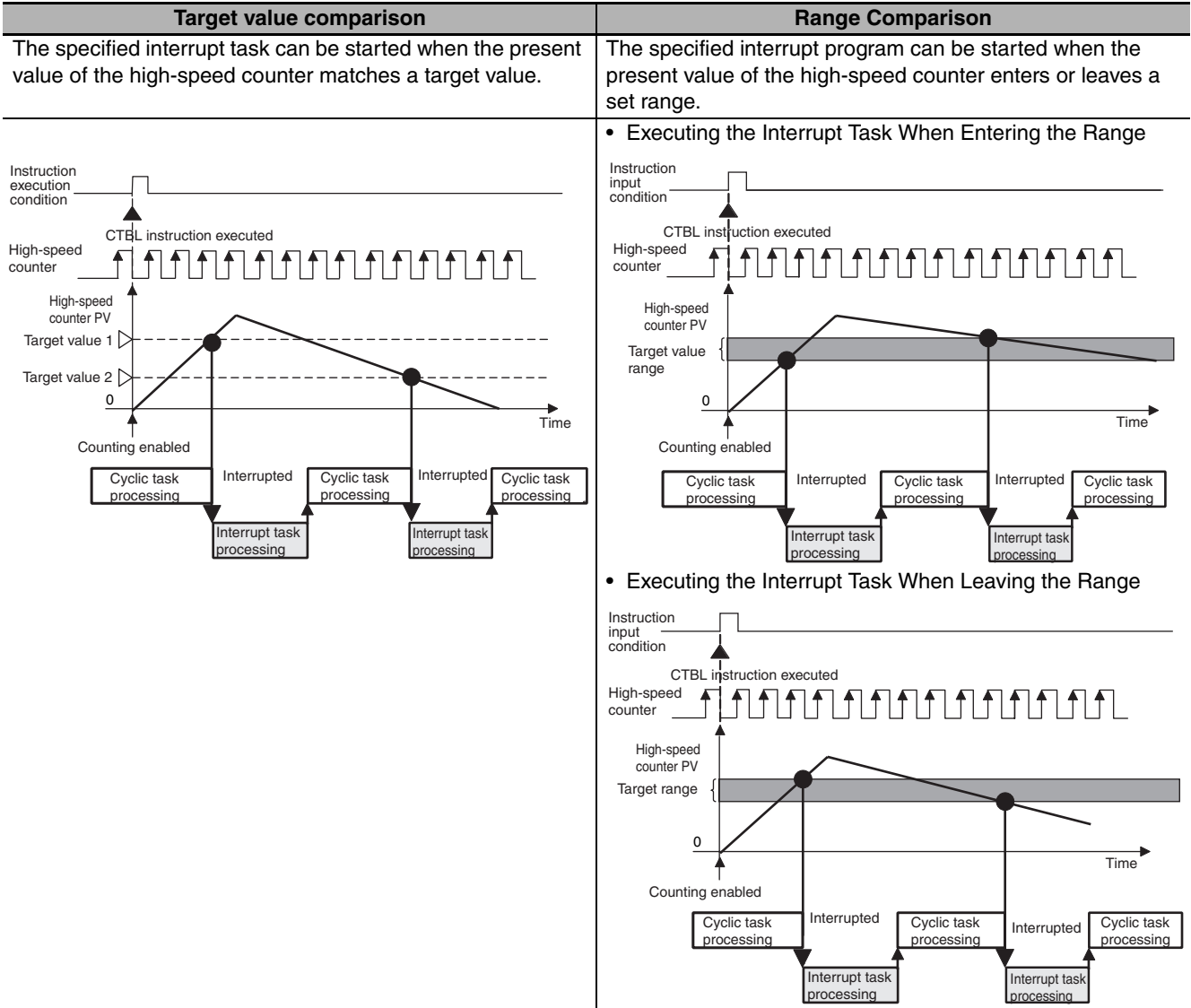

Application Procedure

1

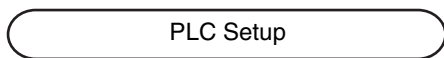

2

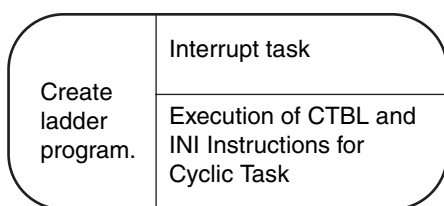

- Set the operation of the high-speed counters.
- Select the required input pulse frequency from the High-speed Counter Detailed Settings Dialog Box that is accessed from the I/O Module Tab Page of the PLC Setup using the CX-Programmer. Set the counting mode, reset method, pulse input mode, and other parameters.
- Input terminals IN02, IN03, IN06 to IN09, IN12, IN13, and IN16 to IN19 can be used for high-speed counters. These correspond to high-speed counters 0 to 3.
- Write a program for interrupt tasks 0 to 255.
- Set the comparison values for the high-speed counter and the interrupt tasks (0 to 255) to be started using the CTBL(882) instruction.
- Start the comparison using the INI(880) instruction. The comparison can be started simultaneously when registering the comparison values using the CTBL(882) instruction.

High-speed Counter Interrupts Settings

Pulse I/O Module No.	I/O Module Tab Page in PLC Setup	Instruction	CTBL port specifier (P)	Interrupt task number
0 (on the right)	High-speed counter 0	Select <i>Use</i> Check Box.	CTBL(882)	0 to 255 (Specified by user.)
	High-speed counter 1			
1 (on the left)	High-speed counter 2		#0002	
	High-speed counter 3		#0003	

PLC Setup

Click the **I/O Module** Tab and then click the **Set** Button in the High-speed Counter Settings Area. In the High-speed Counter Detailed Settings Dialog Box, select the input pulse frequency for the *Counter setting* parameter and set the counting mode, ring counter maximum value, reset method, pulse input method, and other parameters.

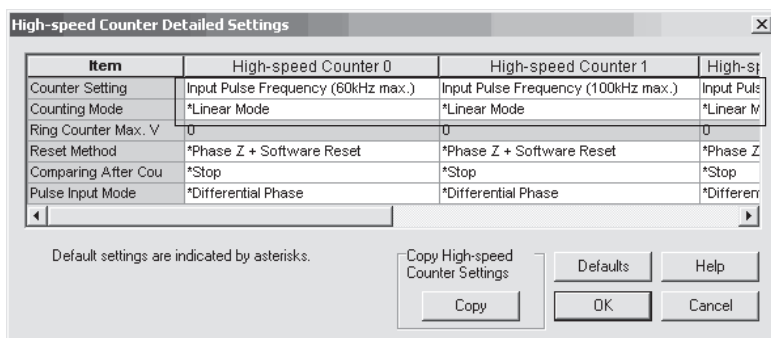

Refer to 7-1-2 Application Procedure for details.

Determining High-speed Counters

High-speed counters 0 to 3 can be used for high-speed counter interrupts.

- Refer to *2-2-3 Allocating Functions to Input Terminals* for information on allocating input terminals to high-speed counters.
- Refer to *Section 6 Interrupts* for information on interrupts except for the high-speed counter interrupts.

Creating Ladder Programs

● Writing the Interrupt Task Program

Create programs for interrupt tasks 0 to 255, which are executed for the corresponding high-speed counter interrupts. Right-click the program set as the interrupt task in the CX-Programmer and select **Properties**. Select any interrupt task in the Task type Field of the Program Properties Dialog Box.

● Executing CTBL(882) and INI(880) Instructions in Cyclic Task

Execute the instructions in the following order.

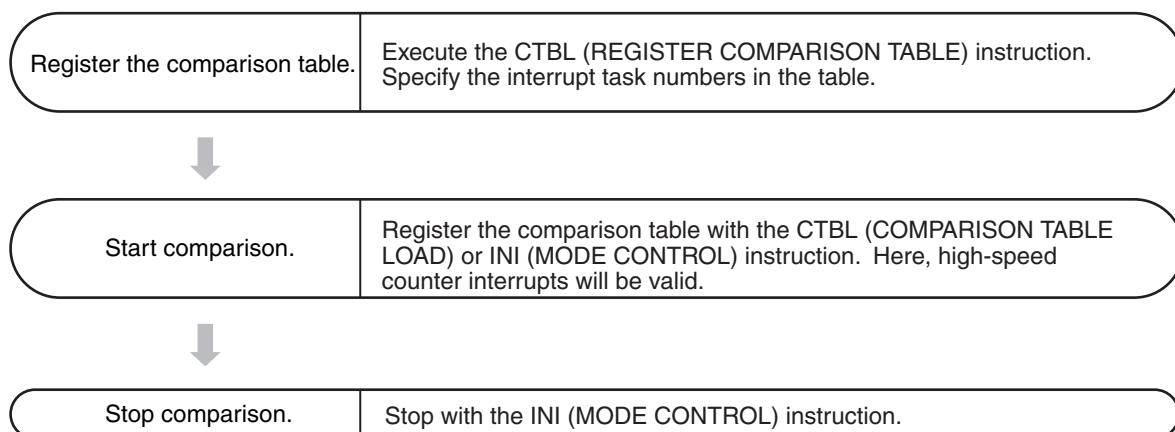

Refer to *7-3-2 Present Value Comparison* for details.

7-3-2 Present Value Comparison

There are two ways to compare the high-speed counter PV: Target Value Comparison and Range Comparison.

Target comparison and range comparison cannot be used for the same high-speed counter at the same time.

Target Value Comparison

The specified interrupt task is executed when the high-speed counter PV matches a target value registered in the table.

- The comparison conditions (target values and counting directions) are registered in the comparison table along with the corresponding interrupt task number. The specified interrupt task will be executed when the high-speed counter PV matches the registered target value.
- When using target values, comparisons are made for all of the target values in the comparison table regardless of the order of the target values in the table.

The following examples show the operation of an interrupt task for a comparison table.

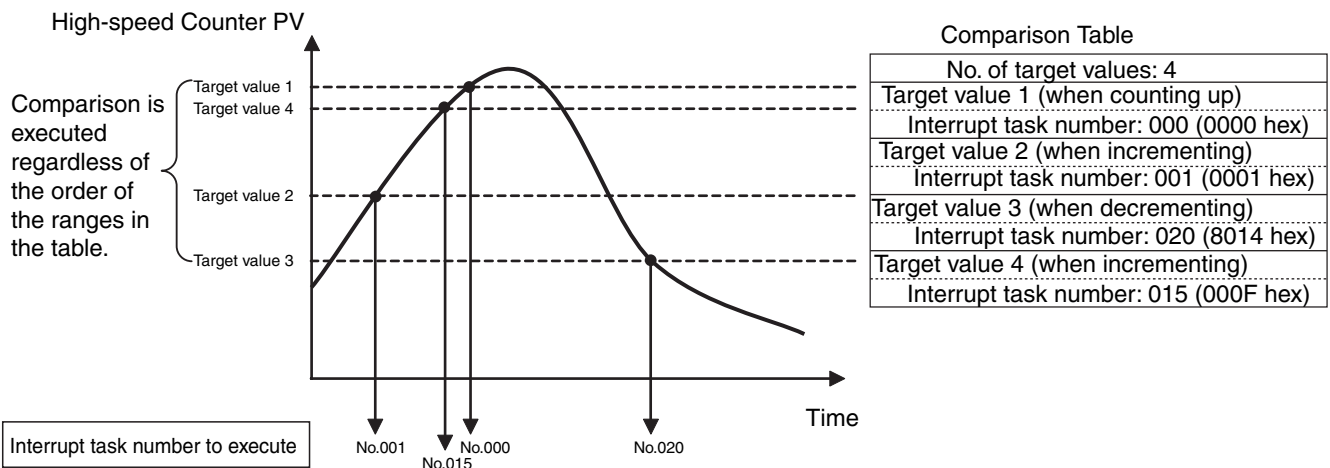

- Between 1 and 48 target values can be registered in the comparison table.
- A different interrupt task can be registered for each target value.
- If the PV is changed, the changed PV will be compared with the target values in the table, even if the PV is changed while the target value comparison operation is in progress.



Precautions for Correct Use

- When the count direction (incrementing/decrementing) changes at a PV that matches a target value, the next target value will not be matched in that direction.
Set the target values so that they do not occur at the peak or trough of count value changes.

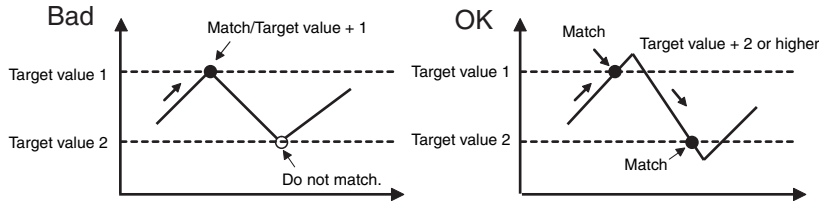

- The comparison conditions (target value and count directions) cannot be set more than once in the same table. An instruction error will occur if the same comparison conditions appear twice.
- An instruction error will occur if “when decrementing” is set as the comparison condition when the high-speed counter is set to Increment Pulse Input Mode.
- The maximum response frequencies of the high-speed counters are given in the following table.

Pulse I/O Module No.	Item	Maximum response frequency
0 (on the right)	High-speed counter 0 or 1	Increment pulse
		Up and down pulses
		Pulse + Direction Mode
		Differential phase (×4)
1 (on the left)	High-speed counter 2 or 3	Increment pulse
		Up and down pulses
		Pulse + direction
		Differential phase (×4)

Range Comparison

The specified interrupt task is executed when the high-speed counter PV enters or leaves the range defined by the upper and lower limit values.

- The comparison conditions (upper and lower limits and entering or leaving the range) are registered in the comparison table along with the corresponding interrupt task numbers. The specified interrupt task will be executed once when the high-speed counter PV enters or leaves the range.

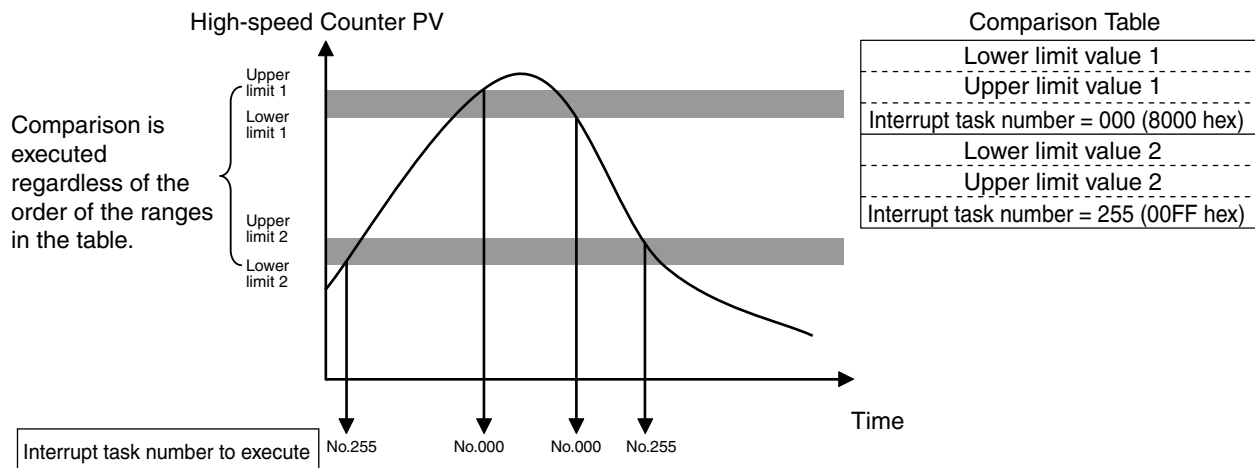

- There are two ways to register comparison tables for range comparison. You can register a fixed-length comparison table with eight ranges, or you can register a variable-length comparison table with 1 to 32 ranges. If you register a fixed-length table, the programming and data for CJ1M PLCs can be used without modifications. If you register a variable-length comparison table, you can register up to 32 ranges or you can register only the required number of ranges so that less memory is used.
- The ranges can overlap.
- A different interrupt task can be registered for each range.
- The leftmost bit (bit 15) of the word containing the interrupt task number specifies if the interrupt task is to be executed when the range is entered or left.
 - Bit 15 = OFF: The interrupt task will be executed when the range is entered.
 - Bit 15 = ON: The interrupt task will be executed when the range is left.
- The counter PV is compared with the 8 ranges or 1 to 32 ranges once each cycle.
- When the PV of the high-speed counter is changed, the applicable interrupt tasks will be executed if the new PV falls within any table ranges regardless of whether interrupt execution is specified when the PV enters or leaves the range.



Precautions for Correct Use

- When more than one comparison condition is met in a cycle, the first interrupt task in the table will be executed in that cycle. Even if more than one comparison condition is met when the PV enters or exits the range, the first interrupt task in the table will be executed. The next interrupt task in the table will be executed in the next cycle.
- Once an interrupt task has been executed from a table, the interrupt task will not be executed again for the same table until the PV enters or leaves that comparison range. However, regardless of whether interrupt execution is specified when the PV enters or leaves a particular range, the Range Comparison Condition In-range Flag will be ON when the PV is within the set range.
- Even if a table range is left because the PV is reset to zero (for either a software reset or phase Z + software reset), the applicable interrupt task will not be executed.



Additional Information

The range comparison table can be used without starting an interrupt task when the comparison condition is met. The range comparison function can be useful when you just want to know whether or not the high-speed counter PV is within a particular range.

Use the Range Comparison Condition In-range Flags (bits 00 to 07 in A274, A275, A320, and A312 or words A10128 to A10135) to determine whether the high-speed counter PV is within a registered range.

7-3-3 High-speed Counter Interrupt Instructions

REGISTER COMPARISON TABLE Instruction: CTBL(882)

The CTBL(882) instruction compares the PV of a high-speed counter (0 to 3) to target values or ranges and executes the corresponding interrupt task (0 to 255) when the specified condition is met.

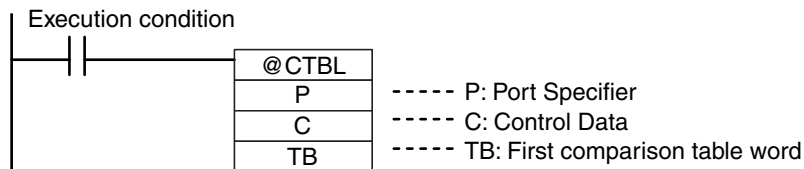

Operand		Setting	
P	Port specifier	#0000	High-speed counter 0
		#0001	High-speed counter 1
		#0002	High-speed counter 2
		#0003	High-speed counter 3
C	Control data	#0000	Registers a target value comparison table and starts comparison.
		#0001	Registers a fixed-length range comparison table (8 ranges) and starts the comparison operation.
		#0002	Registers a target-value comparison table.
		#0003	Registers a fixed-length range comparison table (8 ranges).
		#0004	Registers a variable-length comparison table (1 to 32 ranges) and starts comparison.
		#0005	Registers a variable-length comparison table (1 to 32 ranges).
TB	First comparison table word	Specifies the first word address of the comparison table, which is described below.	

● Contents of the Comparison Table

• Target-value Comparison Table

Depending on the number of target values in the table, the target-value comparison table requires a continuous block of 4 to 145 words.

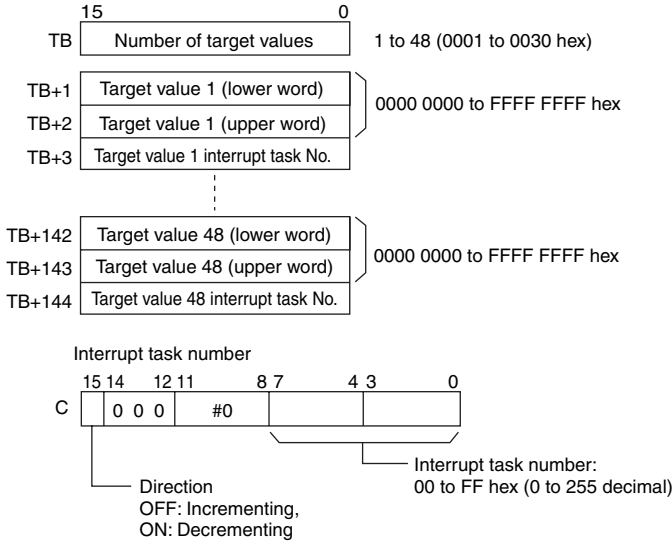

• Creating a Range Comparison Tables (Fixed Length of Eight Ranges)

The range comparison table requires a continuous block of 40 words for comparison conditions 1 to 8, which require 5 words each (two words for the upper range value, two words for the lower range value, and one word for the interrupt task number).

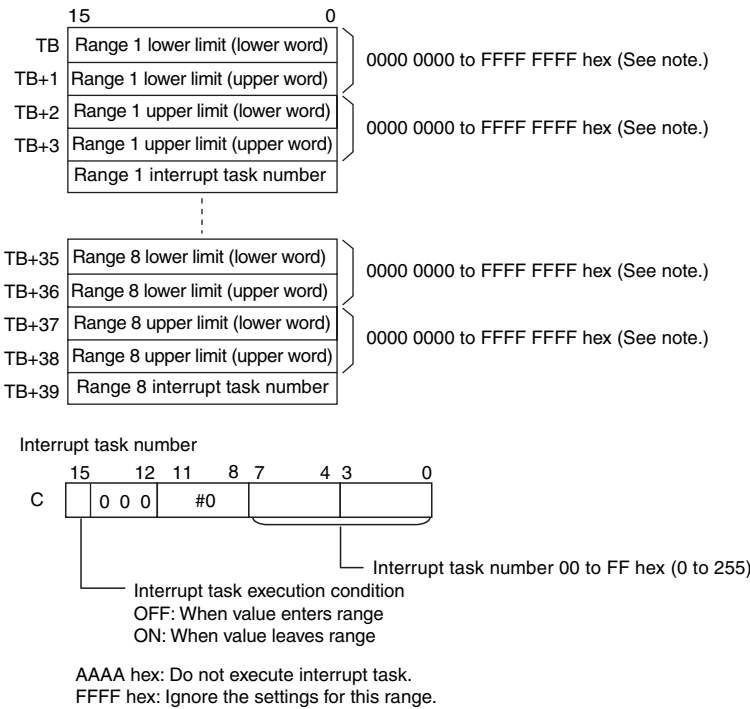

Note: Always set the upper limit greater than or equal to the lower limit for any one range.

- Creating a Range Comparison Tables (Variable Length of One to 32 Ranges)
 The number of ranges is registered along with the lower limit (2 words), upper limit (2 words), and interrupt task number (1 words) for each range from range 1 to 32.
 The comparison table can be between 6 and 161 words long, depending on the number of comparison ranges.

Set the ranges using upper and lower limits.

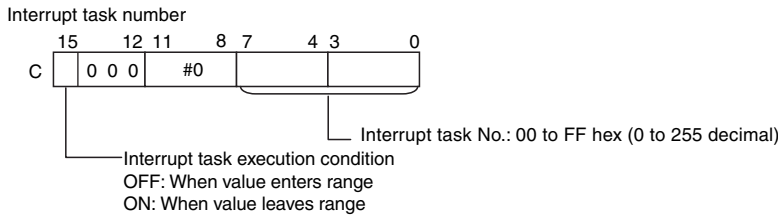
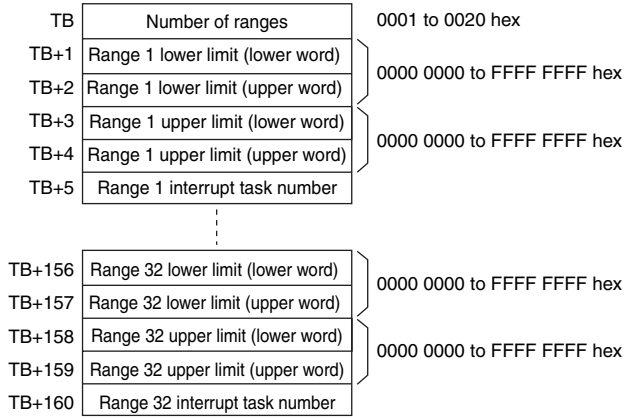

AAAA hex: Do not execute interrupt task.
 FFFF hex: Ignore the settings for this range.

MODE CONTROL Instruction: INI(880)

The INI(880) instruction is used for the following items.

- Starting and Stopping Comparison for a High-speed Counter Comparison Table
Use the CTBL(882) instruction to register the target value or range comparison table before using INI(880) to start or stop comparison.
If the comparison is started simultaneously with registering the comparison table and the high-speed counter interrupts are always enabled, the INI(880) instruction is not required.
- Changing the PV of a High-speed Counter

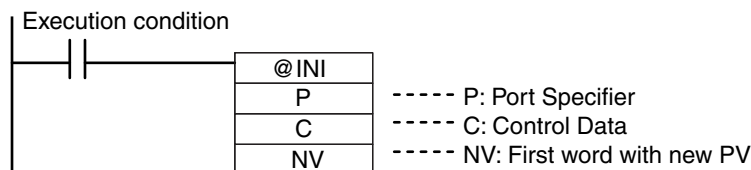

Operand		Setting	
P	Port specifier	#0010	High-speed counter 0
		#0011	High-speed counter 1
		#0012	High-speed counter 2
		#0013	High-speed counter 3
C	Control data	#0000	Starts comparison.
		#0001	Stops comparison.
		#0002	Changes the PV.
		#0006	Changes the maximum ring count.
NV	First word of new PV	Stores the new value when changing the PV (C = #0002) or when changing the ring counter maximum value (C = #0006)	

Example 1: Target Value Comparison

In this example, high-speed counter 0 operates in linear mode and starts interrupt task 10 when the PV reaches 30,000 (0000 7530 hex) and starts interrupt task 11 when the PV reaches 20,000 (0000 4E20 hex).

- Set high-speed counter 0 on the I/O Module Tab Page in the PLC Setup.

Item	Setting
Counter setting	Input pulse frequency (60 kHz max.)
Counting Mode	Linear mode
Ring Counter Max. Value	---
Reset Method	Software reset
Comparing After Counter Reset	Stop
Pulse Input Mode	Up/Down pulses

2 Set the target-value comparison table in words D1000 to D1006.

Word	Setting	Description	
D1000	#0002	Number of target values = 2	
D1001	#7530	Rightmost 4 digits of the target value 1 data (30,000)	Target value = 30,000
D1002	#0000	Leftmost 4 digits of the target value 1 data (30,000)	
D1003	#000A	Target value 1 Bit 15: 0 (incrementing) Bits 00 to 07: A hex (interrupt task number 10)	
D1004	#4E20	Rightmost 4 digits of the target value 2 data (20,000)	Target value = 20,000
D1005	#0000	Leftmost 4 digits of the target value 2 data (20,000)	
D1006	#800B	Target value 2 Bit 15: 1 (decrementing) Bits 00 to 07: B hex (interrupt task number 11)	

3 Create the programs for interrupt tasks 10 and 11.

4 Use the CTBL(882) instruction to start the comparison operation with high-speed counter 0 and interrupt tasks 10 and 11.

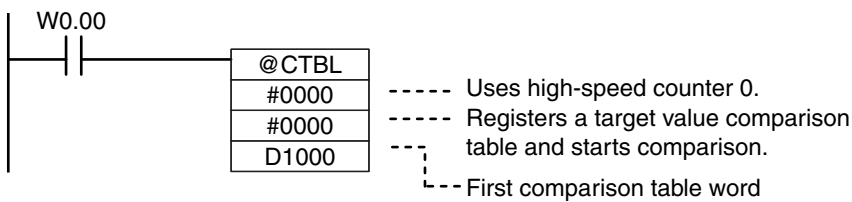

When execution condition W0.00 turns ON, the comparison starts for high-speed counter 0. When the PV of high speed counter 0 is incremented to 30,000, cyclic task execution is interrupted, and interrupt task 10 is executed.

When the PV of high speed counter 0 is decremented to 20,000, cyclic task execution is interrupted, and interrupt task 11 is executed.

When interrupt task 10 or 11 execution has been completed, execution of the interrupted cyclic task resumes.

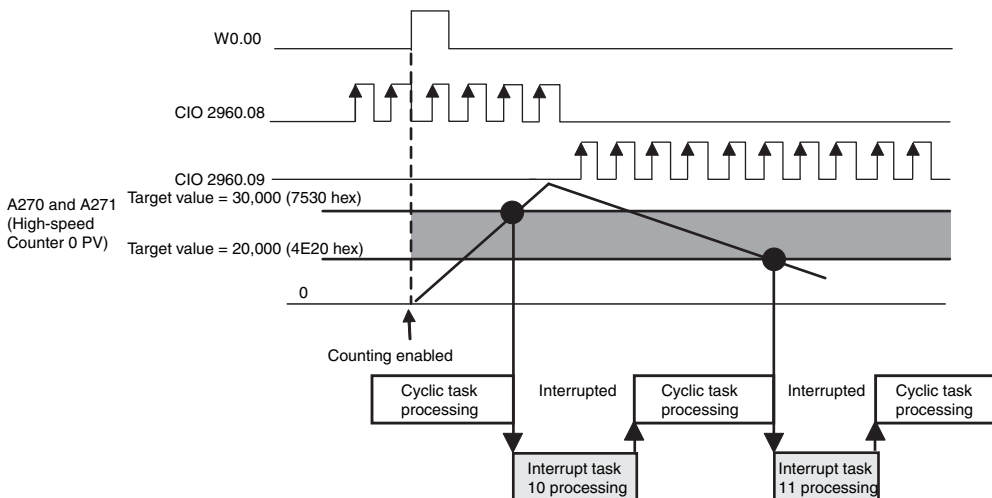

Example 2: Range Comparison

In this example, high-speed counter 1 operates in Ring Mode and starts interrupt task 12 when the PV enters the range from 25,000 (0000 61A8 hex) to 25,500 (0000 639C hex).

The ring counter maximum value is set to 50,000 (0000 C350 hex).

- 1 Set high-speed counter 1 on the I/O Module Tab Page in the PLC Setup.

Item	Setting
Counter setting	Input pulse frequency (100 kHz max.)
Counting Mode	Ring mode
Ring Counter Max. Value	50,000
Reset Method	Software reset
Comparing After Counter Reset	Continue
Pulse Input Mode	Up/Down pulses

- 2 Set the range comparison table starting at word D2000. Even though range 1 is the only range being used, all 40 words must still be dedicated to the range comparison table.

Word	Setting	Description	
D2000	#61A8	Rightmost 4 digits of range 1 lower limit	Lower limit value: 25,000
D2001	#0000	Leftmost 4 digits of range 1 lower limit	
D2002	#639C	Rightmost 4 digits of range 1 upper limit	Upper limit value: 25,500
D2003	#0000	Leftmost 4 digits of range 1 upper limit	
D2004	#000C	Range 1, Interrupt task 12 (C hex), when entering range (leftmost bit = ON)	
D2005 to D2008	All 0000	Range 2 lower and upper limit values (Not used and do not need to be set.)	
D2009	#FFFF	Disables range 2.	
?			
D2014 D2019 D2024 D2029 D2034 D2039	#FFFF	Set the 5th word for ranges 3 to 8 (listed at left) to FFFF hex (range settings are invalid) to disable those ranges.	

- 3 Create the program for interrupt task 12.
- 4 Use the CTBL(882) instruction to start the comparison operation with high-speed counter 1 and interrupt task 12.

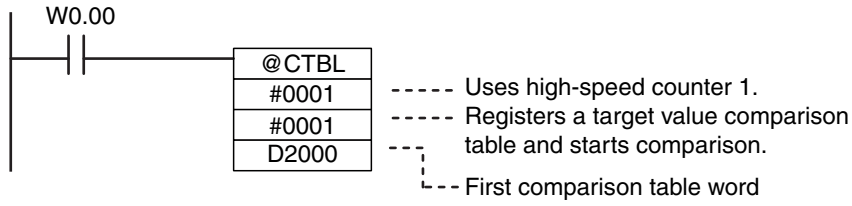

When execution condition W0.00 turns ON, the comparison starts for high-speed counter 1.

When the PV of high speed counter 1 is between 25,000 and 25,500, cyclic task execution is interrupted, and interrupt task 12 is executed.

When interrupt task 12 execution is completed, execution of the interrupted cyclic task resumes.

Example: Executing the Interrupt Task When Entering a Range

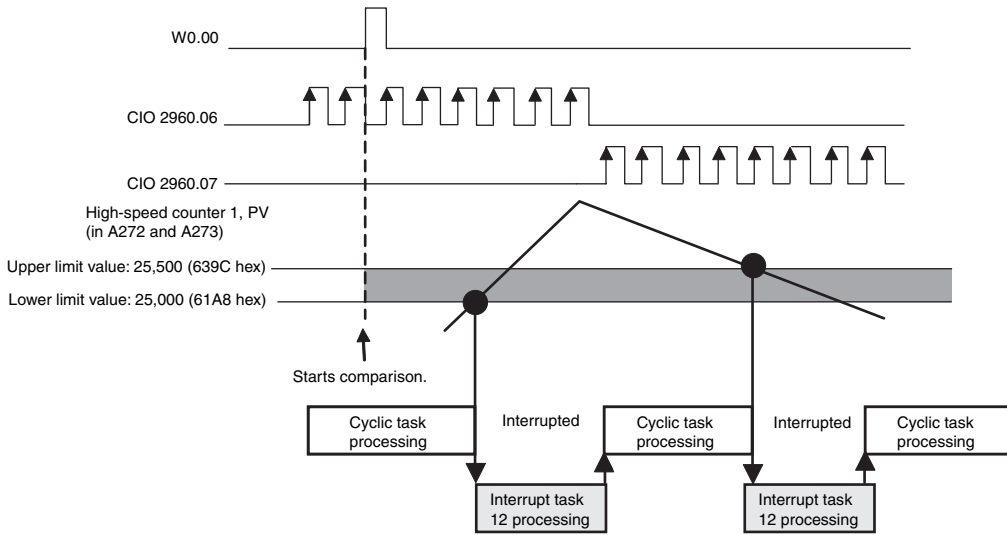

7-4 Related Auxiliary Area Words and Bits

Related Auxiliary Area Words and Bits

Name	Word/Bit	Function	Read/Write	Refresh timing
High-speed counter 0 PV	A270 to A271	Contain the PVs of high-speed counters 0 to 3. Lower four digits: A270, A272, A316, and A318 Upper four digits: A271, A273, A317, and A319	Read	<ul style="list-style-type: none"> • Cleared when power is turned ON. • Cleared when operation starts. • Refreshed each cycle during overseeing process. • Refreshed when PRV(881) instruction is executed to read the PV or status. • Refreshed when PRV2(883) instruction is executed to convert high-speed counter PV to total number of pulses. • Refreshed when INI(880) instruction is executed to change PV or ring counter maximum value.
High-speed counter 1 PV	A272 to A273			
High-speed counter 2 PV	A316 to A317			
High-speed counter 3 PV	A318 to A319			

Name	Word/Bit	Function	Read/Write	Refresh timing
High-speed Counter 0 Range Comparison Condition 1 In-range Flag	A274.00	These flags indicate whether the PV is within any of the eight ranges when high-speed counter 0 is being operated in range-comparison mode with upper and lower limits. The In-range Flags, however, will be ON whenever the comparison value is within the range regardless of whether the high-speed counter is set to execute the interrupt task when the range is entered or left. OFF: Not in range ON: In range	Read	<ul style="list-style-type: none"> • Cleared when power is turned ON. • Cleared when operation starts. • Refreshed each cycle during overseeing process. • Refreshed when PRV(881) instruction is executed to read the results of range comparison. • Refreshed when INI(880) instruction is executed to change PV or ring counter maximum value. • Refreshed when the counter is reset.
High-speed Counter 0 Range Comparison Condition 2 In-range Flag	A274.01			
High-speed Counter 0 Range Comparison Condition 3 In-range Flag	A274.02			
High-speed Counter 0 Range Comparison Condition 4 In-range Flag	A274.03			
High-speed Counter 0 Range Comparison Condition 5 In-range Flag	A274.04			
High-speed Counter 0 Range Comparison Condition 6 In-range Flag	A274.05			
High-speed Counter 0 Range Comparison Condition 7 In-range Flag	A274.06			
High-speed Counter 0 Range Comparison Condition 8 In-range Flag	A274.07			
High-speed Counter 0 Comparison In-progress Flag	A274.08	This flag indicates whether a comparison operation is being executed for high-speed counter 0. OFF: Stopped. ON: Being executed.	Read	<ul style="list-style-type: none"> • Cleared when power is turned ON. • Cleared when starting operation. • Refreshed when starting/stopping comparison.
High-speed Counter 0 Overflow/Underflow Flag	A274.09	This flag indicates when an overflow or underflow has occurred in the high-speed counter 0 PV. (Used only when the counting mode is set to Linear Mode.) OFF: Normal ON: Overflow or underflow	Read	<ul style="list-style-type: none"> • Cleared when power is turned ON. • Cleared when operation starts. • Cleared when the PV is changed. • Refreshed when an overflow or underflow occurs.

Name	Word/Bit	Function	Read/Write	Refresh timing
High-speed Counter 0 Count Direction	A274.10	This flag indicates whether the high-speed counter is currently being incremented or decremented. The counter PV for the current cycle is compared with the PV in last cycle to determine the result. OFF: Decrementing ON: Incrementing	Read	<ul style="list-style-type: none"> Setting used for high-speed counter, valid during counter operation. Refreshed each cycle during overseeing process. Refreshed when PRV(881) instruction is executed to read the PV or status.
High-speed Counter 1 Range Comparison Condition 1 In-range Flag	A275.00	These flags indicate whether the PV is within any of the eight ranges when high-speed counter 1 is being operated in range-comparison mode with upper and lower limits. The In-range Flags, however, will be ON whenever the comparison value is within the range regardless of the whether the high-speed counter is set to execute the interrupt task when the range is entered or left. OFF: Not in range ON: In range	Read	<ul style="list-style-type: none"> Cleared when power is turned ON. Cleared when operation starts. Refreshed each cycle during overseeing process. Refreshed when PRV(881) instruction is executed for the corresponding counter. Refreshed when INI(880) instruction is executed to change PV or ring counter maximum value. Reset
High-speed Counter 1 Range Comparison Condition 2 In-range Flag	A275.01			
High-speed Counter 1 Range Comparison Condition 3 In-range Flag	A275.02			
High-speed Counter 1 Range Comparison Condition 4 In-range Flag	A275.03			
High-speed Counter 1 Range Comparison Condition 5 In-range Flag	A275.04			
High-speed Counter 1 Range Comparison Condition 6 In-range Flag	A275.05			
High-speed Counter 1 Range Comparison Condition 7 In-range Flag	A275.06			
High-speed Counter 1 Range Comparison Condition 8 In-range Flag	A275.07			
High-speed Counter 1 Comparison In-progress Flag	A275.08	This flag indicates whether a comparison operation is being executed for high-speed counter 1. OFF: Stopped ON: Being executed	Read	<ul style="list-style-type: none"> Cleared when power is turned ON. Cleared when starting operation. Refreshed when starting/stopping comparison.

Name	Word/Bit	Function	Read/Write	Refresh timing
High-speed Counter 1 Overflow/Underflow Flag	A275.09	This flag indicates when an overflow or underflow has occurred in the high-speed counter 1 PV. (Used only when the counting mode is set to Linear Mode.) OFF: Normal ON: Overflow or underflow	Read	<ul style="list-style-type: none"> Cleared when power is turned ON. Cleared when operation starts. Cleared when the PV is changed. Refreshed when an overflow or underflow occurs.
High-speed Counter 1 Count Direction	A275.10	This flag indicates whether high-speed counter 1 is currently being incremented or decremented. The counter PV for the current cycle is compared with the PV in last cycle to determine the result. OFF: Decrementing ON: Incrementing	Read	<ul style="list-style-type: none"> Setting used for high-speed counter, valid during counter operation. Refreshed each cycle during overseeing process. Refreshed when PRV(881) instruction is executed to read the PV or status.
High-speed Counter 2 Range Comparison Condition 1 In-range Flag	A320.00	<p>These flags indicate whether the PV is within any of the eight ranges when high-speed counter 2 is being operated in range-comparison mode with upper and lower limits.</p> <p>The In-range Flags, however, will be ON whenever the comparison value is within the range regardless of the whether the high-speed counter is set to execute the interrupt task when the range is entered or left.</p> <p>OFF: Not in range ON: In range</p>	Read	<ul style="list-style-type: none"> Cleared when power is turned ON. Cleared when operation starts. Refreshed each cycle during overseeing process. Refreshed when PRV(881) instruction is executed for the corresponding counter. Refreshed when INI(880) instruction is executed to change PV or ring counter maximum value. Reset
High-speed Counter 2 Range Comparison Condition 2 In-range Flag	A320.01			
High-speed Counter 2 Range Comparison Condition 3 In-range Flag	A320.02			
High-speed Counter 2 Range Comparison Condition 4 In-range Flag	A320.03			
High-speed Counter 2 Range Comparison Condition 5 In-range Flag	A320.04			
High-speed Counter 2 Range Comparison Condition 6 In-range Flag	A320.05			
High-speed Counter 2 Range Comparison Condition 7 In-range Flag	A320.06			
High-speed Counter 2 Range Comparison Condition 8 In-range Flag	A320.07			

Name	Word/Bit	Function	Read/Write	Refresh timing
High-speed Counter 2 Comparison In-progress Flag	A320.08	This flag indicates whether a comparison operation is being executed for high-speed counter 2. OFF: Stopped. ON: Being executed.	Read	<ul style="list-style-type: none"> • Cleared when power is turned ON. • Cleared when starting operation. • Refreshed when starting/stopping comparison.
High-speed Counter 2 Overflow/Underflow Flag	A320.09	This flag indicates when an overflow or underflow has occurred in the high-speed counter 2 PV. (Used only when the counting mode is set to Linear Mode.) OFF: Normal ON: Overflow or underflow	Read	<ul style="list-style-type: none"> • Cleared when power is turned ON. • Cleared when operation starts. • Cleared when the PV is changed. • Refreshed when an overflow or underflow occurs.
High-speed Counter 2 Count Direction	A320.10	This flag indicates whether high-speed counter 2 is currently being incremented or decremented. The counter PV for the current cycle is compared with the PV in last cycle to determine the result. OFF: Decrementing ON: Incrementing	Read	<ul style="list-style-type: none"> • Setting used for high-speed counter, valid during counter operation. • Refreshed each cycle during overseeing process. • Refreshed when PRV(881) instruction is executed to read the PV or status.

Name	Word/Bit	Function	Read/Write	Refresh timing
High-speed Counter 3 Range Comparison Condition 1 In-range Flag	A321.00	These flags indicate whether the PV is within any of the eight ranges when high-speed counter 3 is being operated in range-comparison mode with upper and lower limits. The In-range Flags, however, will be ON whenever the comparison value is within the range regardless of whether the high-speed counter is set to execute the interrupt task when the range is entered or left. OFF: Not in range ON: In range	Read	<ul style="list-style-type: none"> • Cleared when power is turned ON. • Cleared when operation starts. • Refreshed each cycle during overseeing process. • Refreshed when PRV(881) instruction is executed for the corresponding counter. • Refreshed when INI(880) instruction is executed to change PV or ring counter maximum value. • Reset
High-speed Counter 3 Range Comparison Condition 2 In-range Flag	A321.01			
High-speed Counter 3 Range Comparison Condition 3 In-range Flag	A321.02			
High-speed Counter 3 Range Comparison Condition 4 In-range Flag	A321.03			
High-speed Counter 3 Range Comparison Condition 5 In-range Flag	A321.04			
High-speed Counter 3 Range Comparison Condition 6 In-range Flag	A321.05			
High-speed Counter 3 Range Comparison Condition 7 In-range Flag	A321.06			
High-speed Counter 3 Range Comparison Condition 8 In-range Flag	A321.07			
High-speed Counter 3 Comparison In-progress Flag	A321.08	This flag indicates whether a comparison operation is being executed for high-speed counter 3. OFF: Stopped. ON: Being executed.	Read	<ul style="list-style-type: none"> • Cleared when power is turned ON. • Cleared when starting operation. • Refreshed when starting/stopping comparison.
High-speed Counter 3 Overflow/Underflow Flag	A321.09	This flag indicates when an overflow or underflow has occurred in the high-speed counter 3 PV. (Used only when the counting mode is set to Linear Mode.) OFF: Normal ON: Overflow or underflow	Read	<ul style="list-style-type: none"> • Cleared when power is turned ON. • Cleared when operation starts. • Cleared when the PV is changed. • Refreshed when an overflow or underflow occurs.

Name	Word/Bit	Function	Read/Write	Refresh timing
High-speed Counter 3 Count Direction	A321.10	This flag indicates whether high-speed counter 3 is currently being incremented or decremented. The counter PV for the current cycle is compared with the PV in last cycle to determine the result. OFF: Decrementing ON: Incrementing	Read	<ul style="list-style-type: none"> Setting used for high-speed counter, valid during counter operation.
High-speed Counter 0 Range Comparison Condition 1 to 32 In-range Flags	A10128 and A10129	<p>These flags indicate whether the PV is within any of the 1 to 32 ranges when a high-speed counter (0 to 3) is being operated in range-comparison mode with upper and lower limits.</p> <p>The In-range Flags, however, will be ON whenever the comparison value is within the range regardless of the whether the high-speed counter is set to execute the interrupt task when the range is entered or left.</p> <p>OFF: Not in range ON: In range</p> <p>Bits 00 to 15 in the lower word correspond to ranges 1 to 16. Bits 00 to 15 in the upper word correspond to ranges 17 to 32.</p>	Read	<ul style="list-style-type: none"> Cleared when power is turned ON. Cleared when operation is started. Refreshed each cycle (overseeing processing). Refreshed when comparison is executed for 1 to 32 ranges. Refreshed when PRV(881) instruction is executed to read the results of range comparison. Refreshed when INI(880) instruction is executed to change PV or ring counter maximum value. Reset
High-speed Counter 1 Range Comparison Condition 1 to 32 In-range Flags	A10130 and A10131			
High-speed Counter 2 Range Comparison Condition 1 to 32 In-range Flags	A10132 and A10133			
High-speed Counter 3 Range Comparison Condition 1 to 32 In-range Flags	A10134 and A10135			
High-speed Counter 0 Ring Counter Maximum Value	A10136 and A10137	<p>Contain the ring counter maximum values when high-speed counters 0 to 3 are used as ring counters.</p> <p>These values are cleared to 0 if Linear Mode is used.</p> <p>Lower four digits: A10136, A10138, A10140, and A10142</p> <p>Upper four digits: A10137, A10139, A10141, and A10143</p>	Read	<ul style="list-style-type: none"> Cleared when power is turned ON. Cleared when operation starts. Refreshed when INI(880) instruction is executed to change ring counter maximum value.
High-speed Counter 1 Ring Counter Maximum Value	A10138 and A10139			
High-speed Counter 2 Ring Counter Maximum Value	A10140 and A10141			
High-speed Counter 3 Ring Counter Maximum Value	A10142 and A10143			
High-speed Counter 0 Reset Bit	A531.00	<p>When the reset method is set to a phase-Z signal + software reset, the corresponding high-speed counter's PV will be reset if the phase-Z signal is received while this flag is ON.</p> <p>When the reset method is set to a software reset, the corresponding high-speed counter's PV will be reset in the cycle when this bit turns ON.</p>	Read/Write	<ul style="list-style-type: none"> Cleared when power is turned ON.
High-speed Counter 1 Reset Bit	A531.01			
High-speed Counter 2 Reset Bit	A531.02			
High-speed Counter 3 Reset Bit	A531.03			

Name	Word/Bit	Function	Read/Write	Refresh timing
High-speed Counter 0 Gate Bit	A531.08	<p>If one of these flags is turned ON, the high-speed counter will not count even if pulse inputs are received and the counter PV will be maintained at its current value.</p> <p>When the flag is turned OFF, the high-speed counter will resume counting and the counter PV will be refreshed.</p> <p>This flag will be disabled if the high-speed counter's reset method is set to Phase-Z signal + Software reset and the Reset Bit (A531.00 to A531.03) is ON.</p>	Read/Write	<ul style="list-style-type: none"> • Cleared when power is turned ON.
High-speed Counter 1 Gate Bit	A531.09			
High-speed Counter 2 Gate Bit	A531.10			
High-speed Counter 3 Gate Bit	A531.11			

7-5 Application Examples

Using a Rotary Encoder to Measure Positions

● Functions Used: High-speed Counting

A high-speed counter input can be used by connecting a rotary encoder to an input terminal. A Pulse I/O Module is equipped with more than one high-speed counter input, making it possible to control devices for multiple axes with a single PLC.

High-speed counters can be used for high-speed processing, using either target value comparison or range comparison to create interrupts. Interrupt tasks are executed when the counter value reaches a specific target value or range.

● Operation

A sheet feeder is controlled to feed constant lengths in a given direction, e.g., for vacuum packing of food products.

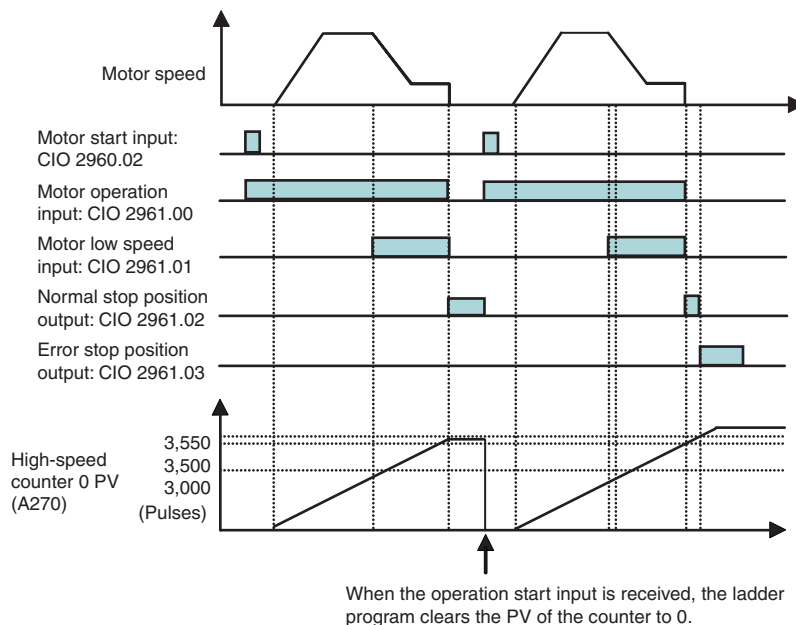

While the pulse count is between 3,500 and 3,550, the normal stop position output (CIO 2961.02) will be ON. If the pulse count exceeds 3,550, the error stop position output (CIO 2961.03) will turn ON.

● System configuration
Wiring Example

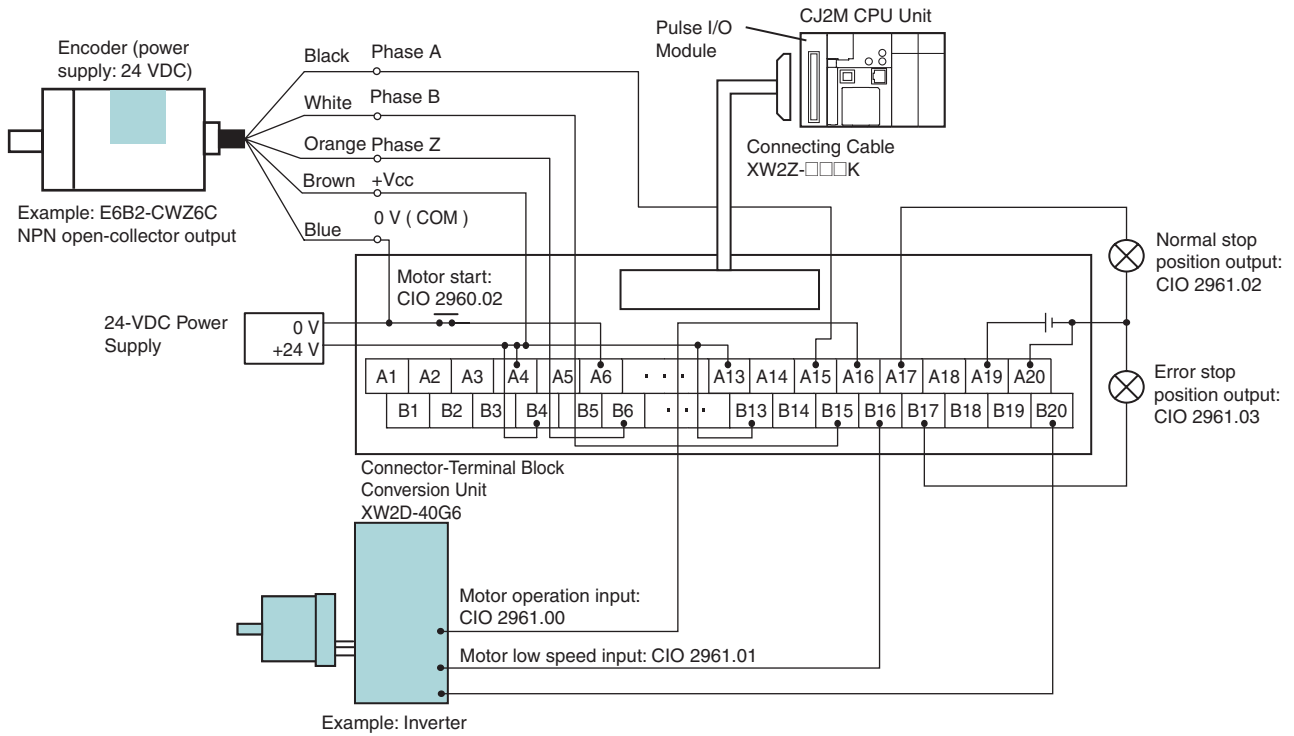

PLC Setup

Use the following procedure to enable high-speed counter 0.

- 1 Click the **Set** Button in the High-speed Counters Area.
The High-speed Counter Detailed Settings Dialog Box will be displayed.

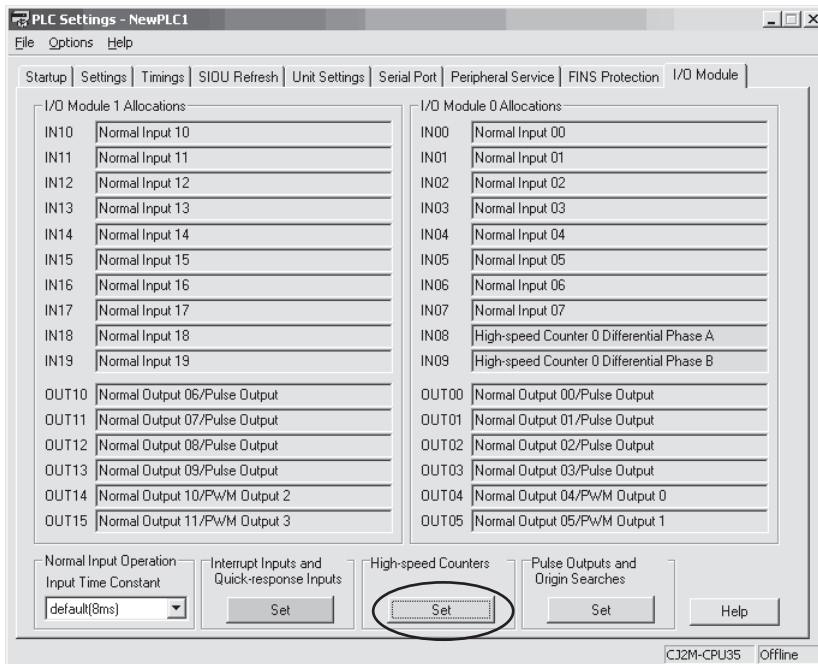

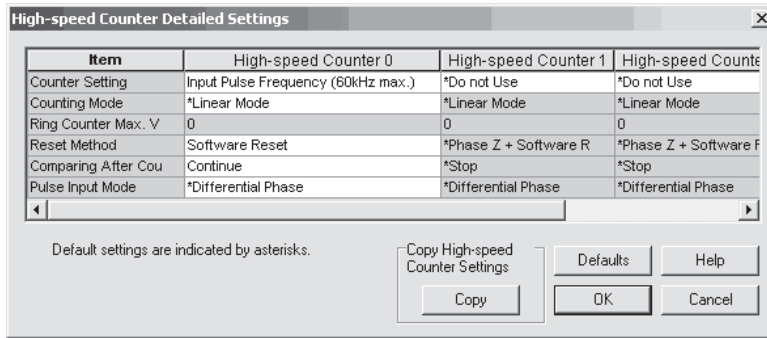

- 2** Select an input frequency of 100 kHz max. for the counter setting for high-speed counter 0.
- 3** Select *Linear mode* for the counting mode.
- 4** Select *Software Reset* for the reset method.
- 5** Select *Continue* for the comparison operation after resetting.
- 6** Select *Differential Phase* for the pulse input mode.
- 7** Transfer the PLC Setup to the CJ2M CPU Unit.
- 8** Close the PLC Settings Dialog Box.
- 9** Turn the power supply to the PLC OFF and then back ON.
The changes made to the PLC Setup will be applied.

● Ladder Program

The CTBL(882) instruction is used to execute interrupt tasks when the target positions are reached.

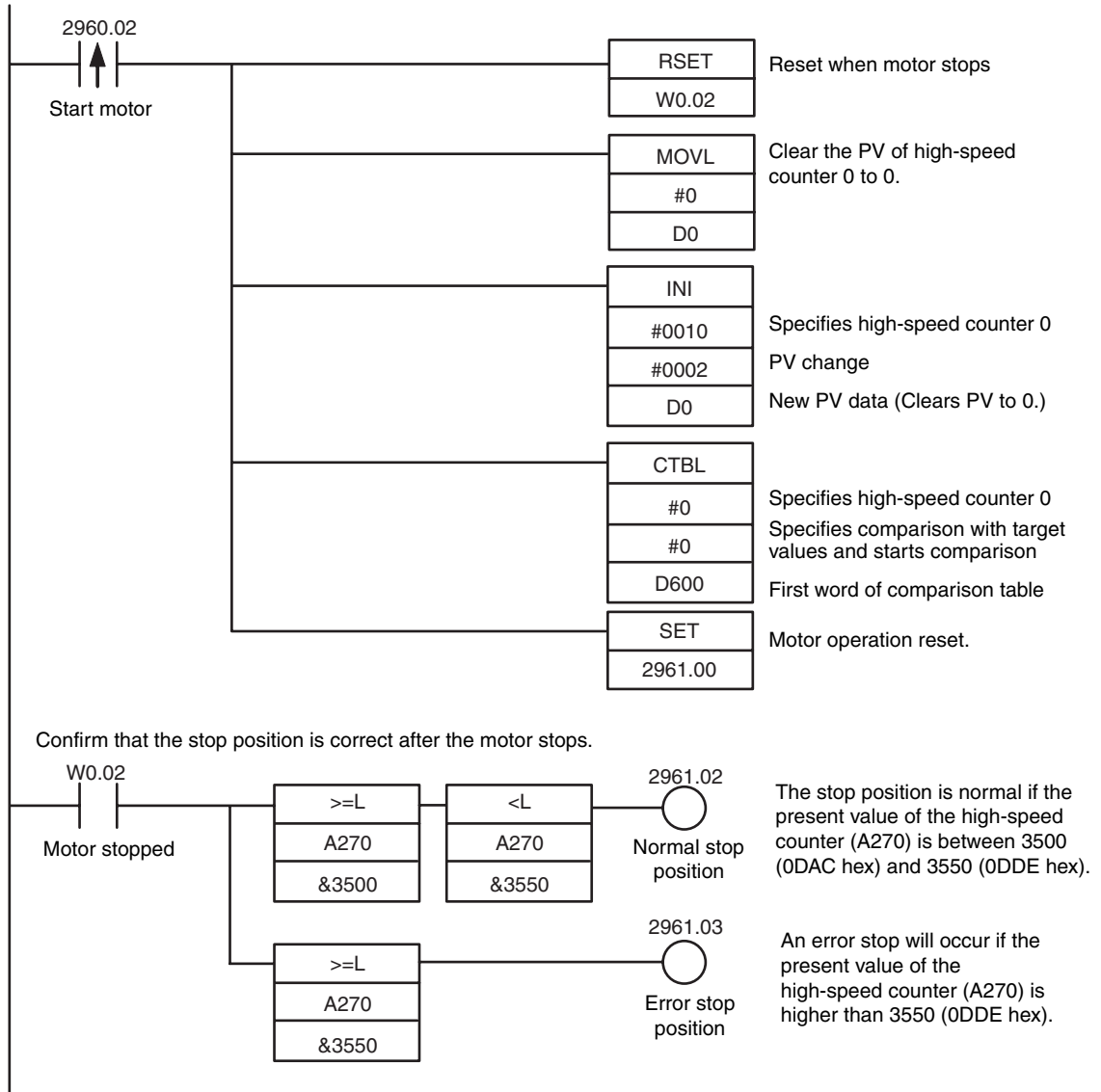

When the present value of the high-speed counter matches target value 1 (3,000), interrupt task 143 is executed.

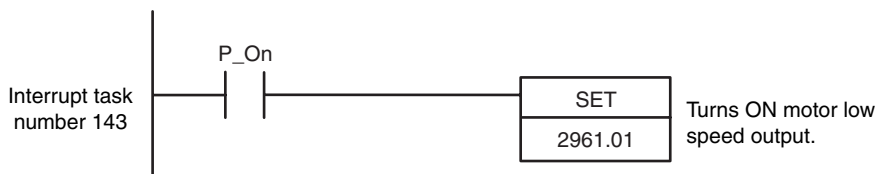

When the present value of the high-speed counter matches target value 2 (3,500), interrupt task 144 is executed.

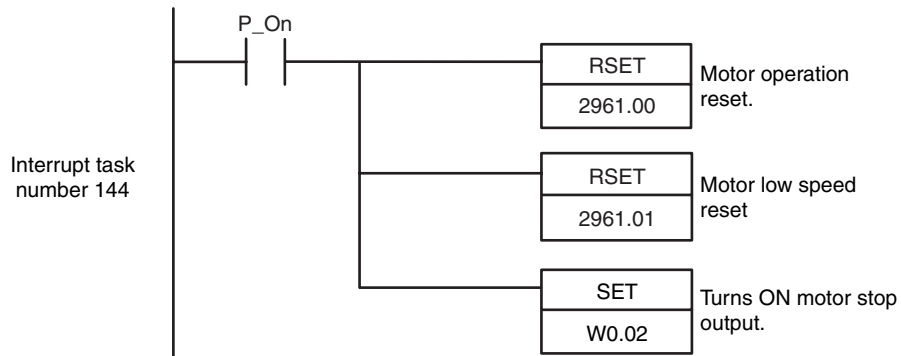

DM Area Settings

The comparison table for the CTBL(882) (REGISTER COMPARISON TABLE) instruction is set in D600 through D606.

Word	Value	Description
D600	0002	Number of target values: 2
D601	0BB8	Target value 1: 3,000 (BB8 hex)
D602	0000	
D603	008F	Target value 1: Interrupt task No.143
D604	0DAC	Target value 2: 3,500 (0DAC hex)
D605	0000	
D606	0090	Target value 2: Interrupt task No. 144

Length Measurement (Using Interrupts to Read Input Pulses)

● Specifications and Operation

The number of encoder pulse inputs is counted with high-speed counter input 1. Sensor inputs 1 and 2 are read as interrupt inputs at terminals IN00 (CIO 2960.00) and IN01 (CIO 2960.01). The workpiece length is measured by the number of pulses counted between an ON input at sensor input 1 and an ON input at sensor input 2.

The program finds the difference between the high-speed counter PVs that are latched for interrupt inputs IN00 and IN01 and outputs the difference to D10.

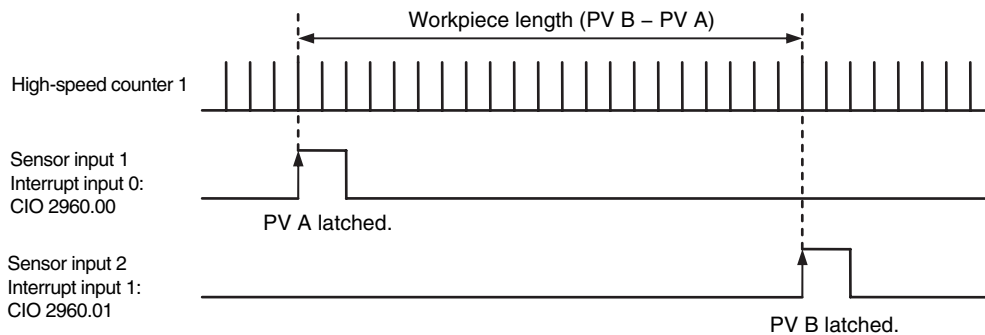

● Applicable Instructions

MSKS(690) instruction: Enables I/O interrupts.

INI(880) instruction: Changes high-speed counter PVs. (Clears them to 0.)

● Preparations

• PLC Setup

The high-speed counter inputs and interrupt inputs are set in the PLC Setup.

PLC Setup	
High-speed counter 1	Counter setting: Input pulse frequency (100 kHz max.) Counting Mode: Linear mode Reset Method: Z phase, software reset Comparing After Counter Reset: Stop Pulse Input Mode: Differential Phase (x4)
IN00	Input Operation: Interrupt Edge: Rising Edge Latch: High-speed counter 1
IN01	Input Operation: Interrupt Edge: Rising Edge Latch: High-speed counter 1

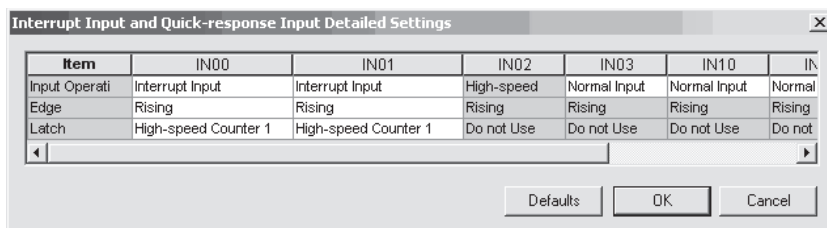
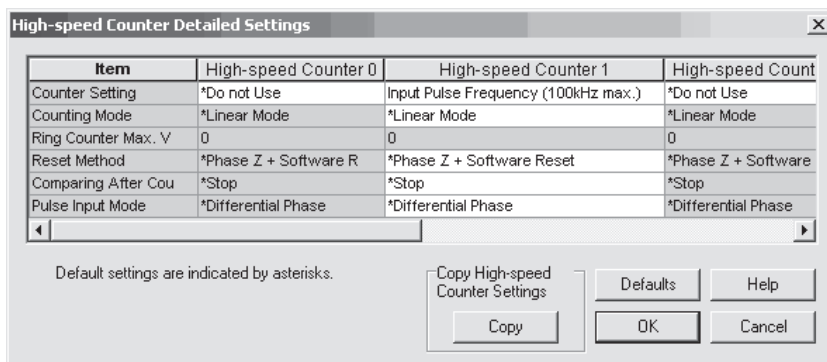
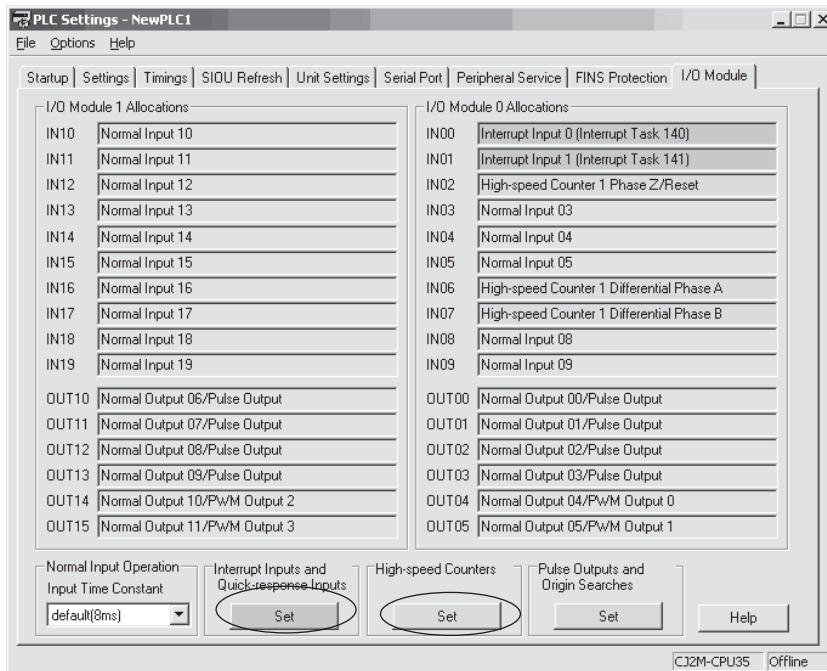

● Ladder Program

Cyclic Task (Task 0)

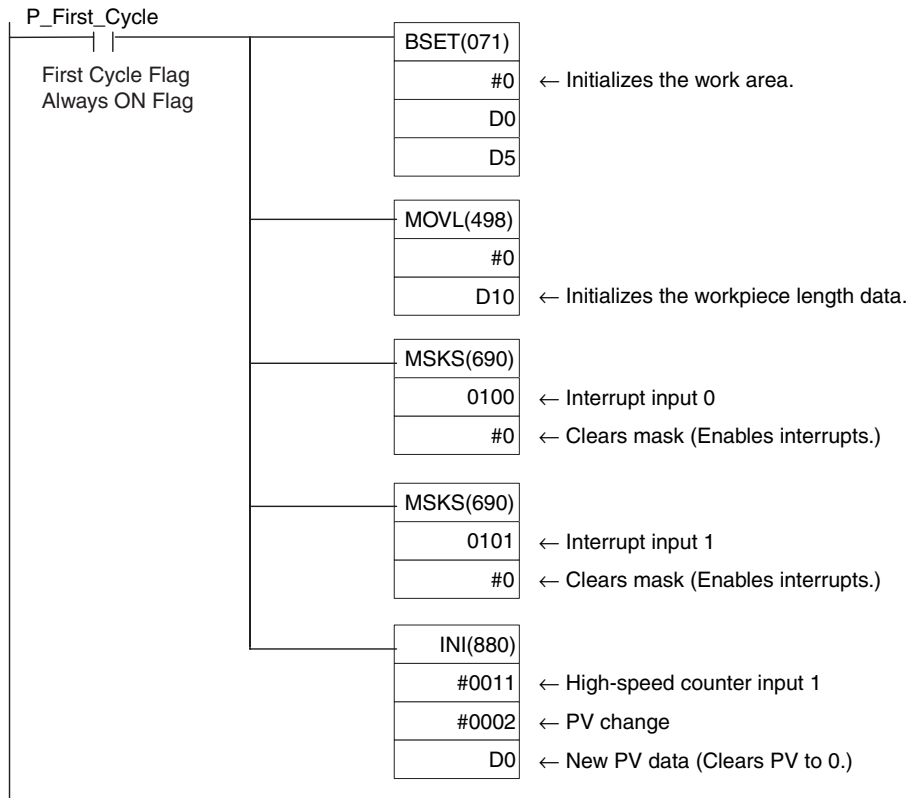

IN00 interrupt Task (interrupt Task 140)

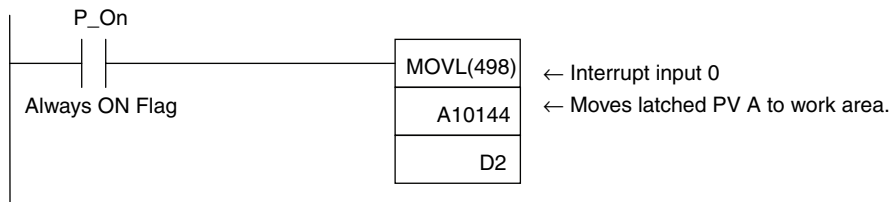

IN01 interrupt Task (interrupt Task 141)

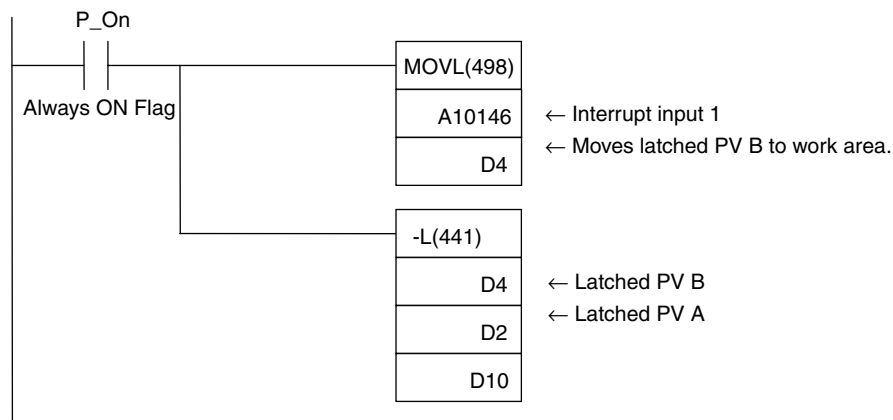

8

Pulse Outputs

This section describes positioning functions such as trapezoidal control, S-curve control, jogging, and origin searches.

8-1 Overview	8-3
8-1-1 Overview	8-3
8-1-2 Application Procedure	8-4
8-1-3 Specifications	8-5
8-1-4 Wiring	8-11
8-2 Position Control	8-27
8-2-1 Position Control Configuration	8-27
8-2-2 Relative Positioning and Absolute Positioning	8-28
8-2-3 Application Example	8-30
8-3 Jogging	8-32
8-3-1 High-speed Jogging	8-32
8-3-2 Low-speed Jogging	8-32
8-3-3 Application Example	8-33
8-4 Implementing Interrupt Feeding	8-35
8-4-1 Using the IFEED(892) (INTERRUPT FEEDING) Instruction	8-35
8-4-2 Setting Procedure	8-35
8-4-3 PLC Setup	8-36
8-4-4 INTERRUPT FEEDING Instruction: IFEED(892)	8-37
8-5 Defining the Origin	8-39
8-5-1 Origin Searches	8-39
8-5-2 Setting Procedure	8-40
8-5-3 PLC Setup	8-40
8-5-4 Origin Search Instructions	8-45
8-5-5 Origin Search Operations	8-46
8-5-6 Origin Return	8-51
8-5-7 Changing the PV of the Pulse Output	8-52
8-5-8 Application Example	8-52
8-6 Reading the Pulse Output Present Value	8-56
8-7 Reading the Pulse Output Frequency	8-57
8-8 Related Auxiliary Area Bits	8-58

- 8-9 Application Example 8-63**
 - 8-9-1 Cutting Long Material Using Fixed Feeding 8-63
 - 8-9-2 Palletize: Two-axis Multipoint Positioning 8-66
 - 8-9-3 Vertically Conveying PCBs (Multiple Progressive Positioning) 8-74
 - 8-9-4 Feeding Wrapping Material: Interrupt Feeding 8-80
- 8-10 Precautions when Using Pulse Outputs 8-82**
- 8-11 Pulse Output Patterns 8-87**
 - 8-11-1 Speed Control (Continuous Mode) 8-87
 - 8-11-2 Positioning Control (Independent Mode) 8-89

8-1 Overview

8-1-1 Overview

Pulse outputs can be output from the Pulse I/O Module's output terminals using instructions to perform positioning or speed control with a servomotor or a stepping motor that accepts pulse inputs. It is also possible to perform origin searches or origin returns.

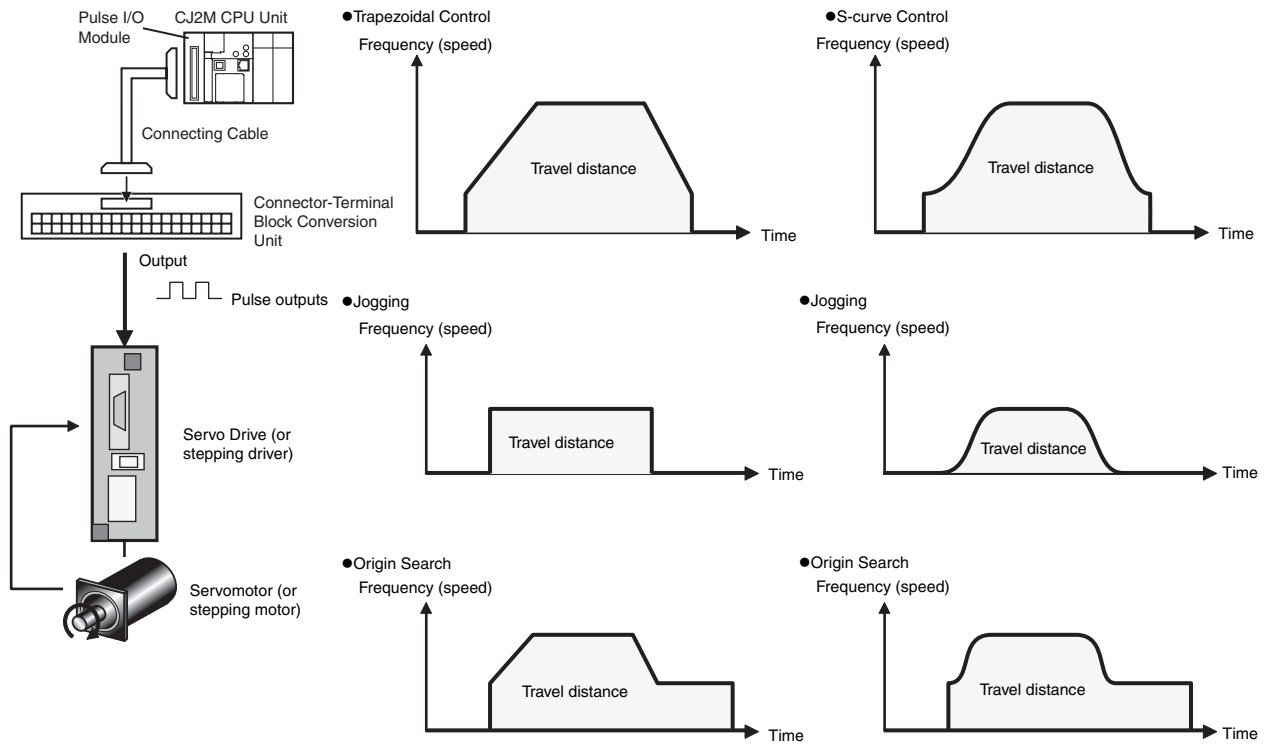

Positioning is performed with a servomotor or stepping motor in the following configuration.

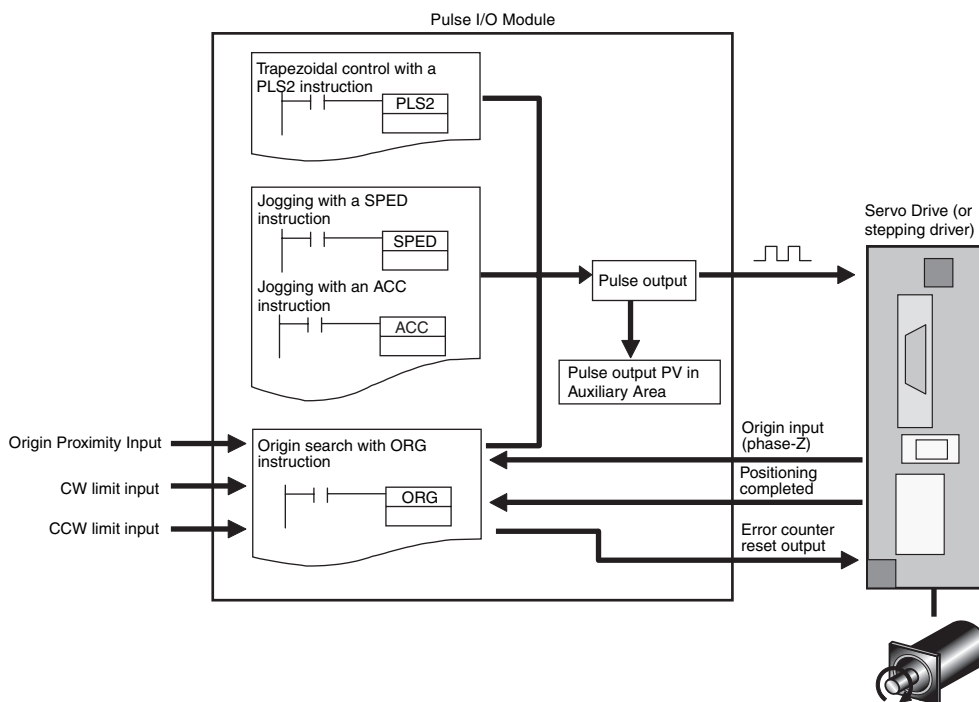

8-1-2 Application Procedure

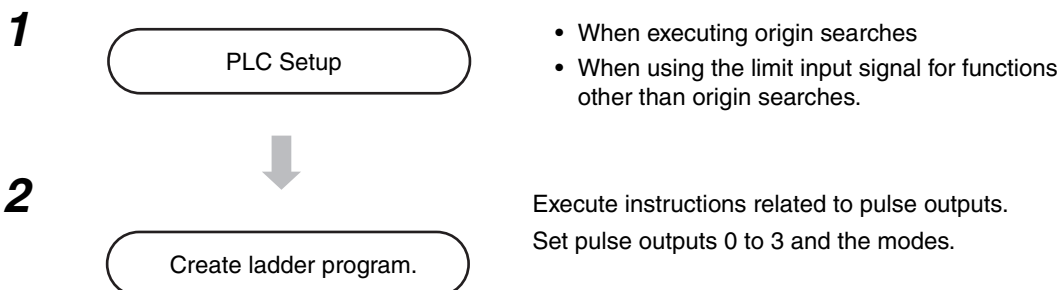

Applicable Output Terminals

The outputs listed in the following table can be used as pulse outputs.

The output terminals that are used for pulse outputs are also used for normal outputs and PWM outputs. The same output terminal can be used for only one of these functions.

For example, if pulse output 1 is used with pulse and direction outputs, normal output 1 cannot be used.

Pulse I/O Module No.	Terminal symbol	Word	Bit	Pulse output functions*			Other functions that cannot be used at the same time	
				CW/CCW outputs	Pulse + direction outputs	Origin search	Normal outputs	PWM outputs
0 (on the right)	OUT00	CIO 2961	00	CW pulse output 0	Pulse output 0	---	Normal output 0	---
	OUT01		01	CCW pulse output 0	Pulse output 1	---	Normal output 1	---
	OUT02		02	CW pulse output 1	Direction output 0	---	Normal output 2	---
	OUT03		03	CCW pulse output 1	Direction output 1	---	Normal output 3	---
	OUT04		04	---	---	Pulse output 0 error counter reset output (operation modes 1 and 2)	Normal output 4	PWM output 0
	OUT05		05	---	---	Pulse output 1 error counter reset output (operation modes 1 and 2)	Normal output 5	PWM output 1
1 (on the left)	OUT10	CIO 2963	00	CW pulse output 2	Pulse output 2	---	Normal output 6	---
	OUT11		01	CCW pulse output 2	Pulse output 3	---	Normal output 7	---
	OUT12		02	CW pulse output 3	Direction output 2	---	Normal output 8	---
	OUT13		03	CCW pulse output 3	Direction output 3	---	Normal output 9	---
	OUT14		04	---	---	Pulse output 2 error counter reset output (operation modes 1 and 2)	Normal output 10	PWM output 2
	OUT15		05	---	---	Pulse output 3 error counter reset output (operation modes 1 and 2)	Normal output 11	PWM output 3

* The pulse output method is specified with an operand in the Pulse Output Instruction.

8-1-3 Specifications

Item	Specifications
Output mode	Continuous mode (for speed control) or independent mode (for position control)
Positioning (independent mode) instructions	PULS(886) and SPED(885), PULS(886) and ACC(888), or PULS2(887) instruction
Speed control (continuous mode) instructions	SPED(885) and ACC(888) instructions
Origin (origin search and origin return) instructions	ORG(889) instruction
Interrupt feeding instruction	IFEED(892) instruction
Output frequency	1 pps to 100 kpps (1 pps units), two pulse outputs × 2 Pulse I/O Modules
Frequency acceleration and deceleration rates	Set in increments of 1 pps for acceleration/deceleration rates from 1 to 65,535 pps (every 4 ms). The acceleration and deceleration rates can be set independently only with the PLS2 instruction.
Internal pulse control cycle	1 ms or 4 ms (Set in the PLC Setup.)
Changing SVs during instruction execution	The target frequency, acceleration/deceleration rate, and target position can be changed.
Pulse output method	CW/CCW or pulse + direction
Number of output pulses	Relative coordinates: 0000 0000 to 7FFF FFFF hex (Accelerating or decelerating in either direction: 2,147,483,647) Absolute coordinates: 8000 0000 to 7FFF FFFF hex (-2,147,483,648 to 2,147,483,647)
Relative/absolute coordinate specifications for pulse output PVs	Absolute coordinates are specified automatically when the origin location has been defined by changing the pulse output PV with the INI(880) instruction or performing an origin search with the ORG(889) instruction. Relative coordinates must be used when the origin is undefined.
Relative pulse/absolute pulse specifications	The pulse type can be specified with an operand in the PULS(886) or PLS2(887) instruction. Absolute pulses can be used when absolute coordinates are specified for the pulse output PV, i.e. the origin location has been defined. Absolute pulse cannot be used when relative coordinates are specified, i.e., when the origin location is undefined. An instruction error will occur.
Pulse output PV's storage location	The following Auxiliary Area words contain the pulse output PVs Pulse output 0: A277 (leftmost 4 digits) and A276 (rightmost 4 digits) Pulse output 1: A279 (leftmost 4 digits) and A278 (rightmost 4 digits) Pulse output 2: A323 (leftmost 4 digits) and A322 (rightmost 4 digits) Pulse output 3: A325 (leftmost 4 digits) and A324 (rightmost 4 digits) The PVs are refreshed during regular I/O refreshing.

PLC Setup

To perform an origin search or to use a limit input signal as an input to a function other than an origin search, click the **Set** Button in the Pulse Outputs and Origin Searches Area on the I/O Module Tab Page in the PLC Setup and make the settings in the Pulse Output and Origin Search Detailed Settings Dialog Box.

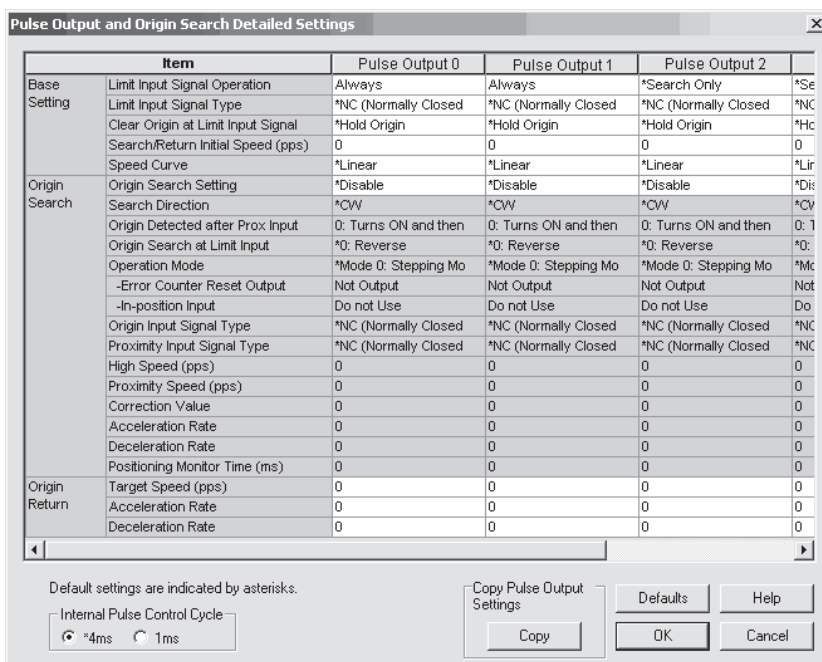
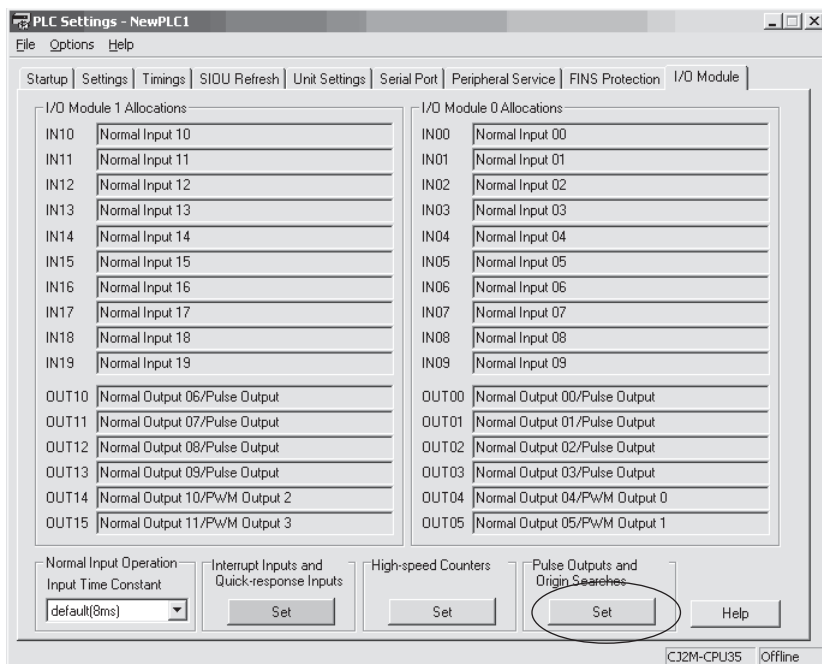

Pulse Output and Origin Search Detailed Settings

Item		Selection	Description
Internal pulse control cycle		4 ms	Sets the control cycle for the pulse output to 4 ms.
		1 ms	Sets the control cycle for the pulse output to 1 ms.
Base Setting	Limit Input Signal Operation	Search Only	The CW/CCW limit input signal is used for origin searches only.
		Always	The CW/CCW limit input signal is used by functions other than origin search.
	Limit Input Signal Type	NC (Normally Closed)	Select when using NC contacts for the limit input signal.
		NO (Normally Open)	Select when using NO contacts for the limit input signal.
	Clear Origin at Limit Input Signal	Hold Origin	When a limit input signal is input, the pulse output is stopped and the previous status is held.
		Clear Origin	When a limit input signal is input, the pulse output is stopped and origin becomes undefined.
	Search/Return Initial Speed (pps)	Set the motor's starting speed when performing an origin search. Specify the speed in the number of pulses per second (pps).	
	Speed Curve	Linear	Select this option to use trapezoidal acceleration/deceleration rates for pulse output with acceleration/deceleration.
S-curve		Select this option to use S-curve acceleration/deceleration rates for pulse output with acceleration/deceleration.	

Note The power supply must be restarted after the PLC Setup is transferred in order to enable the pulse output settings.

Refer to *8-5 Defining the Origin* for information on the origin search settings in the PLC Setup.

Setting the Pulse Output Port Number and Assigning Pulse Output Terminals

● Pulse Output Method

The CW/CCW pulse outputs or pulse plus direction outputs can be used as the pulse output method. The pulse output method is specified with an operand in the Pulse Output Instruction.

CW/CCW Pulse Output

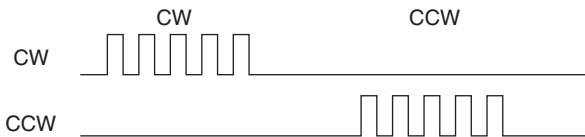

Pulse and Direction Outputs

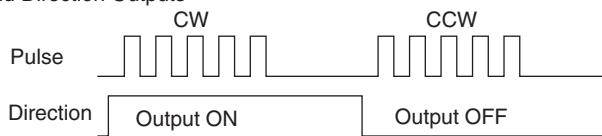

● Pulse Output Port Numbers and Pulse Output Terminals

The following terminals are used for pulse outputs according to the pulse output port number.

Pulse I/O Module No.	Terminal symbol	Output bit		Pulse output functions*			Other functions that cannot be used at the same time	
		Word	Bit	CW/CCW outputs	Pulse + direction outputs	Origin search	Normal outputs	PWM outputs
0 (on the right)	OUT00	CIO 2961	00	CW pulse output 0	Pulse output 0	---	Normal output 0	---
	OUT01		01	CCW pulse output 0	Pulse output 1	---	Normal output 1	---
	OUT02		02	CW pulse output 1	Direction output 0	---	Normal output 2	---
	OUT03		03	CCW pulse output 1	Direction output 1	---	Normal output 3	---
1 (on the left)	OUT10	CIO 2963	00	CW pulse output 2	Pulse output 2	---	Normal output 6	---
	OUT11		01	CCW pulse output 2	Pulse output 3	---	Normal output 7	---
	OUT12		02	CW pulse output 3	Direction output 2	---	Normal output 8	---
	OUT13		03	CCW pulse output 3	Direction output 3	---	Normal output 9	---

* The pulse output method is specified with an operand in the Pulse Output Instruction.

Origin Searches

Use the following input and output terminals for origin searches.

- Inputs

Pulse I/O Module No.	Terminal symbol	Input bit		Function	Other functions that cannot be used at the same time			
		Word	Bit		Origin search	Normal inputs	Interrupt inputs	Quick-response inputs
0 (on the right)	IN00	CIO 2960	00	Pulse output 0 origin input signal (always)	Normal input 0	Interrupt input 0	Quick-response input 0	---
	IN01		01	Pulse output 0 origin proximity input signal (origin detection method: 0 or 1)	Normal input 1	Interrupt input 1	Quick-response input 1	---
	IN02		02	Pulse output 1 origin input signal (always)	Normal input 2	Interrupt input 2	Quick-response input 2	Counter 1 phase Z or reset input
	IN03		03	Pulse output 1 origin proximity input signal (origin detection method 0 or 1)	Normal input 3	Interrupt input 3	Quick-response input 3	Counter 0 phase Z or reset input
	IN04		04	Pulse output 0 positioning completed signal (operation mode: 2)	Normal input 4	---	---	---
	IN05		05	Pulse output 1 positioning completed signal (operation mode 2)	Normal input 5	---	---	---

Pulse I/O Module No.	Terminal symbol	Input bit		Function	Other functions that cannot be used at the same time			
		Word	Bit		Origin search	Normal inputs	Interrupt inputs	Quick-response inputs
1 (on the left)	IN10	CIO 2962	00	Pulse output 2 origin input signal (always)	Normal input 10	Interrupt input 4	Quick-response input 4	---
	IN11		01	Pulse output 2 origin proximity input signal (origin detection method 0 or 1)	Normal input 11	Interrupt input 5	Quick-response input 5	---
	IN12		02	Pulse output 3 origin input signal (always)	Normal input 12	Interrupt input 6	Quick-response input 6	Counter 3 phase Z or reset input
	IN13		03	Pulse output 3 origin proximity input signal (origin detection method 0 or 1)	Normal input 13	Interrupt input 7	Quick-response input 7	Counter 2 phase Z or reset input
	IN14		04	Pulse output 2 positioning completed signal (operation mode 2)	Normal input 14	---	---	---
	IN15		05	Pulse output 3 positioning completed signal (operation mode 2)	Normal input 15	---	---	---

- Outputs

Pulse I/O Module No.	Terminal symbol	Output bit		Function	Other functions that cannot be used at the same time	
		Word	Bit		Origin search	Normal outputs
0 (on the right)	OUT04	CIO 2961	04	Pulse output 0 error counter reset output (operation modes 1 and 2)	Normal output 4	PWM output 0
	OUT05		05	Pulse output 1 error counter reset output (operation modes 1 and 2)	Normal output 5	PWM output 1
1 (on the left)	OUT14	CIO 2963	04	Pulse output 2 error counter reset output (operation modes 1 and 2)	Normal output 10	PWM output 2
	OUT15		05	Pulse output 3 error counter reset output (operation modes 1 and 2)	Normal output 11	PWM output 3



Additional Information

When using an origin search in operation mode 0, outputs 4, 5, 10, and 11 can be used as PWM outputs or normal outputs.

8-1-4 Wiring

Connector Pin Assignments

● CW/CCW Outputs

Sinking-type Pulse I/O Module (CJ2M-MD211)

Pulse I/O Module No. 0 (on the right)					Pulse I/O Module No. 1 (on the left)				
Output type and number	Terminal symbol	Pin	(*)	Description	Output type and number	Terminal symbol	Pin	(*)	Description
Pulse output 0	OUT00	31	A16	CW pulse output	Pulse output 2	OUT10	31	A16	CW pulse output
	OUT01	32	B16	CCW pulse output		OUT11	32	B16	CCW pulse output
Pulse output 1	OUT02	33	A17	CW pulse output	Pulse output 3	OUT12	33	A17	CW pulse output
	OUT03	34	B17	CCW pulse output		OUT13	34	B17	CCW pulse output
---		37	A19	Power supply input +V for outputs	---		37	A19	Power supply input +V for outputs
		38	B19				38	B19	
---		39	A20	COM	---		39	A20	COM
		40	B20				40	B20	

* Terminal numbers on the XW2D-□□G□ Connector-Terminal Block Conversion Unit.

Sourcing-type Pulse I/O Module (CJ2M-MD212)

Pulse I/O Module No. 0 (on the right)					Pulse I/O Module No. 1 (on the left)				
Output type and number	Terminal symbol	Pin	(*)	Description	Output type and number	Terminal symbol	Pin	(*)	Description
Pulse output 0	OUT00	31	A16	CW pulse output	Pulse output 2	OUT10	31	A16	CW pulse output
	OUT01	32	B16	CCW pulse output		OUT11	32	B16	CCW pulse output
Pulse output 1	OUT02	33	A17	CW pulse output	Pulse output 3	OUT12	33	A17	CW pulse output
	OUT03	34	B17	CCW pulse output		OUT13	34	B17	CCW pulse output
---		37	A19	COM	---		37	A19	COM
		38	B19				38	B19	
---		39	A20	Power supply input -V for outputs	---		39	A20	Power supply input -V for outputs
		40	B20				40	B20	

* Terminal numbers on the XW2D-□□G□ Connector-Terminal Block Conversion Unit.

● Pulse + Direction Outputs

Sinking-type Pulse I/O Module (CJ2M-MD211)

Pulse I/O Module No. 0 (on the right)					Pulse I/O Module No. 1 (on the left)				
Output type and number	Terminal symbol	Pin	(*)	Description	Output type and number	Terminal symbol	Pin	(*)	Description
Pulse output 0	OUT00	31	A16	Pulse output	Pulse output 2	OUT10	31	A16	Pulse output
	OUT02	33	A17	Direction output		OUT12	33	A17	Direction output
Pulse output 1	OUT01	32	B16	Pulse output	Pulse output 3	OUT11	32	B16	Pulse output
	OUT03	34	B17	Direction output		OUT13	34	B17	Direction output
---		37	A19	Power supply input +V for outputs	---		37	A19	Power supply input +V for outputs
		38	B19				38	B19	
---		39	A20	COM	---		39	A20	COM
		40	B20				40	B20	

* Terminals numbers on the XW2D-□□G□ Connector-Terminal Block Conversion Unit.

Sourcing-type Pulse I/O Module (CJ2M-MD212)

Pulse I/O Module No. 0 (on the right)					Pulse I/O Module No. 1 (on the left)				
Output type and number	Terminal symbol	Pin	(*)	Description	Output type and number	Terminal symbol	Pin	(*)	Description
Pulse output 0	OUT00	31	A16	Pulse output	Pulse output 2	OUT10	31	A16	Pulse output
	OUT02	33	A17	Direction output		OUT12	33	A17	Direction output
Pulse output 1	OUT01	32	B16	Pulse output	Pulse output 3	OUT11	32	B16	Pulse output
	OUT03	34	B17	Direction output		OUT13	34	B17	Direction output
---		37	A19	COM	---		37	A19	COM
		38	B19				38	B19	
---		39	A20	Power supply input -V for outputs	---		39	A20	Power supply input -V for outputs
		40	B20				40	B20	

* Terminals numbers on the XW2D-□□G□ Connector-Terminal Block Conversion Unit.

Connecting the Servo Drive and External Sensors

● Connections for Pulse Output 0

Pulse I/O Module No.	Terminal symbol	Terminals		Bit	Signal	Origin search				
		Pin	(*)			Operation mode 0	Operation mode 1	Operation mode 2		
0 (on the right)	OUT00	31	A16	CIO 2961.00	CW/CCW Outputs	CW	Connect to Servo Drive's pulse input (CW).			
	OUT01	32	B16	CIO 2961.01		CCW	Connect to Servo Drive's pulse input (CWW).			
	OUT00	31	A16	CIO 2961.00	Pulse and Direction Outputs	Pulse	Connect to Servo Drive's pulse input (PULS(886)).			
	OUT02	33	A17	CIO 2961.02		Direction	Connect to Servo Drive's direction input (SIGN).			
	---	Normal input		The external signal must be received as an input and the input status must be written to A540.08 in the ladder program.		CW limit sensor		Connect sensor to a normal input terminal.		
	---	Normal input		The external signal must be received as an input and the input status must be written to A540.09 in the ladder program.		CCW limit sensor		Connect sensor to a normal input terminal.		
	IN00	1	A1	CIO 2960.00		Origin input		Connect to sensor.	Connect to the phase-Z signal from the Servo Drive.	Connect to the phase-Z signal from the Servo Drive.
	IN01	2	B1	CIO 2960.01		Origin proximity input		Connect to sensor.		
	OUT04	35	A18	CIO 2961.04		Error counter reset output		Not used.	Connect to error counter reset (ECRST) of the Servo Drive.	
	IN04	13	A7	CIO 2960.04		Positioning completed signal (INP)		Not used.	Connect to the positioning completed signal (INP) from the Servo Drive.	

* Terminals numbers on the XW2D-□□G□ Connector-Terminal Block Conversion Unit.

● Connections for Pulse Output 1

Pulse I/O Module No.	Terminal symbol	Terminals		Bit		Signal		Origin search		
		Pin	(*)					Operation mode 0	Operation mode 1	Operation mode 2
0 (on the right)	OUT02	33	A17	CIO 2961.02	PV stored in A278 and A279.	CW/CCW outputs	CW	Connect to Servo Drive's pulse input (CW).		
	OUT03	34	B17	CIO 2961.03			CCW	Connect to Servo Drive's pulse input (CWW).		
	OUT01	32	B16	CIO 2961.01	PV stored in A278 and A279.	Pulse and Direction Outputs	Pulse	Connect to Servo Drive's pulse input (PULS(886)).		
	OUT03	34	B17	CIO 2961.03			Direction	Connect to Servo Drive's direction input (SIGN).		
	---	Normal input		The external signal must be received as an input and the input status must be written to A541.08 in the ladder program.		CW limit sensor		Connect sensor to a normal input terminal.		
	---	Normal input		The external signal must be received as an input and the input status must be written to A541.09 in the ladder program.		CCW limit sensor		Connect sensor to a normal input terminal.		
	IN02	7	A4	CIO 2960.02		Origin input		Connect to sensor.	Connect to the phase-Z signal from the Servo Drive.	Connect to the phase-Z signal from the Servo Drive.
	IN03	8	B4	CIO 2960.03		Origin proximity input		Connect to sensor.		
	OUT05	36	B18	CIO 2961.05		Error counter reset output		Not used.	Connect to error counter reset (ECRST) of the Servo Drive.	
IN05	14	B7	CIO 2960.05		Positioning completed signal (INP)		Not used.		Connect to the positioning completed signal (INP) from the Servo Drive.	

* Terminals numbers on the XW2D-□□G□ Connector-Terminal Block Conversion Unit.

● Connections for Pulse Output 2

Pulse I/O Module No.	Terminal symbol	Terminals		Bit		Signal		Origin search		
		Pin	(*)					Operation mode 0	Operation mode 1	Operation mode 2
1 (on the left)	OUT10	31	A16	CIO 2963.00	PV stored in A322 and A323.	CW/CCW	CW	Connect to Servo Drive's pulse input (CW).		
	OUT11	32	B16	CIO 2963.01			CCW	Connect to Servo Drive's pulse input (CCW).		
	OUT10	31	A16	CIO 2963.00	PV stored in A322 and A323.	Pulse and Direction Outputs	Pulse	Connect to Servo Drive's pulse input (PULS(886)).		
	OUT12	33	A17	CIO 2963.02			Direction	Connect to Servo Drive's pulse input (SIGN).		
	---	Normal input		The external signal must be received as an input and the input status must be written to A542.08 in the ladder program.		CW limit sensor		Connect sensor to a normal input terminal.		
	---	Normal input		The external signal must be received as an input and the input status must be written to A542.09 in the ladder program.		CCW limit sensor		Connect sensor to a normal input terminal.		
	IN10	1	A1	CIO 2962.00		Origin input		Connect to sensor.	Connect to the phase-Z signal from the Servo Drive.	Connect to the phase-Z signal from the Servo Drive.
	IN11	2	B1	CIO 2962.01		Origin proximity input		Connect to sensor.		
	OUT14	35	A18	CIO 2963.04		Error counter reset output		Not used.	Connect to error counter reset (ECRST) of the Servo Drive.	
IN14	13	A7	CIO 2962.04		Positioning completed signal (INP)		Not used.		Connect to the positioning completed signal (INP) from the Servo Drive.	

* Terminals numbers on the XW2D-□□G□ Connector-Terminal Block Conversion Unit.

● Connections for Pulse Output 3

Pulse I/O Module No.	Terminal symbol	Terminals		Bit	Signal	Origin search				
		Pin	(*)			Operation mode 0	Operation mode 1	Operation mode 2		
1 (on the left)	OUT12	33	A17	CIO 2963.02	PV stored in A324 and A325.	CW/CCW	CW	Connect to Servo Drive's pulse input (CW).		
	OUT13	34	B17	CIO 2963.03			CCW	Connect to Servo Drive's pulse input (CCW).		
	OUT11	32	B16	CIO 2963.01	PV stored in A324 and A325.	Pulse and Direction Outputs	Pulse	Connect to Servo Drive's pulse input (PULS(886)).		
	OUT13	34	B17	CIO 2963.03			Direction	Connect to Servo Drive's pulse input (SIGN).		
	---	Normal inputs		The external signal must be received as an input and the input status must be written to A543.08 in the ladder program.		CW limit sensor		Connect sensor to a normal input terminal.		
	---	Normal inputs		The external signal must be received as an input and the input status must be written to A543.09 in the ladder program.		CCW limit sensor		Connect sensor to a normal input terminal.		
	IN12	7	A4	CIO 2962.02		Origin input		Connect to sensor.	Connect to the phase-Z signal from the Servo Drive.	Connect to the phase-Z signal from the Servo Drive.
	IN13	8	B14	CIO 2962.03		Origin proximity input		Connect to sensor.		
	OUT15	36	B18	CIO 2963.05		Error counter reset output		Not used.	Connect to error counter reset (ECRST) of the Servo Drive.	
IN15	14	B7	CIO 2962.05		Positioning completed signal (INP)		Not used.		Connect to the positioning completed signal (INP) from the Servo Drive.	

* Terminals numbers on the XW2D-□□G□ Connector-Terminal Block Conversion Unit.

Output Connection Examples

This section provides examples of connections to motor drives. Refer to the specifications for the motor drive being used before actually connecting a motor drive.

The cable length between the Pulse I/O Module and motor drive must not exceed 3 m.

When the pulse output's output transistor is OFF, pulses are not being output.

When the direction output is OFF, it indicates a CCW output.

Do not share the pulse output's power supply (24 VDC or 5 VDC) with any other I/O applications.

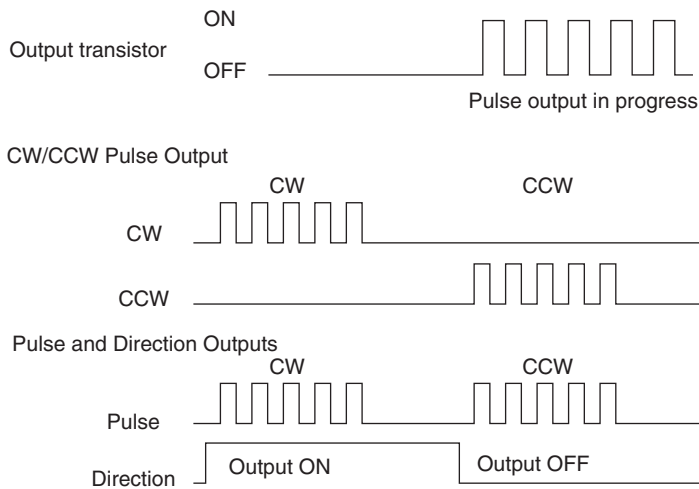

● CW/CCW Pulse Outputs and Pulse plus Direction Outputs

- Using a Motor Drive with 24-VDC Photocoupler Inputs

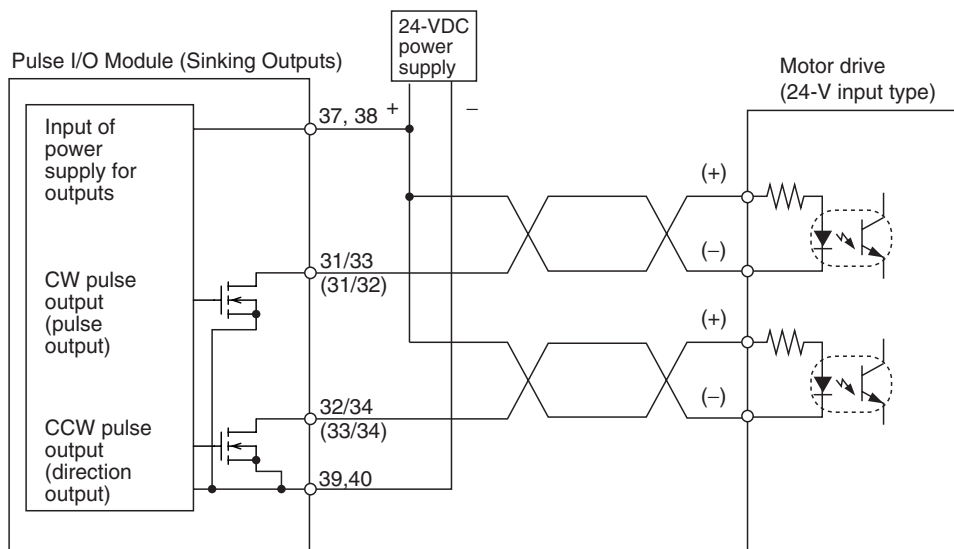

Note The terms in parentheses are for pulse + direction outputs.

● Using a Motor Drive with 5-VDC Photocoupler Input

• Connection Example 1

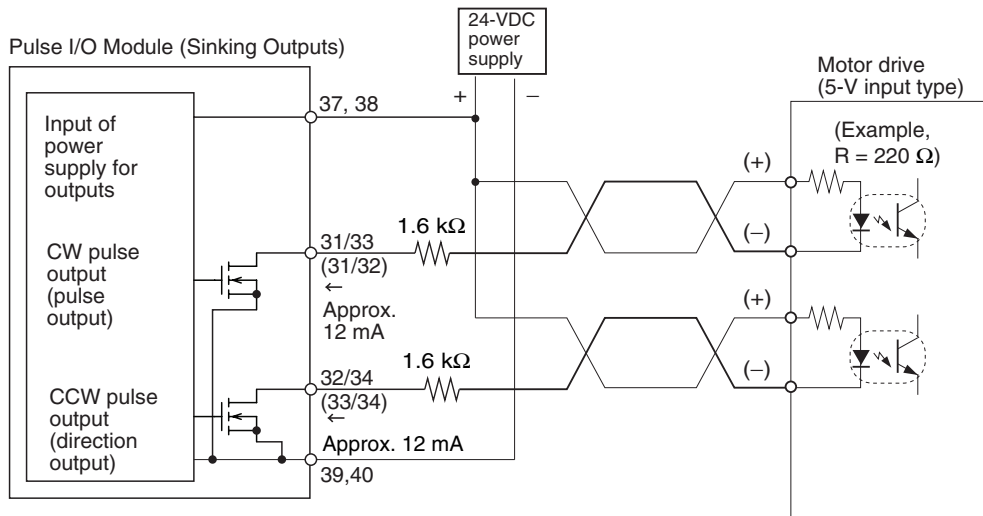

Note The terms in parentheses are for pulse + direction outputs.

In this example, the 24-VDC power supply is used for the motor drive with 5-V inputs. Verify that the Position Control Unit's output current will not damage the motor drive's input circuits. Also verify that the inputs turn ON properly.

Check that the 1.6-kΩ resistors have sufficient power derating.

• Connection Example 2

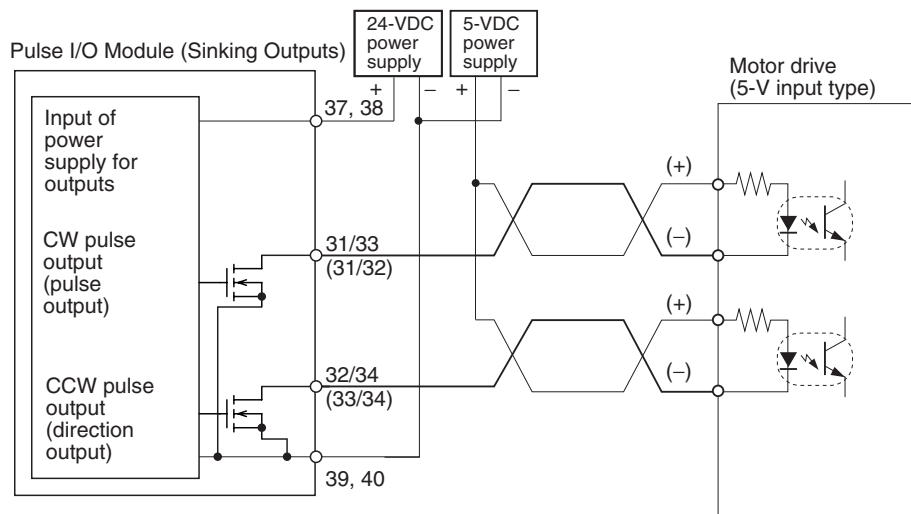

Note The terms in parentheses are for pulse + direction outputs.



Precautions for Correct Use

When the output is being used as a pulse output, connect a load that requires an output current between 7 and 30 mA.

The Unit's internal components may be damaged if the current exceeds 30 mA.

If the current is below 7 mA, the output waveform's rising edge and falling edge will be delayed and the output frequency ratings may not be met. If the load requires less than 7 mA, install a bypass resistor so that the circuit draws a current greater than 7 mA (10 mA is recommended.)

Use the following equations to determine the bypass resistor requirements.

$$R \leq \frac{V_{CC}}{I_{OUT} - I_{IN}}$$

$$\text{Power } W \geq \frac{V_{CC}^2}{R} \times 4 \text{ (Tolerance)}$$

V_{CC} : Output voltage (V)

I_{OUT} : Output current (A)
(7 to 30 mA)

I_{IN} : Drive input current

R: Bypass resistance (Ω)

Circuit Example

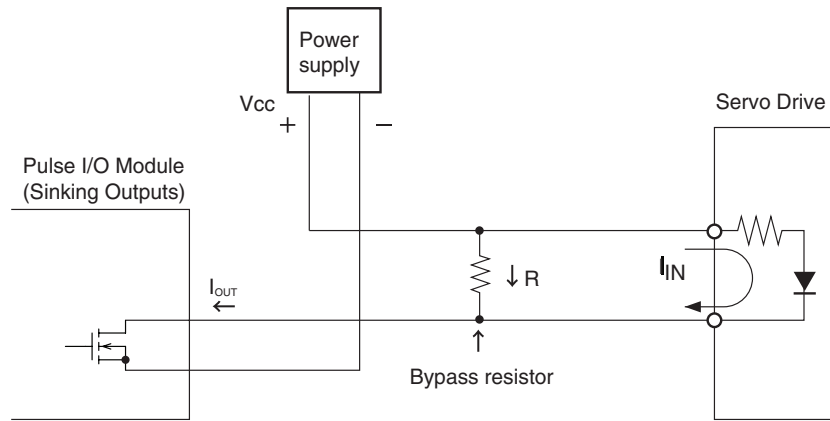

● Connection Example for the Error Counter Reset Output

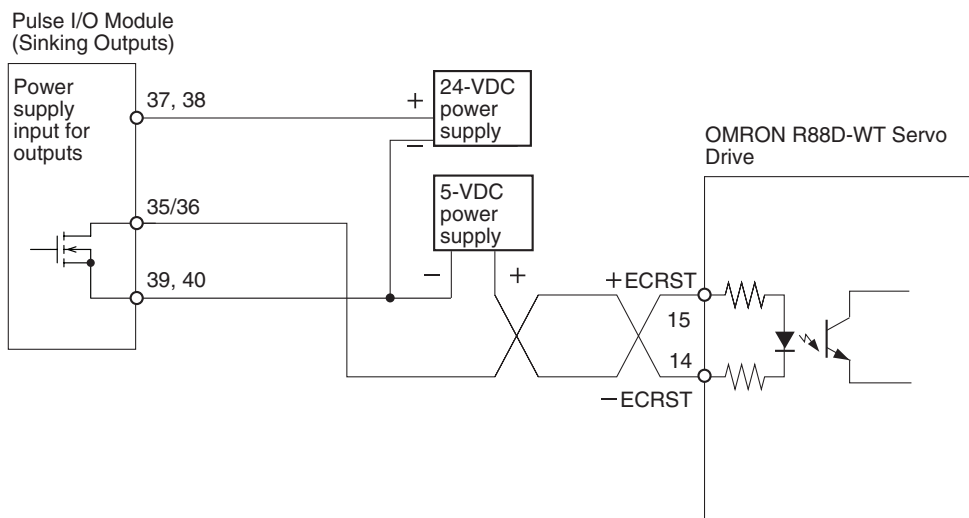

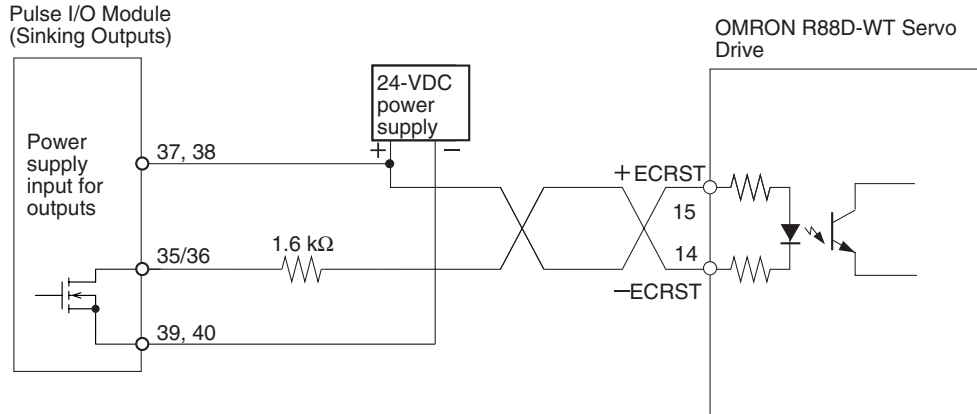

Motor Drive Connection Examples

This section provides examples of connections to pulse output 0 or 2. Refer to *3-2-1 Connector Pin Allocations* when using pulse output 1 or 3.

When using an OMRON Servo Drive, a Servo Relay Unit can be used to connect more easily. For the configuration when using a Servo Relay Unit, refer to *Using Servo Relay Units (Sinking Outputs Only)* on page 3-11.

When connecting to a stepping motor or a servo drive from another company, refer to *Using Connector-Terminal Block Conversion Units* on page 3-9 or *Directly Connecting a Self-made Cable with a Connector* on page 3-15.



Precautions for Correct Use

- Any NC input terminals for unused inputs should be connected to the power supply and turned ON.
- Use shielded cable for connections to stepping motor drives and servo drives. Attach the shield to the FG terminals at both the Position Control Unit end and drive end of the cable.
- The length of the cable connecting the motor drive must not exceed 3 m.

● Connection Example for Operation Mode 0

In operation mode 0, the origin location is determined when the rising edge of the origin input signal is detected (up-differentiation.) The error counter reset output and positioning completed signal are not used.

In this example, a stepping motor drive is used and a sensor is connected to the origin input signal terminal.

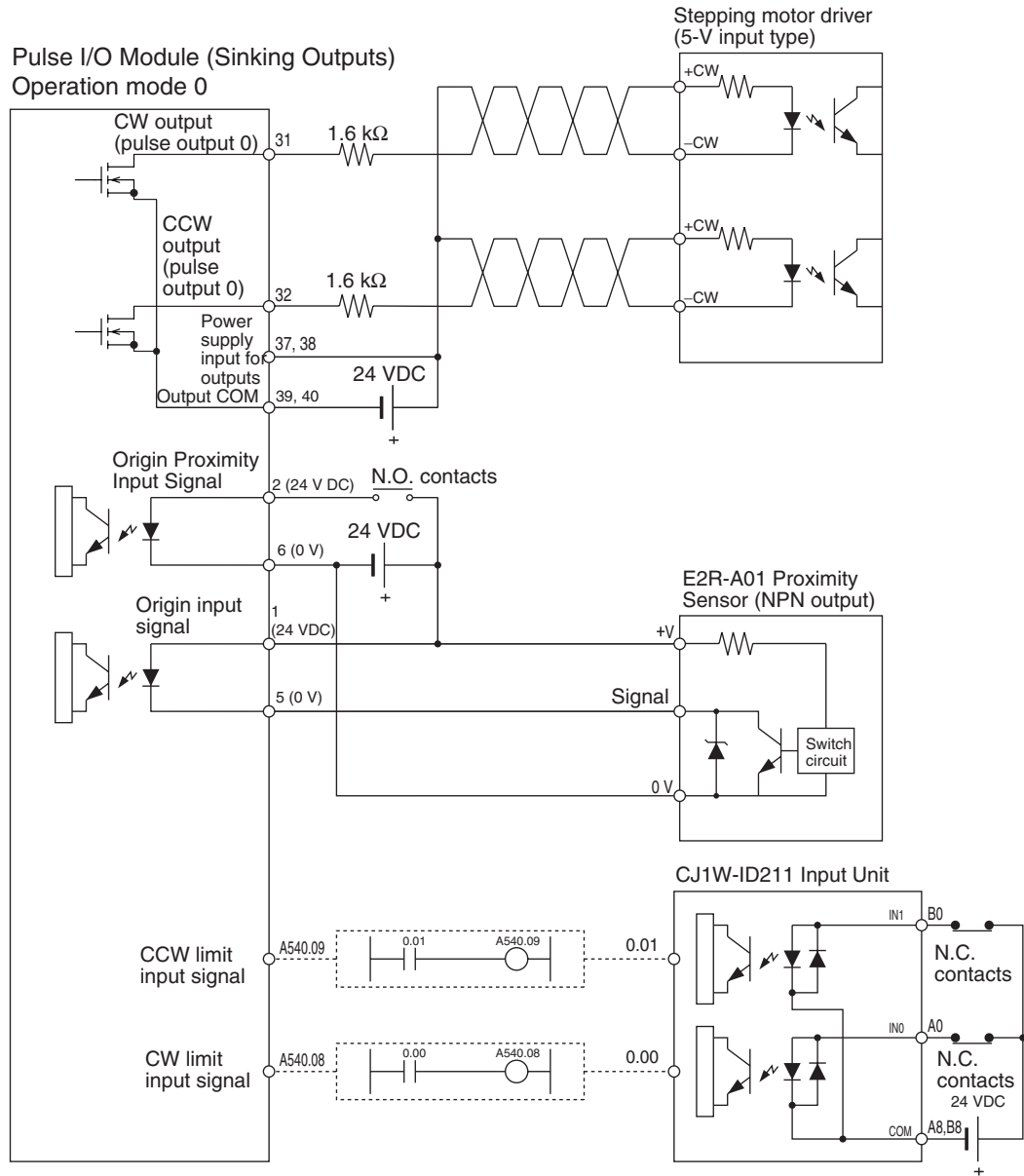

● Connection Example for Operation Mode 1

In operation mode 1, the error counter reset output is turned ON when the origin location is determined by detection of the rising edge of the origin input signal.

In this example, a servo drive is used and the encoder's phase-Z output is used as the origin input signal terminal. The servo drive is an OMRON G5-series Servo Drive.

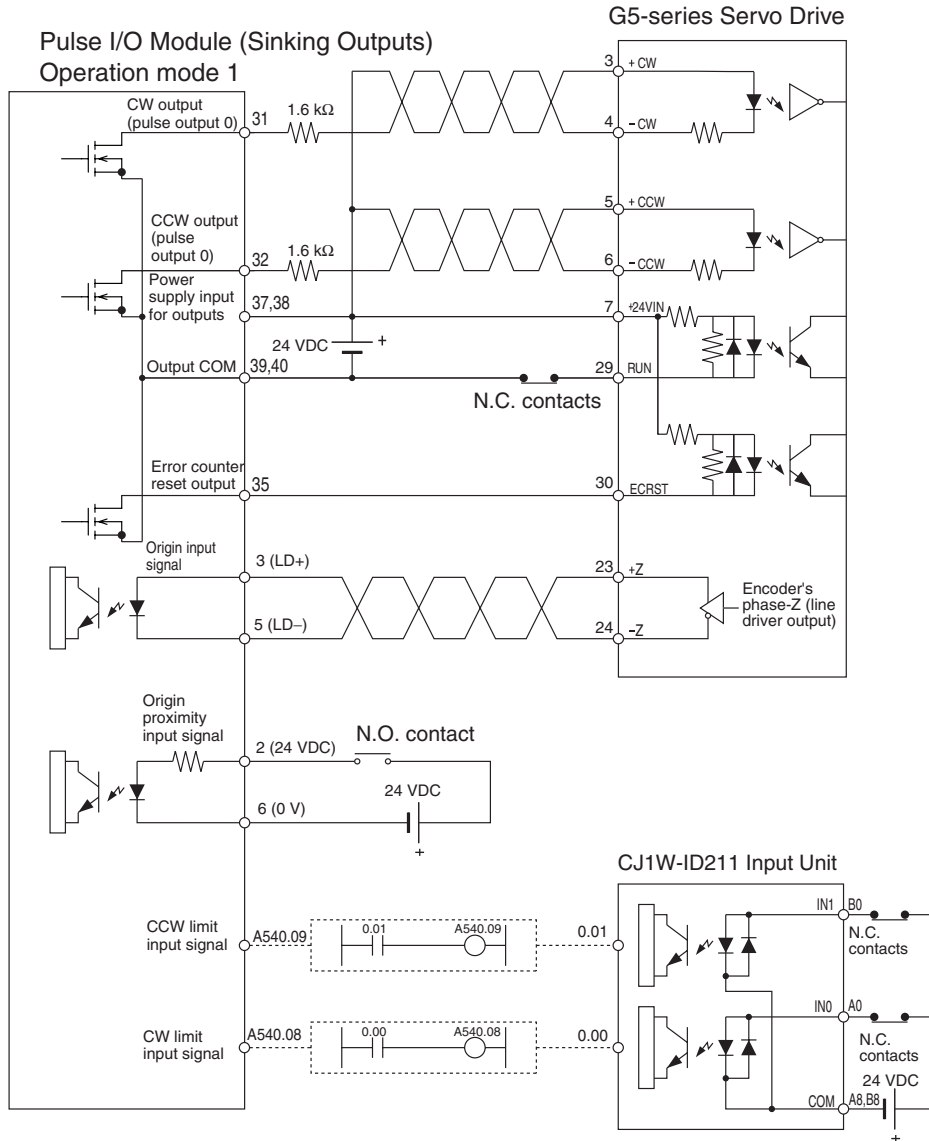

● Connection Example for Operation Mode 2

Operation mode 2 is the same as operation mode 1 except that the servo drive's positioning completed signal (INP) is used as the origin search's positioning completed signal.

A servo drive is used and the encoder's phase-Z output is used as the origin input signal terminal.

Set the Servo Drive so that the positioning completed signal is OFF when the motor is operating and ON when the motor is stopped. The origin search operation won't end if the positioning completed signal is not connected correctly from the Servo Drive or is not set correctly.

The servo drive is an OMRON G5-series Servo Drive.

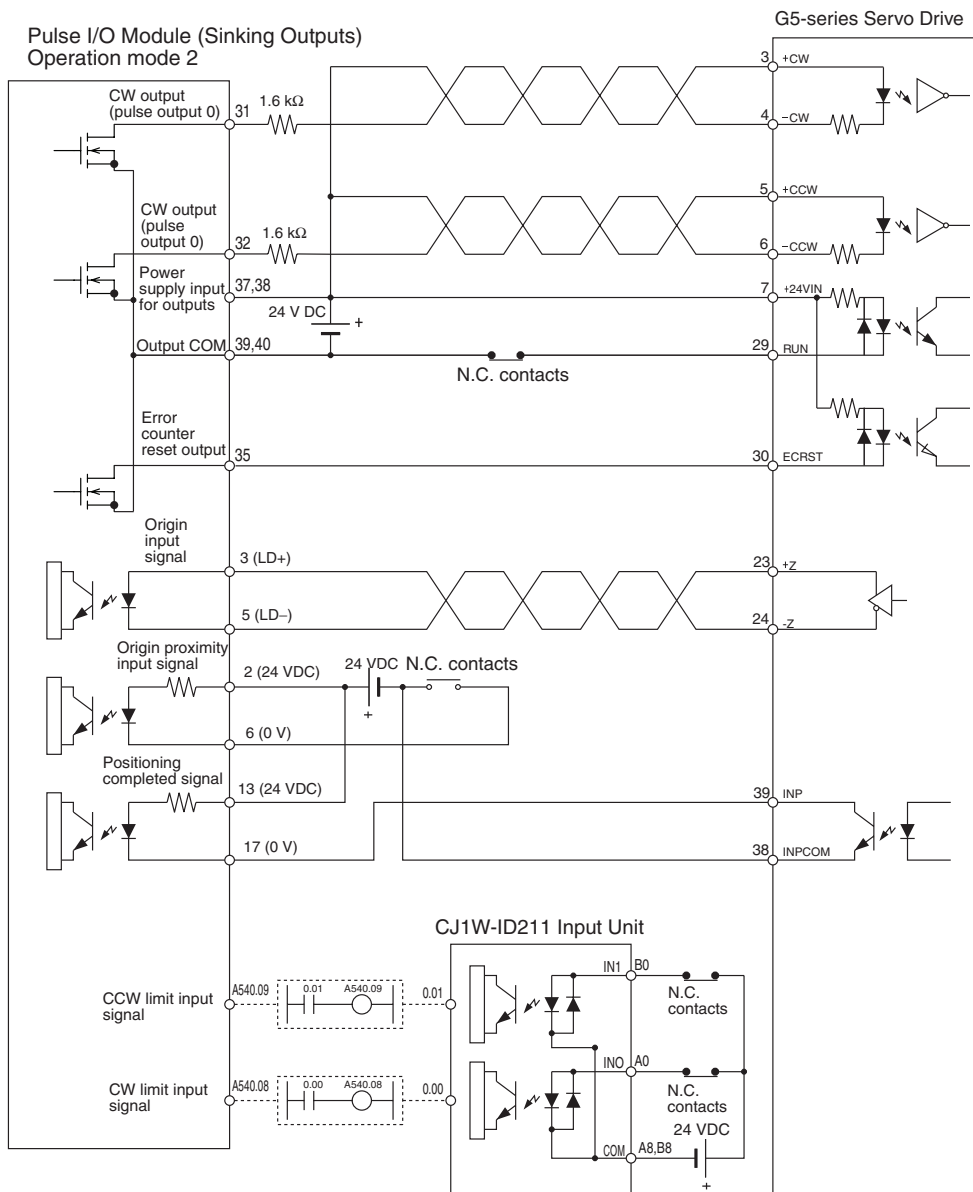

Executing Pulse Control Instructions in a Ladder Program

The pulse outputs are used by executing pulse control instructions in the ladder program.

● Applicable Instructions

The following instructions are used.

Purpose		Overview	Instruction	Reference
Performing trapezoidal or S-curve control		Performs trapezoidal or S-curve pulse output control with independent acceleration and deceleration rates. (The number of pulses can be set.)	ACC(888) (ACCELERATION CONTROL) PLS2(887) (PULSE OUTPUT)	Refer to 8-2 <i>Position Control</i>
Jogging	Without acceleration and deceleration	Performs pulse output control without acceleration or deceleration.	SPED(885) (SPEED OUTPUT)	Refer to 8-3 <i>Jogging</i>
	With acceleration and deceleration	Performs trapezoidal pulse output control with the same acceleration and deceleration rates.	ACC(888) (ACCELERATION CONTROL)	
Performing origin searches		Actually moves the motor with pulse outputs and defines the machine origin based on the origin proximity input and origin input signals.	ORG(889) (ORIGIN SEARCH)	Refer to 8-5-4 <i>Origin Search Instructions</i>
Performing origin returns		Returns to the origin position from any position.	ORG(889) (ORIGIN SEARCH)	Refer to 8-6 <i>Reading the Pulse Output Present Value</i>
Changing or reading the pulse output PV	Changes the PV of the pulse output. (This operation defines the origin location.)		INI(880) (MODE CONTROL)	Refer to 8-5-7 <i>Changing the PV of the Pulse Output</i>
	Reads the PV of the pulse output		PRV(881) (HIGH-SPEED COUNTER PV READ)	Refer to 8-6 <i>Reading the Pulse Output Present Value</i>
Performing interrupt feeding without using interrupt tasks		If an interrupt input occurs, the motor moves the amount specified by the pulses, decelerates, and stops.	IFEED(892) (INTERRUPT FEEDING)	Refer to 8-4 <i>Implementing Interrupt Feeding</i>

● Outputting to the Auxiliary Area Using the OUT Instruction

The OUT instruction is used in the ladder program to write signals received from the CW limit sensor and CCW limit sensor connected to normal inputs to the Auxiliary Area bits.

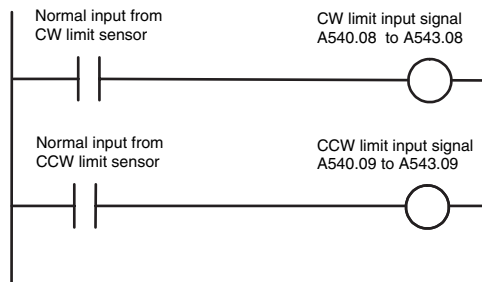

Bits Written in the Auxiliary Area

Auxiliary Area bit		Name	Function
Word	Bit		
A540	08	Pulse Output 0 CW Limit Input Signal	Signals received from external sensors connected to normal inputs must be written to the Auxiliary Area bits in the user program.
	09	Pulse Output 0 CCW Limit Input Signal	
A541	08	Pulse Output 1 CW Limit Input Signal	
	09	Pulse Output 1 CCW Limit Input Signal	
A542	08	Pulse Output 2 CW Limit Input Signal	
	09	Pulse Output 2 CCW Limit Input Signal	
A543	08	Pulse Output 3 CW Limit Input Signal	
	09	Pulse Output 3 CCW Limit Input Signal	

● Resetting the Pulse Output PV

Each cycle during overseeing processing, the pulse output PVs are reset if ON transitions are detected in the Reset Bits. The PVs are not cleared, however, if pulses are being output.

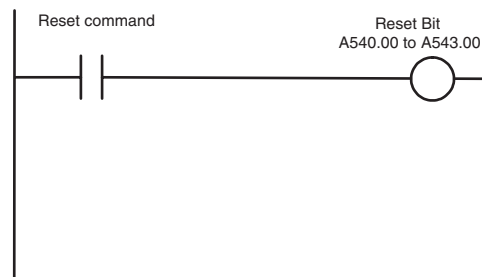

Auxiliary Area Bits

Auxiliary Area bit		Name	Function
Word	Bit		
A540	00	Pulse Output 0 Reset Bit	The pulse output PV will be cleared when one of these bits is turned ON.
A541	00	Pulse Output 1 Reset Bit	
A542	00	Pulse Output 2 Reset Bit	
A543	00	Pulse Output 3 Reset Bit	



Precautions for Safe Use

When using the BIT COUNTER (BCNT(067)), BLOCK SET (BSET(071)), and BLOCK TRANSFER (XFER(070)) in the ladder program, do not specify more than 99 words for each instruction. If more than 99 words must be used, use more than one instruction. Pulse output is not possible during execution of these instructions. If more than 99 words are specified for one of them, pulse output will not be predictable and may stop momentarily.

Transferring 120 Words of Data Started at D0 to Words Starting at D1000

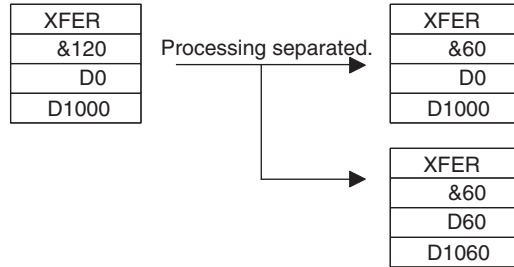

8-2 Position Control

This section describes how to use pulse outputs with the PLS2(887) instruction.

8-2-1 Position Control Configuration

If the target frequency, starting frequency, acceleration and deceleration rates, and direction are set beforehand, trapezoidal and S-curve position control will be performed according to the following time charts.

The target frequency is set in an operand of the PLS2 instruction.

Whether to use trapezoidal or S-curve acceleration/deceleration is set in the PLC Setup.

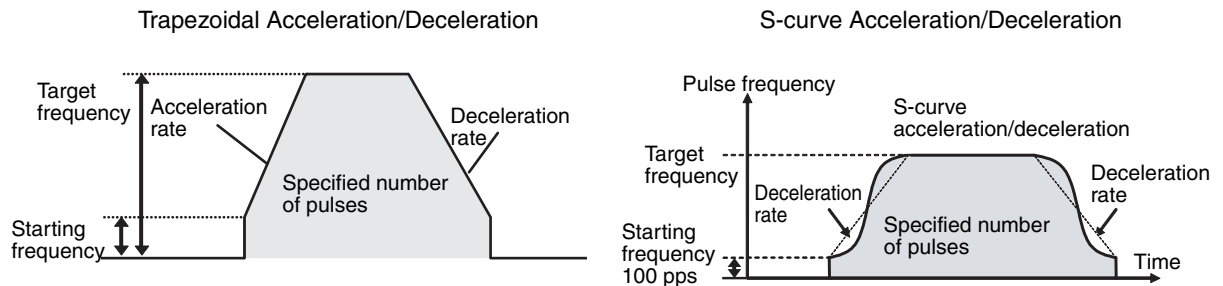

Target frequency	1 pps to 100 kpps (in increments of 1 pps)
Starting frequency	0 pps to 100 kpps (in increments of 1 pps)*
Acceleration rate	Set in increments of 1 pps from 1 to 65,535 pps (every 4 ms).
Deceleration rate	Set in increments of 1 pps from 1 to 65,535 pps (every 4 ms).
Direction specification	Set to CW or CCW.
Specified number of pulses	Relative coordinates: 0000 0000 to 7FFF FFFF hex (Accelerating or decelerating in either direction: 2,147,483,647) Absolute coordinates: 8000 0000 to 7FFF FFFF hex (-2,147,483,648 to 2,147,483,647)

* If S-curve acceleration/deceleration is specified, the starting frequency will be 100 pps.

Specify with the Acceleration/Deceleration Curve Specifications in the PLC Setup.

The screenshot shows a dialog box titled 'Pulse Output and Origin Search Detailed Settings'. It has a table with columns for 'Item', 'Pulse Output 0', 'Pulse Output 1', and 'Pulse Output 2'. The 'Speed Curve' setting is highlighted, and an arrow points from the text 'Specify with the Acceleration/Deceleration Curve Specifications in the PLC Setup.' to it. Other settings include 'Limit Input Signal Operation', 'Search/Return Initial Speed (pps)', 'Origin Search Setting', 'Search Direction', 'Origin Detected after Prox. Input', 'Operation Mode', 'Proximity Input Signal Type', 'Proximity Speed (pps)', 'Correction Value', 'Acceleration Rate', 'Deceleration Rate', 'Positioning Monitor Time (ms)', 'Origin Return', 'Target Speed (pps)', and 'Deceleration Rate'. At the bottom, there are buttons for 'Copy Pulse Output Settings', 'Copy', 'Defaults', 'Help', 'OK', and 'Cancel'. A note at the bottom left states 'Default settings are indicated by asterisks.' and there is a section for 'Internal Pulse Control Cycle' with radio buttons for '*4ms' and '1ms'.

● Positioning with S-curve Acceleration/Deceleration

With the S-curve acceleration/deceleration positioning, shock and vibration can be controlled by reducing the initial acceleration rate in comparison with a trapezoidal acceleration/deceleration rate.

This can be selected when there is some leeway in the maximum allowable speed.



Additional Information

- The same type of S-curve acceleration/deceleration can be used for ACC(888) as well.
- The curve for S-curve acceleration/deceleration is formed by applying a tertiary function to the straight line of the set acceleration/deceleration rates (a tertiary polynomial approximation). The curve parameters cannot be changed. The maximum acceleration will be 1.5 times that of trapezoidal acceleration/deceleration for the same acceleration/deceleration rate.



Precautions for Correct Use

- If the starting frequency is set to less than 100 pps, it will automatically be increased to 100 pps.

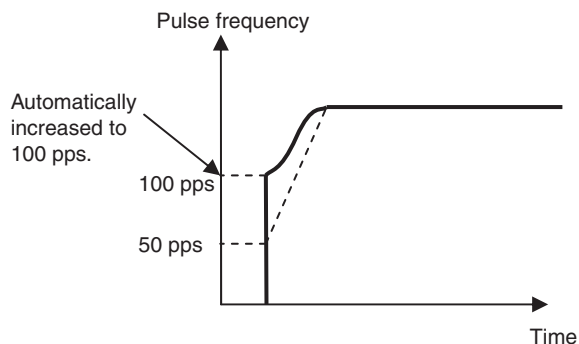

- S-curve acceleration/deceleration will not be performed if the target frequency is less than 100 pps.

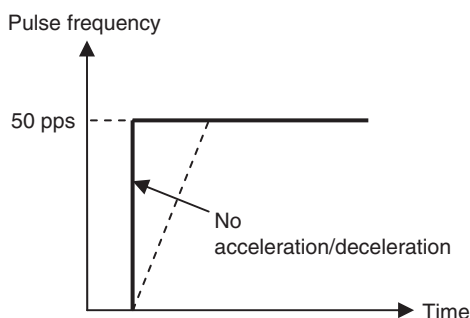

8-2-2 Relative Positioning and Absolute Positioning

● Selecting Relative or Absolute Coordinates

The coordinate system (absolute or relative) of the pulse output PV is selected automatically, as follows:

- When the origin is undefined, the system operates in relative coordinates.

- When the origin has been defined, the system operates using absolute coordinates.

Conditions	Origin has been defined by an origin search	Origin has been defined by executing the INI(880) instruction to change the PV	Origin is undefined (Origin search has not been performed and PV has not been changed with the INI(880) instruction.)
Coordinate system of pulse output PV	Absolute coordinate system		Relative coordinate system

Refer to 8-5-1 *Origin Searches* for details on origin searches.

● Relationship between the Coordinate System and Pulse Specifications

The following table shows the pulse output operation for the four possible combinations of the coordinate systems (absolute or relative) and the pulse output (absolute or relative) specified when the PULS(886) or PLS2(887) instruction is executed.

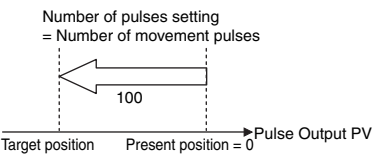
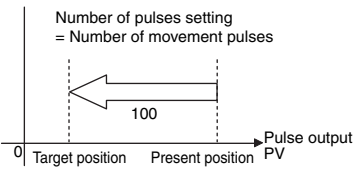
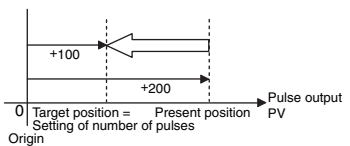
Pulse output specified in PULS(886) or PLS2(887)	Relative coordinate system	Absolute coordinate system
	Origin not defined (The No-origin Flag will be ON.)	Origin defined (The No-origin Flag will be OFF.)
Relative pulses specified	<p>Positions the system to another position relative to the present position.</p> <p>Number of movement pulses = Number of pulses setting</p> <p>The pulse output PV after instruction execution = Number of movement pulses = Number of pulses setting</p> <p>The pulse output PV is reset to 0 just before pulses are output. After that, the specified number of pulses is output.</p> <p>The following example shows the number of CCW pulses setting = 100 counterclockwise.</p>  <p>Number of pulses setting = Number of movement pulses</p> <p>Target position Present position = 0 Pulse Output PV</p> <p>Pulse output PV range: 8000 0000 to 7FFF FFFF hex Number of pulses setting range: 0000 0000 to 7FFF FFFF hex</p>	<p>The pulse output PV after instruction execution = PV + Number of movement pulses.</p> <p>The following example shows the number of pulses setting = 100 counterclockwise.</p>  <p>Number of pulses setting = Number of movement pulses</p> <p>0 Target position Present position PV</p> <p>Pulse output PV range: 8000 0000 to 7FFF FFFF hex Number of pulses setting range: 0000 0000 to 7FFF FFFF hex</p>
Absolute pulses specified	<p>Absolute pulses cannot be used when the origin location is undefined, i.e., when the system is operating with a relative coordinate system. An instruction execution error will occur.</p>	<p>Positions the system to an absolute position relative to the origin. The number of movement pulses and movement direction are calculated automatically from the present position (pulse output PV) and target position.</p> <p>The following example is for a number of pulses setting of +100.</p>  <p>0 Target position = Present position PV Setting of number of pulses Origin</p> <p>Number of movement pulses = Number of pulses setting – Pulse output PV when instruction is executed. The movement direction is determined automatically.</p> <p>Pulse output PV when instruction is executed = Number of pulses setting</p> <p>Pulse output PV range: 8000 0000 to 7FFF FFFF hex Number of pulses setting range: 8000 0000 to 7FFF FFFF hex</p>

**Precautions for Correct Use**

Absolute pulses cannot be specified when the origin is undefined. Specify them only when the origin has been defined by performing an origin search or by changing the PV with the INI(880) instruction.

**Additional Information**

The origin position is undefined in the following case. Define the origin position by performing an origin search again.

- When the pulse output reset flag is turned ON
- When the RUN or MONITOR mode is changed to the PROGRAM mode

8-2-3 Application Example**Specifications and Operation**

When the start input (CIO 2960.00) goes ON, this example program outputs 600,000 pulses from pulse output 1 to turn the motor.

In this example, trapezoidal position control is performed.

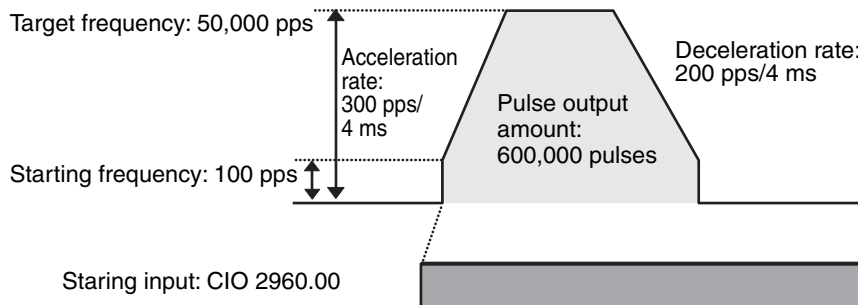
**Applicable Instructions**

PLS2(887) instruction

Preparations

● PLC Setup

There are no settings that need to be made in the PLC Setup.

● DM Area Settings

- Settings for PLS2(887) Instruction (D0 to D7)

Setting	Word	Data
Acceleration rate: 300 pps/4 ms	D0	#012C
Deceleration rate: 200 pps/4 ms	D1	#00C8
Target frequency: 50,000 pps	D2	#C350
	D3	#0000
Number of output pulses: 600,000 pulses	D4	#27C0
	D5	#0009
Starting frequency: 100 pps	D6	#0064
	D7	#0000

Ladder Program

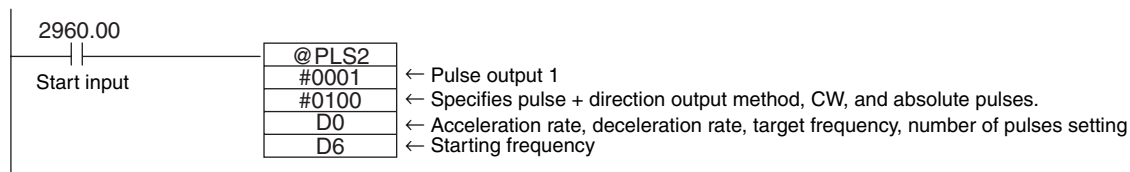

Additional Information

- Absolute pulses can be specified when the origin position has been defined.
- If a target frequency that cannot be reached has been set, the target frequency will be reduced automatically, i.e., triangular control will be performed.

8-3 Jogging

Jogging can be performed by using the SPED(885) (SPEED OUTPUT) and ACC(888) (ACCELERATION CONTROL) instructions. This section describes the procedure for jogging.

8-3-1 High-speed Jogging

Start pulse output with acceleration/deceleration using the ACC(888) instruction. In this case, the acceleration and deceleration rates must be the same. Set the target frequency of the ACC(888) instruction to 0 pps to stop the pulse output.

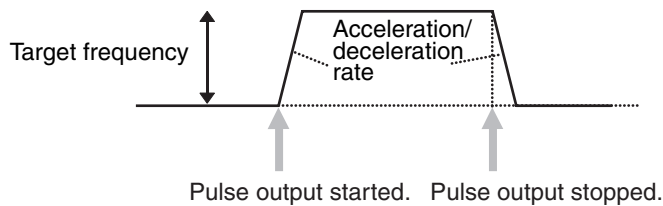

Target frequency	Starting pulse output: 1 pps to 100 kpps (in increments of 1 pps) Stopping pulse output: 0 pps
Acceleration/deceleration rate	Set in increments of 1 pps from 1 to 65,535 pps (every 4 ms).
Direction specification	Set to CW or CCW.
Mode specification	Set to continuous mode.



Additional Information

Jogging can also be performed with S-curve acceleration/deceleration.

8-3-2 Low-speed Jogging

Start pulse output without acceleration or deceleration using the SPED(885) instruction. Set the target frequency of the SPED(885) instruction to 0 pps to stop the pulse output.

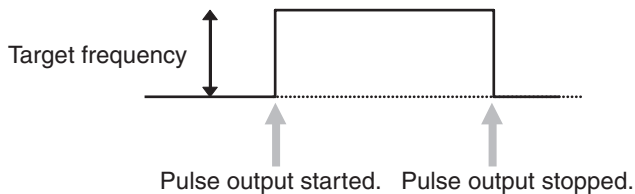

Target frequency	Starting pulse output: 1 pps to 100 kpps (in increments of 1 pps) Stopping pulse output: 0 pps
Direction specification	Set to CW or CCW.
Mode specification	Set to continuous mode.

8-3-3 Application Example

Specifications and Operation

The following example shows jogging without acceleration or deceleration executed using a SPED(885) instruction. It is used for low-speed jogging.

- Clockwise low-speed jogging will be executed from pulse output 1 while CIO 2960.00 is ON.
- Counterclockwise low-speed jogging will be executed from pulse output 1 while CIO 2960.01 is ON.

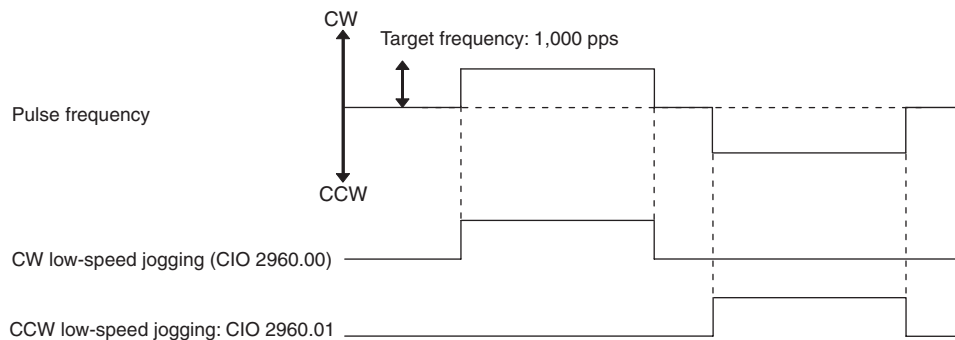

The example shows jogging with acceleration and deceleration executed using an ACC(888) instruction. It is used for high-speed jogging.

- Clockwise high-speed jogging will be executed from pulse output 1 while CIO 2960.04 is ON.
- Counterclockwise high-speed jogging will be executed from pulse output 1 while CIO 2960.05 is ON.

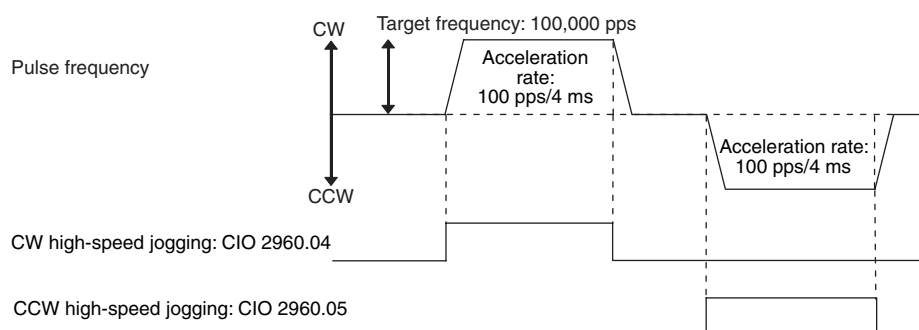

Preparations

● PLC Setup

There are no settings that need to be made in the PLC Setup.

● DM Area Settings

- Settings to Control Speed while Jogging (D0 to D1 and D10 to D15)

Setting	Word	Data
Target frequency (low speed): 1,000 pps	D0	#03E8
	D1	#0000
Acceleration rate: 100 pps/4 ms	D10	#0064
Target frequency (high speed): 100,000 pps	D11	#86A0
	D12	#0001
Acceleration/deceleration rate: 100 pps/4 ms (Not used.)	D13	#0064
Target frequency (stop): 0 pps	D14	#0000
	D15	#0000

Ladder Program

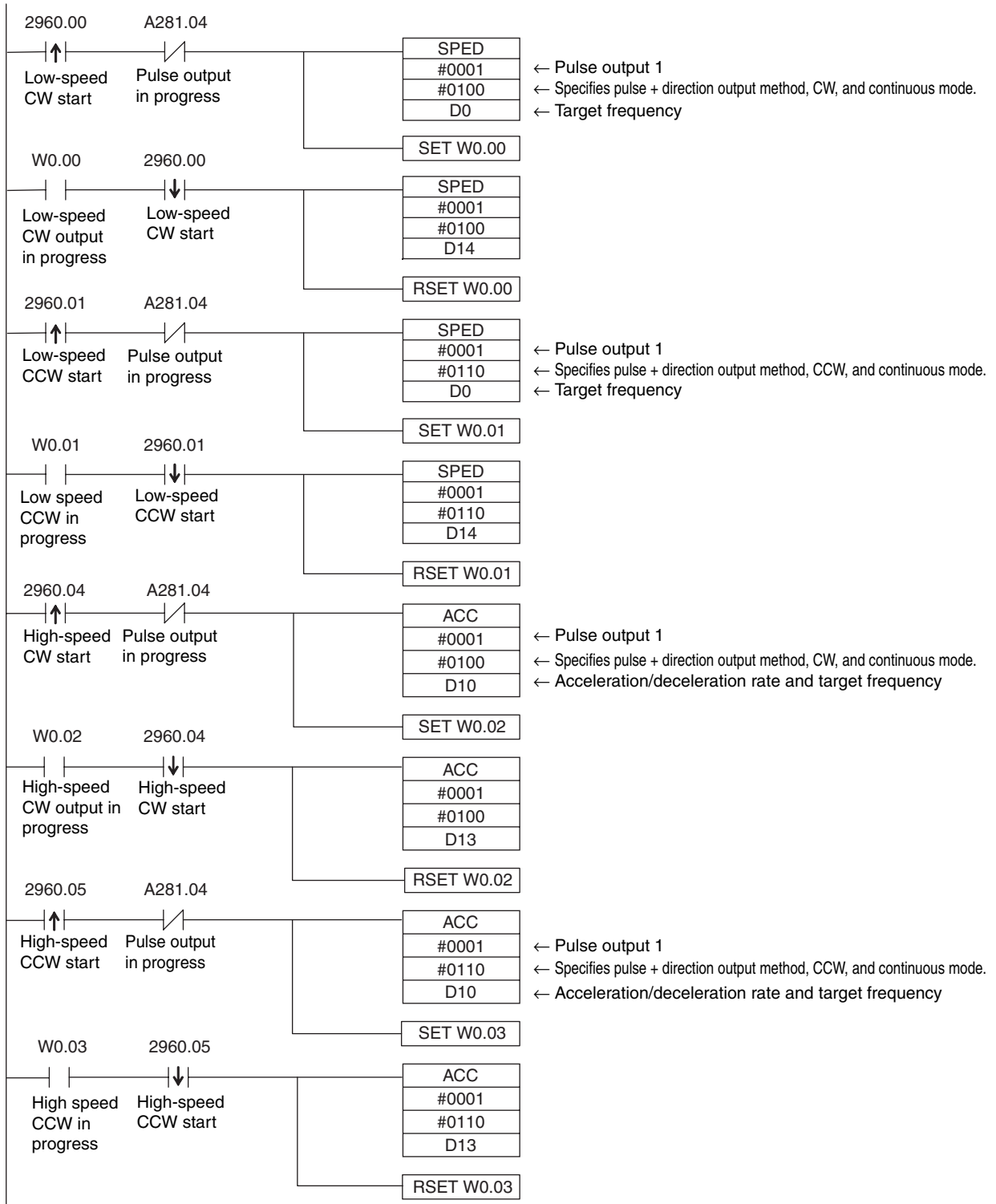

Additional Information

The PLS2(887) instruction can be used to set a starting frequency or separate acceleration and deceleration rates. But there are limitations on the operating range because the end point must be specified in the PLS2(887) instruction.

8-4 Implementing Interrupt Feeding

Interrupt feeding is useful for applications such as feeding wrapping material from a position where a marker was detected for a specified number of pulses (distance), and then stopping it.

8-4-1 Using the IFEED(892) (INTERRUPT FEEDING) Instruction

Interrupt feeding is performed with the IFEED(892) (INTERRUPT FEEDING) instruction. IFEED(892) controls interrupt feeding by combining the specified pulse output and interrupt input. An interrupt input is used as a trigger during speed control to switch to position control and then move a specified amount before decelerating to a stop. An interrupt task is not necessary, so no delays are caused by the interrupt startup time or the occurrence of other interrupts. The accuracy of feeding after an interrupt input occurs can therefore be improved.



Additional Information

Only specific pulse outputs and interrupt inputs can be used together.

If you want to pair any other pulse outputs and interrupt inputs, or if you want to change settings during pulse output, use the ACC(888) and PLS2(887) instructions together.

If the ACC(888) and PLS2(887) instructions are used, delays will occur for the interrupt startup time and possibly for other interrupts.

8-4-2 Setting Procedure

1

PLC Setup



2

Create ladder program.

- Select *Interrupt Input* in the Interrupt Input and Quick-response Input Detailed Settings Dialog Box that is accessed from the I/O Module Tab Page of the PLC Setup using the CX-Programmer.
- IN00, IN01, IN10, and IN11 can be used as interrupt inputs.
- Set whether to start the interrupt on OFF transitions or ON transitions in the input.
- Set pulse output ports 0 to 3, output mode, output direction, acceleration/deceleration rate, target frequency, and number of output pulses.
- Execute IFEED(892).

8-4-3 PLC Setup

Click the *I/O Module* Tab in the PLC Setup. Select *Interrupt Input* in the Interrupt Input and Quick-response Input Detailed Settings Dialog Box.

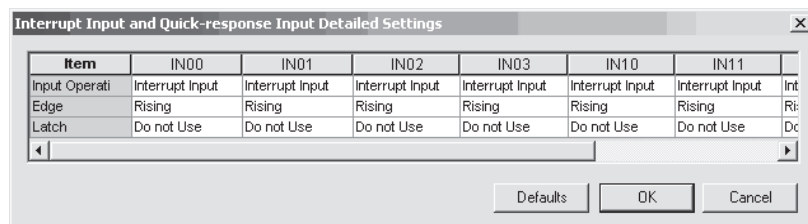
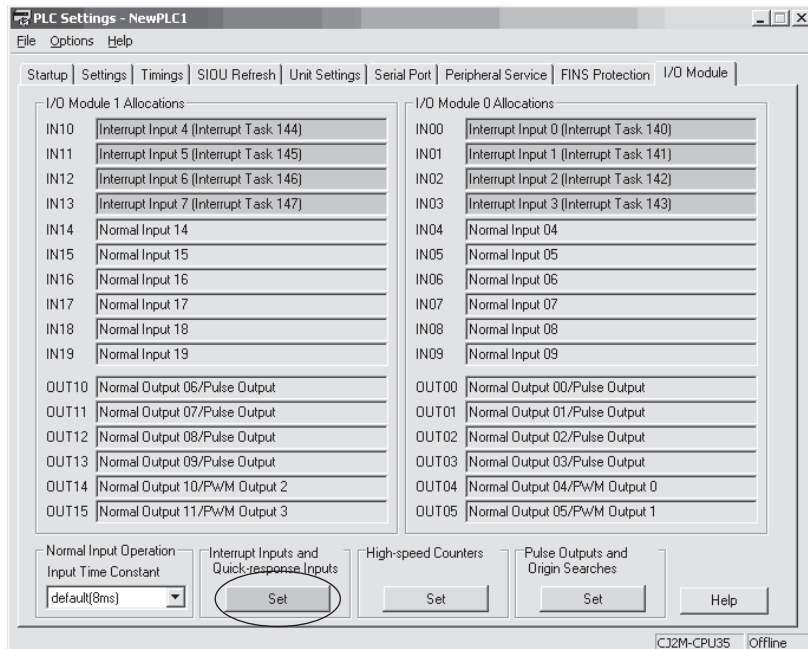

Interrupt Input and Quick-response Input Detailed Settings

Pulse I/O Module No.	Input Operation setting	Corresponding bit address
0 (on the right)	IN00	2960.00
	IN01	2960.01
1 (on the left)	IN10	2962.00
	IN11	2962.01

Item	Setting	
Interrupt inputs 0, 1, 4, and 5	Input Operation	Select <i>Interrupt</i> .
	Edge	Select one of the following. <ul style="list-style-type: none"> • Rising Edge (ON transition) • Falling Edge (OFF transition)

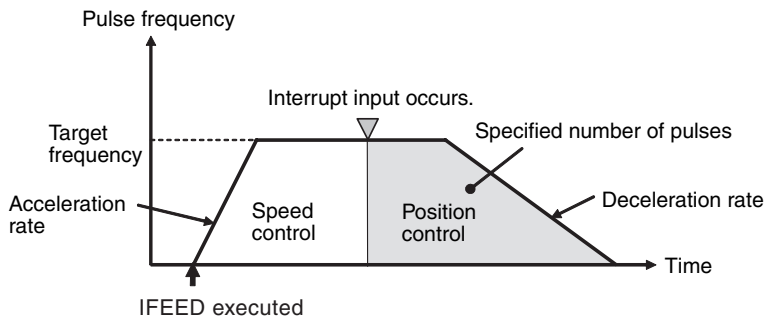

8-4-4 INTERRUPT FEEDING Instruction: IFEED(892)

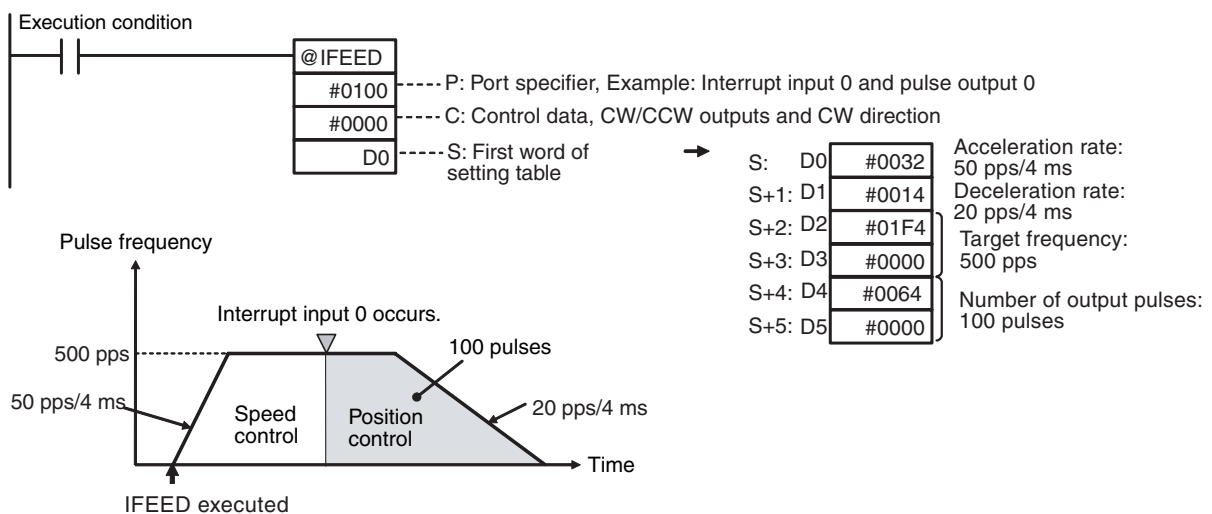

● Setting the Interrupt Input to Use

A specified combination of pulse output and interrupt input must be used for the IFEED(892) instruction. You cannot change the combinations. The pulse output and interrupt input are specified with operand P (port specifier) of the IFEED(892) instruction.

P	Pulse output	Interrupt input
#0000	Pulse output 0	Interrupt input 0
#0001	Pulse output 1	Interrupt input 1
#0002	Pulse output 2	Interrupt input 4
#0003	Pulse output 3	Interrupt input 5



Precautions for Correct Use

- Before executing the IFEED(892) instruction, use the MSKS(690) instruction to disable the specified interrupt if it is currently not masked. An instruction error will occur if the IFEED(892) instruction is executed when the interrupt is not masked.
- Interrupt inputs 0, 1, 4, and 5 are used with the IFEED(892) instruction. The terminals used for interrupt inputs 0 and 1 are also used for the origin and origin proximity inputs for pulse output 0. The terminals used for interrupt inputs 4 and 5 are also used for the origin and origin proximity inputs for pulse output 2. If the IFEED(892) instruction is used for pulse output 0 or 2, do not use the origin search function.

● Checking Status during Interrupt Feeding

The interrupt feeding status can be read from the following bits.

Name	Pulse output 0	Pulse output 1	Pulse output 2	Pulse output 3	Refresh timing
Interrupt Feeding In-progress Flag	A280.08	A281.08	A326.08	A327.08	<ul style="list-style-type: none"> • Cleared when power is turned ON. • Cleared when starting/stopping operation • Cleared during overseeing processing after completing interrupt feeding. • Turned ON when interrupt input is received after starting pulse output with IFEED(892) instruction
Interrupt Feeding Error Flag	A280.09	A281.09	A326.09	A327.09	<ul style="list-style-type: none"> • Cleared when power is turned ON. • Cleared when operation starts. • Cleared when IFEED(892) instruction processing is started. • Turned ON if an overflow or underflow occurs when an interrupt input is received, or if an overflow or underflow occurs while the specified number of pulses is being moved, after operation is started with the IFEED(892) instruction with the origin defined.

8-5 Defining the Origin

The CJ2 CPU Units have two methods that can be used to define the origin position.

- Origin searches

The ORG(889) instruction outputs pulses to turn the motor according to the pattern specified in the origin search parameters. As the motor turns, the origin search function defines the origin from the following three position input signals.

- Origin input signal
- Origin proximity input signal
- CW limit input signal and CCW limit input signal

- Changing the present value of the pulse output

When setting the current position as the origin, execute INI(880) to reset the pulse output PV to 0.

8-5-1 Origin Searches

When the ORG(889) instruction executes an origin search, it outputs pulses to actually move the motor and defines the origin position using the input signals that indicate the origin proximity and origin positions. The input signals that indicate the origin position can be received from the servomotor's built-in phase-Z signal or external sensors, such as photoelectric sensors, proximity sensors, or limit switches.

In the following example, the motor is started at a specified speed, accelerated to the origin search high speed, and run at that speed until the origin proximity position is detected. After the origin proximity input is detected, the motor is decelerated to the origin search low speed and run at that speed until the origin position is detected. The motor is stopped at the origin position.

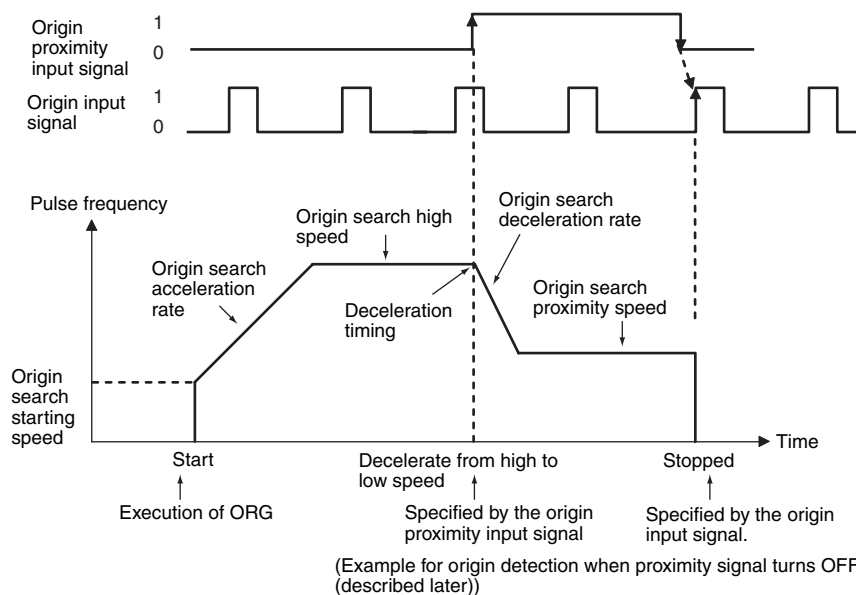

Additional Information

The motor can be moved even if the origin position has not been defined, but positioning operations will be limited as follows:

- Origin return: Cannot be used.
- Positioning with absolute pulse specification: Cannot be used.
- Positioning with relative pulse specification: Outputs the specified number of pulses after setting the present position to 0.

8-5-2 Setting Procedure

1

PLC Setup



2

Create ladder program.

- Set the origin search parameters in the Pulse Output and Origin Search Detailed Settings Dialog Box that is accessed from the I/O Module Tab Page of the PLC Setup using the CX-Programmer.
- Set pulse output ports 0 to 3.
- Output the status of the limit signal inputs and positioning completed signal to Auxiliary Area bits.
- Execute ORG(889). Specify an origin search.

8-5-3 PLC Setup

To perform an origin search or to use a limit input signal as an input to a function other than origin search, set the parameters on the Pulse Output and Origin Search Detailed Settings Dialog Box that is accessed from the I/O Module Tab Page in the PLC Setup.

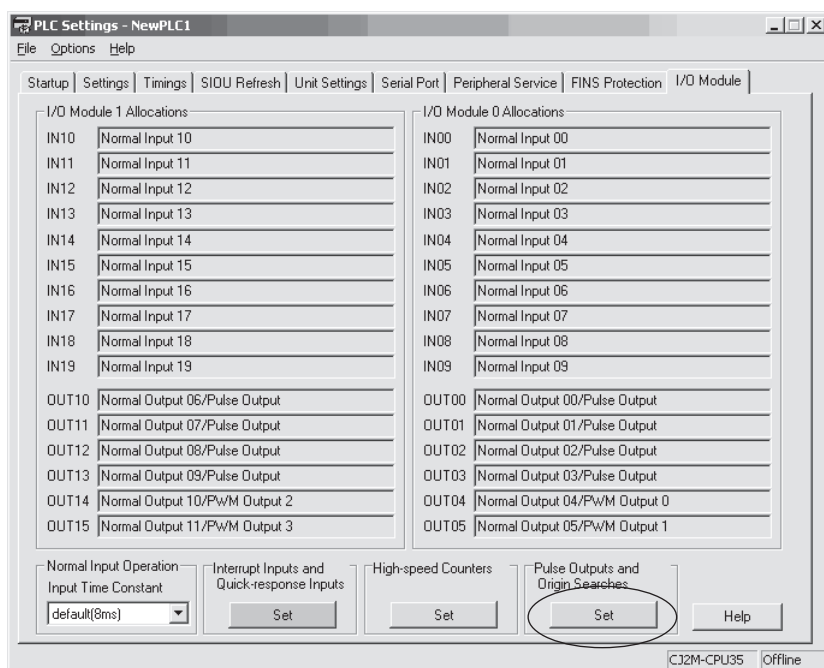

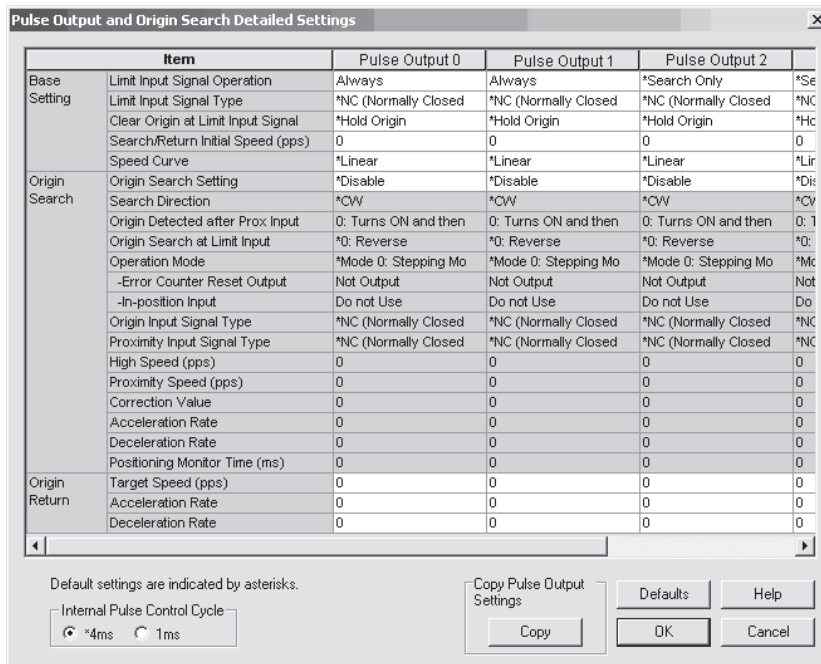

Pulse Output and Origin Search Detailed Settings

Item	Selection	Description	
Base Setting	Limit Input Signal Operation	Search Only	The CW/CCW limit input signal is used for origin searches only.
		Always	The CW/CCW limit input signal is used by functions other than origin search.
	Limit Input Signal Type	NC (Normally Closed)	Select when using NC contacts for the limit input signal.
		NO (Normally Open)	Select when using NO contacts for the limit input signal.
	Clear Origin at Limit Input Signal	Hold Origin	When a limit input signal is input, the pulse output is stopped and the previous status is held.
		Clear Origin	When a limit input signal is input, the pulse output is stopped and origin becomes undefined.
	Search/Return Initial Speed (pps)		Set the motor's starting speed when performing an origin search or origin return. Specify the speed in the number of pulses per second (pps). Setting range: 0 to 100 kpps The origin search will not be performed in these cases: Origin search high speed ≤ Origin search proximity speed. Origin search proximity speed ≤ Origin search initial speed.
	Speed Curve	Linear	Trapezoidal acceleration/deceleration is performed.
		S-curve	S-curve acceleration/deceleration is performed.

Item	Selection	Description	
Origin Search	Origin Search Setting	Select whether to use the origin search function.	
		Disable	The origin search function is not used.
		Enable	The origin search function is used.
	Search Direction		Set the direction for detecting the origin input signal. An origin search is performed so that the origin input signal's rising edge is detected when moving in the origin search direction.
		CW	Performs origin search in the clockwise direction.
		CCW	Performs origin search in the counterclockwise direction.
	Origin Detected after Prox Input		Set one of the following three methods to determine the pattern to use for the origin proximity input signal.
		0: Turns ON and then OFF	The origin input signal is accepted after the origin proximity input signal turns ON and then OFF.
		1: Turns ON	The origin input signal is accepted after the origin proximity input signal turns ON.
		2: Proximity Input Not Used	The origin input signal is accepted without using the origin proximity input signal. Only the origin search initial speed and origin search proximity speed are used for the origin search speeds.
	Origin Search at Limit Input		Select one of the following two modes for the origin search operation pattern.
		0: Reverse	The direction is reversed when the limit input signal is received while moving in the origin search direction.
		1: Stop with Error	An error occurs and operation is stopped if the limit input signal is received while moving in the origin search direction.
	Operation Mode		This parameter determines if a stepping motor or a Servomotor is used. Set whether to use positioning completed input signals when using a Servomotor.
		Mode 0: Stepping Motor	Error counter reset output: Not used. Positioning completed input: Not used.
		Mode 1: Servomotor	Error counter reset output: Used. Positioning completed input: Not used.
		Mode 2: Servomotor with INP	Error counter reset output: Used. Positioning completed input: Used.
	Origin Input Signal Type		Specifies the type of origin input signal (NC or NO).
		NC (Normally Closed)	Sets a normally closed origin input signal.
		NO (Normally Open)	Sets a normally open origin input signal.
	Proximity Input Signal Type		Specifies the type of origin proximity input signal (NC or NO).
		NC (Normally Closed)	Sets a normally closed origin proximity input signal.
		NO (Normally Open)	Sets a normally open origin proximity input signal.
High Speed (pps)		Sets the motor's target speed when the origin search is executed. Specify the speed in the number of pulses per second (pps). Setting range: 0 to 100 kpps The origin search will not be performed in these cases: Origin search high speed \leq Origin search proximity speed. Origin search proximity speed \leq Origin search initial speed.	

Item	Selection	Description
Origin Search	Proximity Speed (pps)	Sets the motor's speed after the origin proximity input signal is detected. Specify the speed in the number of pulses per second (pps). Setting range: 0 to 100 kpps The origin search will not be performed in these cases: Origin search high speed \leq Origin search proximity speed. Origin search proximity speed \leq Origin search initial speed.
	Correction Value	After the origin has been defined, the origin compensation can be set to compensate for a shift in the Proximity Sensor's ON position, for motor replacement, or for other changes. Setting range: -2,147,483,648 to 2,147,483,647 (pulses) Once the origin has been detected in an origin search, the number of pulses specified in the origin compensation is output, the present position is reset to 0, and the pulse output's No-origin Flag is turned OFF.
	Acceleration Rate	Setting range: 0 to 65,535 pps/ 4 ms Sets the motor's acceleration rate when the origin search is executed. Specify the amount to increase the speed (pps) per 4-ms interval.
	Deceleration Rate	Setting range: 0 to 65,535 pps/ 4 ms Sets the motor's deceleration rate when the origin search function is decelerating. Specify the amount to decrease the speed (pps) per 4-ms interval.
	Positioning Monitor Time (ms)	Setting range: 0 to 9,999 ms* When the operation mode is set to mode 2, this setting specifies how long to wait (in ms) for the positioning completed signal after the positioning operation has been completed, i.e., the pulse output has been completed. A Positioning Timeout Error (error code 0300) will occur if the motor drive's positioning completed signal does not turn ON within the specified time.
Origin Return	Target Speed (pps)	Setting range: 1 to 100 kpps Sets the motor's target speed when the origin return is executed. Specify the speed in the number of pulses per second (pps).
	Acceleration Rate	Setting range: 0 to 65,535 pps/ 4 ms Sets the motor's acceleration rate when the origin return operation starts. Specify the amount to increase the speed per 4-ms interval in 1-pps increments.
	Deceleration Rate	Setting range: 0 to 65,535 pps/ 4 ms Sets the motor's deceleration rate when the origin return function is decelerating. Specify the amount to decrease the speed per 4-ms interval in 1-pps increments.

* The actual monitoring time will be the Positioning Monitor Time rounded up to the nearest 10-ms increment + 10 ms max. If the Positioning Monitor Time is set to 0, the function will be disabled and the Unit will continue waiting for the positioning completed signal to come ON. (A Positioning Timeout Error will not occur.)

Note The power supply must be restarted after the PLC Setup is transferred in order to enable the settings for using the origin search.

Changing Parameters during Operation

Origin search and origin return settings can be changed during operation by executing the INI(880) instruction.



Precautions for Correct Use

Values in the PLC Setup will not change. If the power is cycled, the values in the PLC Setup will be applied.

● INI(880) Instruction

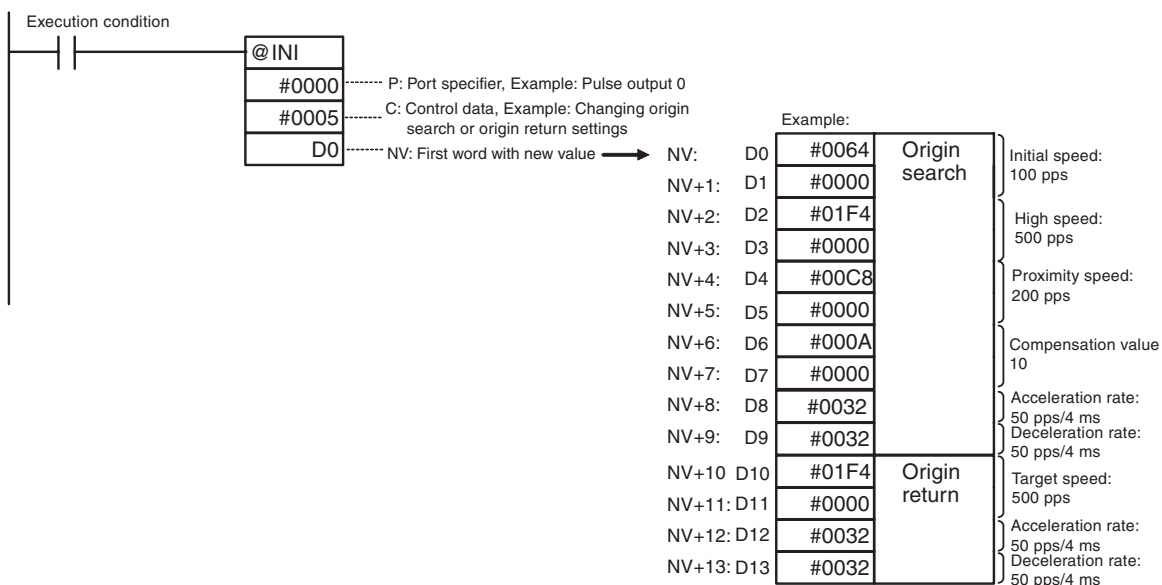

The following table shows whether a parameter can be changed in comparison with the PLC Setup.

Can be changed: Yes, Cannot be changed: No

Origin Search/Return Initial Speed Parameters		Pulse Output and Origin Search Detailed Settings Dialog Box in PLC Setup (enabled when power is turned ON)	Changing origin search/return settings with INI(880) instruction (can be changed during operation)
Base Setting	Limit Input Signal Operation	Yes	No
	Limit Input Signal Type		
	Clear Origin at Limit Input Signal		
	Search/Return Initial Speed (pps)		Yes (NV, NV+1)
	Speed Curve		No
Origin Search	Origin Search Setting		No
	Search Direction		
	Origin Detected after Prox Input		
	Origin Search at Limit Input		
	Operation Mode		
	Origin Input Signal Type		
	Proximity Input Signal Type		
	High Speed (pps)		Yes (NV+2, NV+3)
	Proximity Speed (pps)		Yes (NV+4, NV+5)
	Correction Value		Yes (NV+6, NV+7)
Acceleration Rate	Yes (NV+8)		
Deceleration Rate	Yes (NV+9)		
Positioning Monitor Time (ms)	No		
Origin Return	Target Speed (pps)	Yes (NV+10, NV+11)	
	Acceleration Rate	Yes (NV+12)	
	Deceleration Rate	Yes (NV+13)	



Precautions for Correct Use

When changing the parameters with the INI(880) instruction, an instruction error will occur if the new values are out of range. If any of the parameters specified with the instructions is out of range, none of the new parameters will be used, and the origin search operation will use the values in the PLC Setup.

8-5-4 Origin Search Instructions

ORIGIN SEARCH (ORG(889)) Instruction

Execute the ORG(889) instruction in the ladder program to perform an origin search with the specified parameters.

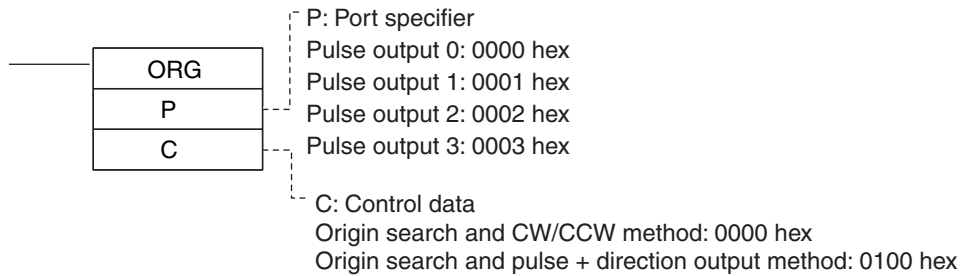

Precautions for Correct Use

Limit Sensor Application

Create a program that can detect the limit sensor when performing an origin search.

The OUT instruction is used in the ladder program to write signals received from the CW limit sensor and CCW limit sensor connected to normal inputs to the Auxiliary Area bits.

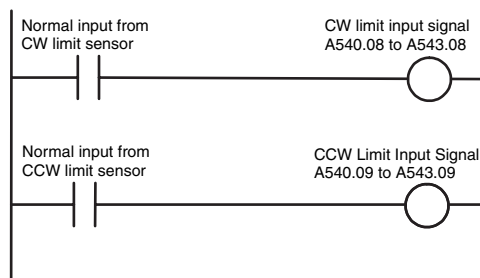

Bits Written in the Auxiliary Area

Auxiliary Area bit		Name	
Word	Bit		
A540	08	Pulse Output 0 CW Limit Input Signal Flag	Signals received from external sensors connected to normal inputs must be written to the Auxiliary Area bits in the user program.
	09	Pulse Output 0 CCW Limit Input Signal Flag	
A541	08	Pulse Output 1 CW Limit Input Signal Flag	
	09	Pulse Output 1 CCW Limit Input Signal Flag	
A542	08	Pulse Output 2 CW Limit Input Signal Flag	
	09	Pulse Output 2 CCW Limit Input Signal Flag	
A543	08	Pulse Output 3 CW Limit Input Signal Flag	
	09	Pulse Output 3 CCW Limit Input Signal Flag	

8-5-5 Origin Search Operations

Operation Mode Settings and Operation

The operation mode parameter specifies the I/O signals that are used in the origin search.

Operation Mode		Operation mode 0	Operation mode 1	Operation mode 2
Applicable Servo Drive		Stepping motor driver*1	Servo Drive	
		Two sensors, an origin proximity sensor and an origin sensor*2 are used to execute an origin search.	An origin proximity sensor and the phase-Z signal from a Servo Drive are used to execute an origin search.	
Operation		<ul style="list-style-type: none"> • Movement is decelerated when the origin proximity input is received and the search is completed on the origin input. • If the origin signal is received while decelerating for the proximity input, and origin signal error will occur and movement will decelerate to a stop. (error code 2002) 	<ul style="list-style-type: none"> • After decelerating for the origin proximity input, movement stops on the phase-Z input from the Servo Drive. Here, the error counter reset output is output to the Servo Drive to complete the search. • Phase-Z inputs are ignored during deceleration for the proximity input. 	<ul style="list-style-type: none"> • After decelerating for the origin proximity input, movement stops on the phase-Z input from the Servo Drive. Here, the error counter reset output is output to the Servo Drive and the search is completed when the positioning completed input is received from the Servo Drive. • Phase-Z inputs are ignored during deceleration for the proximity input.
I/O signals	Origin proximity input	Connect to a position detection sensor (e.g., photoelectric or proximity sensor).		
	Origin input	Connect to a position detection sensor (e.g., photoelectric or proximity sensor).	Connect to the phase-Z output signal from the Servo Drive.	
	Error counter reset output	Not used.	Connect to the error counter reset input of the Servo Drive.	
	Positioning completed input	Not used.	Not used.	Connect to the positioning completed signal output from the Servo Drive.

*1 There are stepping motor drives that are equipped with a positioning completed signal like a Servo Drive. Operation modes 1 and 2 can be used with these stepping motor drives.

*2 If *not using the proximity input* is set, only the origin input signal is used to perform the origin search.

● Operation Mode 0

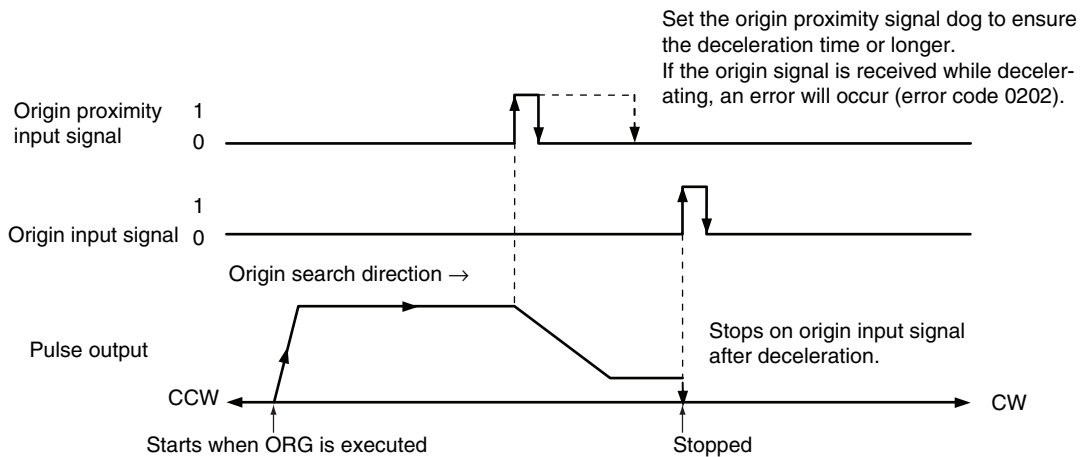

● Operation Mode 1

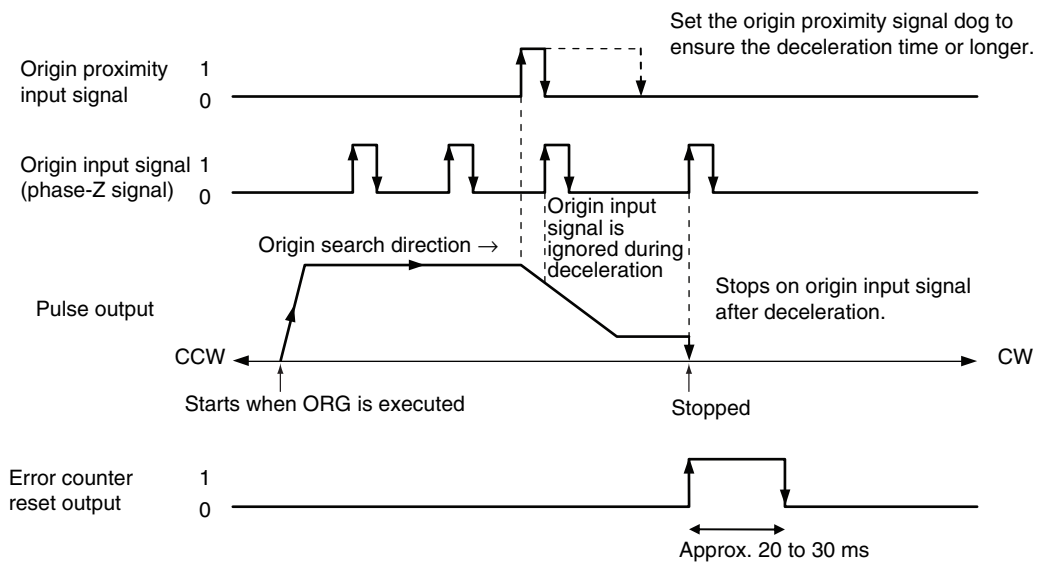

● Operation Mode 2

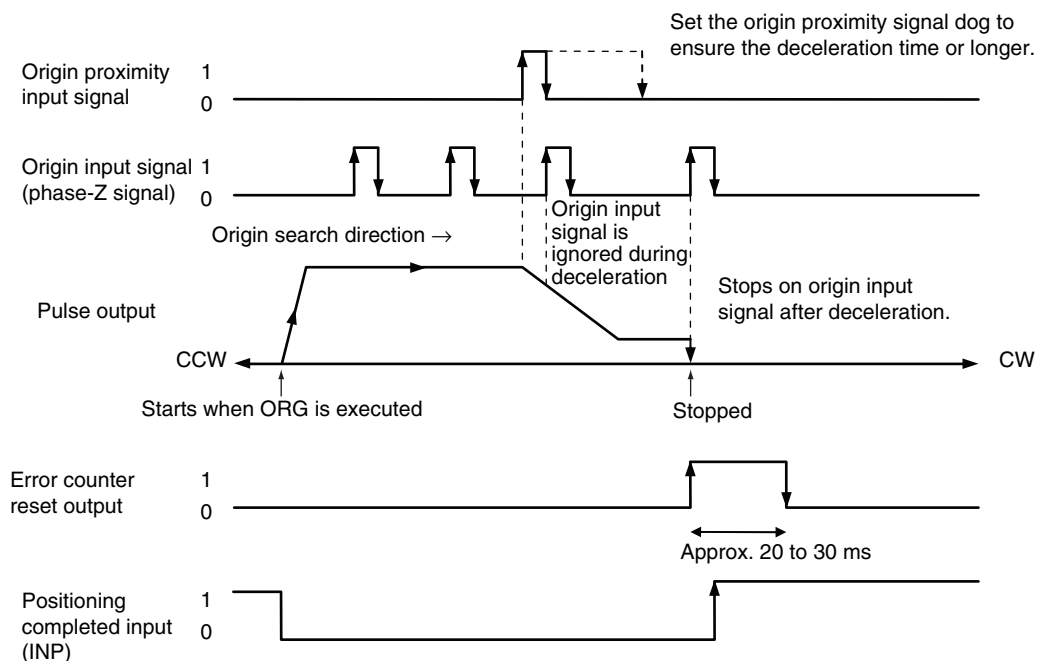

Origin Detection Timing and Operation for Limit Inputs

● Origin Detection Timing

The position where the origin is detected will depend on the following settings.

0: After Proximity Input Turns OFF

The first origin input signal after the proximity input turns ON is considered the origin.

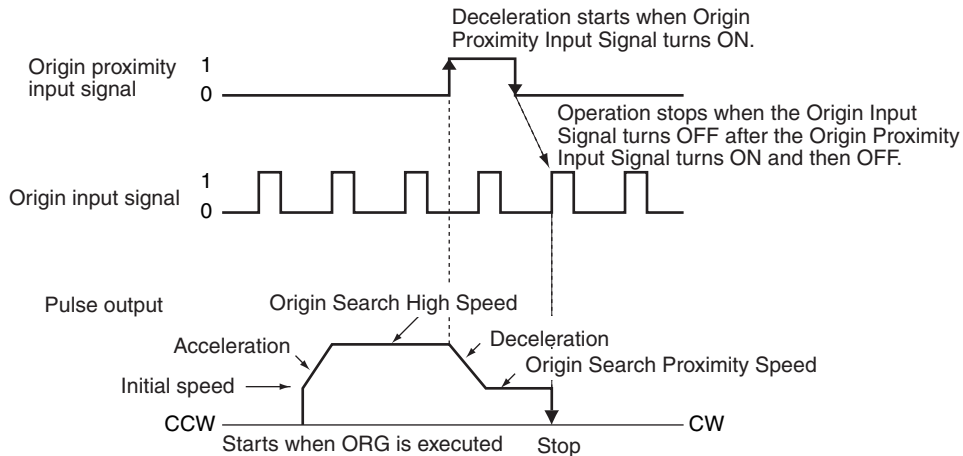

1: After Proximity Input Turns ON

The first origin input signal after the proximity input turns ON is considered the origin.

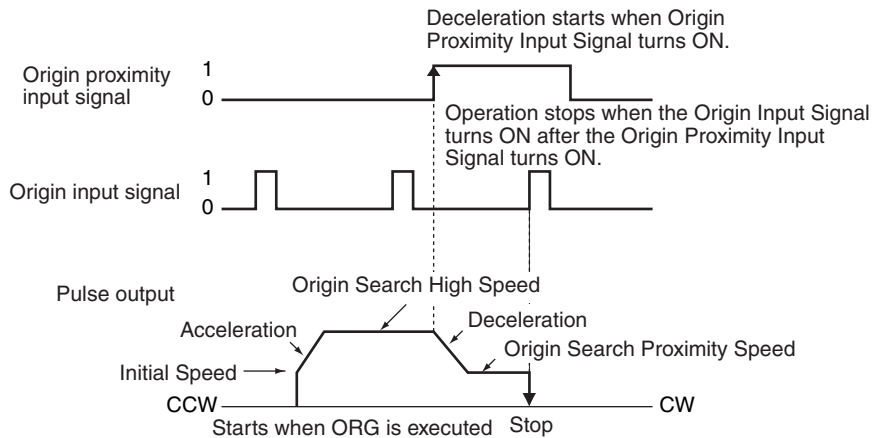

2: Proximity Input Not Used

The proximity input is not used and only the origin signal is used to perform the origin search.

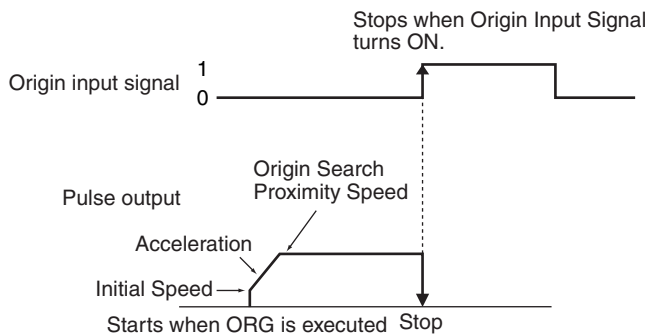

● **Operation for Limit Inputs**

The operation to perform for limit inputs that occur during origin searches can be set.

Method 0: Reverse

When the limit input signal is received, the motor stops without deceleration, reverses direction, and continues the origin search.

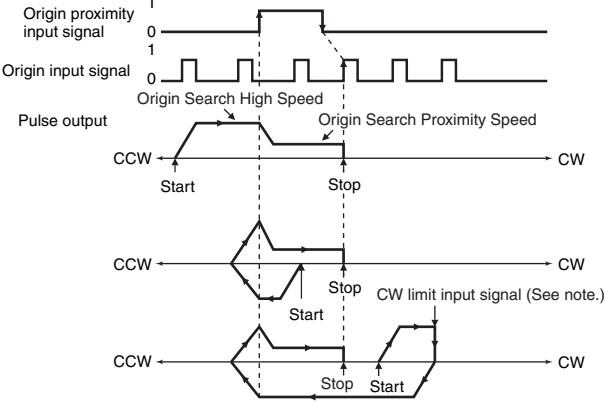
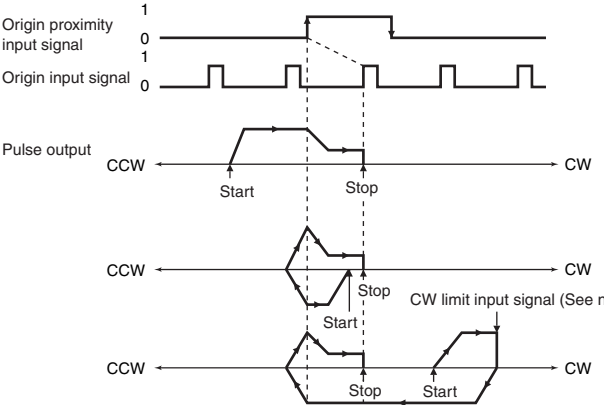
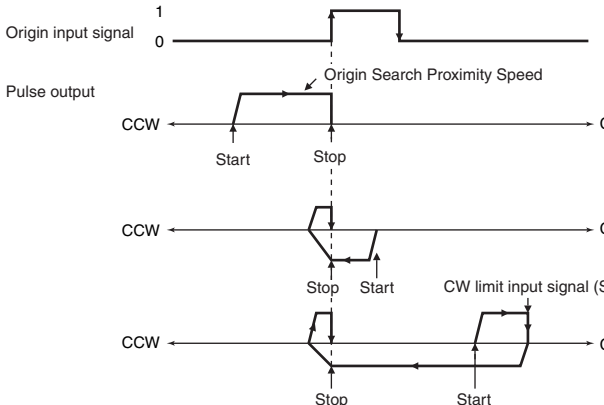
Origin Detected after Prox Input	Operation pattern
<p>Method 0: Turns ON and then OFF The origin input signal is accepted after the origin proximity input signal turns ON and then OFF.</p>	 <p>Note: When the Limit Input Signal is received, the motor stops without deceleration, reverses direction, and accelerates.</p>
<p>Method 1: Turns ON The origin input signal is accepted after the origin proximity input signal turns ON.</p>	 <p>Note: When the Limit Input Signal is received, the motor stops without deceleration, reverses direction, and accelerates.</p>
<p>Method 2: Proximity Input Not Used: The origin input signal is accepted without using the origin proximity input signal. Only the origin search proximity speed is used for the origin search speed.</p>	 <p>Note: When the Limit Input Signal is received, the motor stops without deceleration, reverses direction, and accelerates.</p>

Method 1: Stop with Error

When the limit input signal is received, the motor stops without deceleration and the origin search ends in an error.

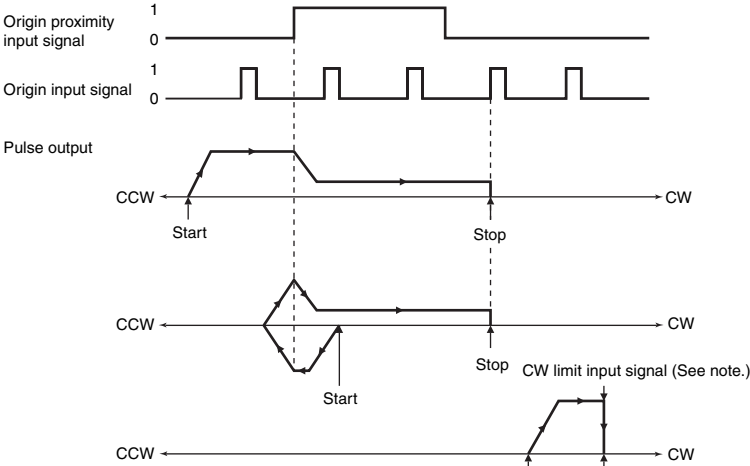
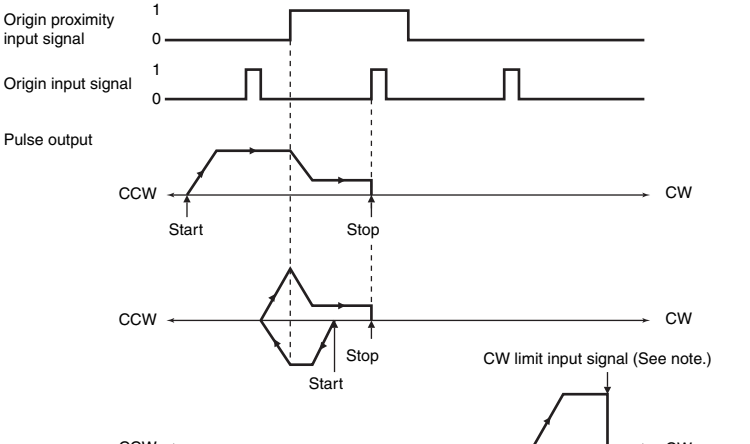
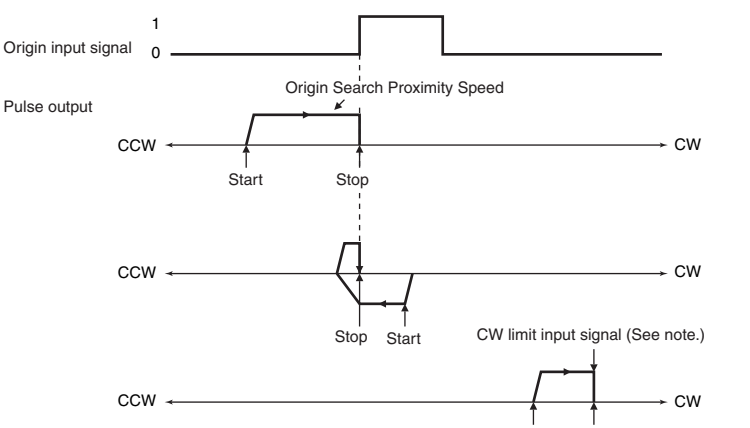
Origin Detection Method	Operation pattern
<p>Method 0: Turns ON and then OFF The origin input signal is accepted after the origin proximity input signal turns ON and then OFF.</p>	 <p>Note: When the Limit Input Signal is received, the motor stops without deceleration.</p>
<p>Method 1: Turns ON The origin input signal is accepted after the origin proximity input signal turns ON.</p>	 <p>Note: When the Limit Input Signal is received, the motor stops without deceleration.</p>
<p>Method 2: Proximity Input Not Used: The origin input signal is accepted without using the origin proximity input signal. Only the origin search proximity speed is used for the origin search speed.</p>	 <p>Note: When the Limit Input Signal is received, the motor stops without deceleration.</p>

8-5-6 Origin Return

An origin return operation moves the motor to the origin position from any other position.

The origin return operation is controlled by the ORG(889) instruction.

The origin return operation returns the motor to the origin by starting at the specified speed, accelerating to the target speed, moving at the target speed, and then decelerating to a stop at the origin position.

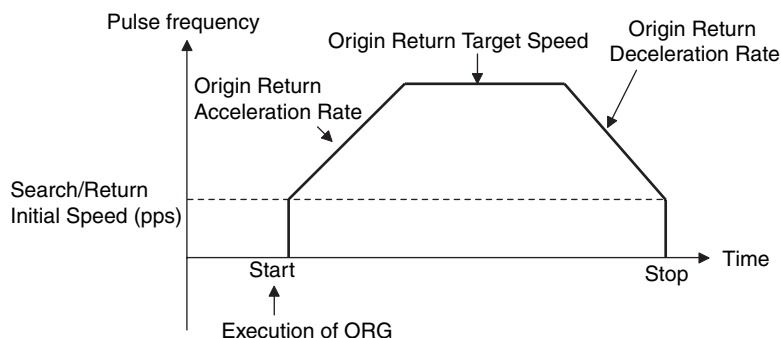

PLC Setup

Set the origin return parameters in the Pulse Output and Origin Search Detailed Settings Dialog Box that is accessed from the I/O Module Tab Page in the PLC Setup.

● Origin Return Parameters

	Name	Description	Setting range
Base Settings	Search/Return Initial Speed (pps)	Sets the motor's starting speed when an origin return is executed. Specify the speed in the number of pulses per second (pps).	0 to 100 kpps
Origin Return	Target Speed (pps)	Sets the motor's target speed when the origin return is executed. Specify the speed in the number of pulses per second (pps).	0 to 100 kpps
	Acceleration Rate	Sets the motor's acceleration rate when the origin return function is accelerating. Specify the amount to increase the speed per 4-ms interval in 1-pps increments.	0 to 65,535 (pps/4ms)
	Deceleration Rate	Sets the motor's deceleration rate when the origin return function is decelerating. Specify the amount to decrease the speed per 4-ms interval in 1-pps increments.	0 to 65,535 (pps/4ms)

ORIGIN SEARCH Instruction: ORG(889)

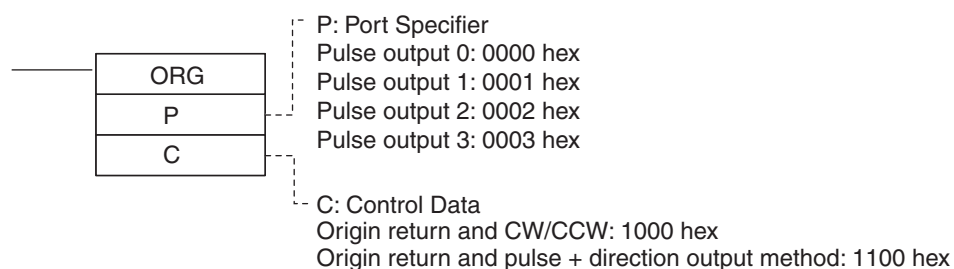

Note An instruction error will occur if the origin is not defined (i.e., when using a relative coordinate system) when the ORG(889) instruction is executed to perform an origin return operation.

8-5-7 Changing the PV of the Pulse Output

The present value of the pulse output can be changed by using the INI(880) instruction. To define the present value as the origin, set the pulse output PV to 0 using the INI(880) instruction.

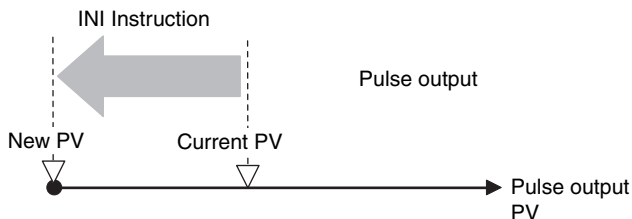

● **Example: Setting the Present Position as the Origin**

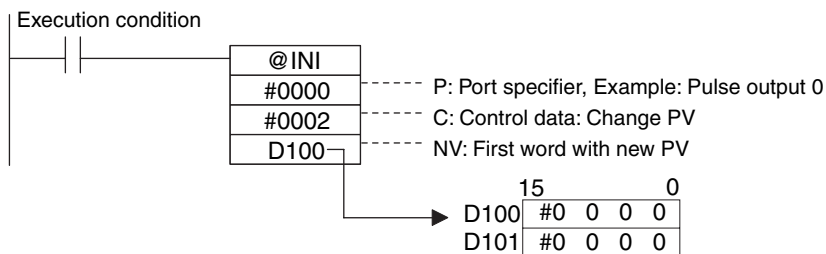

Operand		Setting	
P	Port specifier	#0000	Pulse output 0
		#0001	Pulse output 1
		#0002	Pulse output 2
		#0003	Pulse output 3
C	Control data	#0002	Changes the PV.
NV	First word with new PV	Store the new PV in NV and NV+1 (32 bits).	

8-5-8 Application Example

Operation

Connect a Servo Drive and execute an origin search based on the Servomotor's built-in encoder phase-Z signal and an origin proximity input signal.

Parameter Settings

- Operation Mode: 1
(Uses the Servomotor encoder's phase-Z signal as the origin input signal.)
- Origin Search at Limit Input: 0
(Sets reverse mode 0. Reverses direction when the limit input signal is input in the origin search direction.)
- Origin Detected after Prox Input: 0
(Reads the origin input signal after the origin input signal goes OFF→ON→OFF.)
- Search Direction: CW

System Configuration

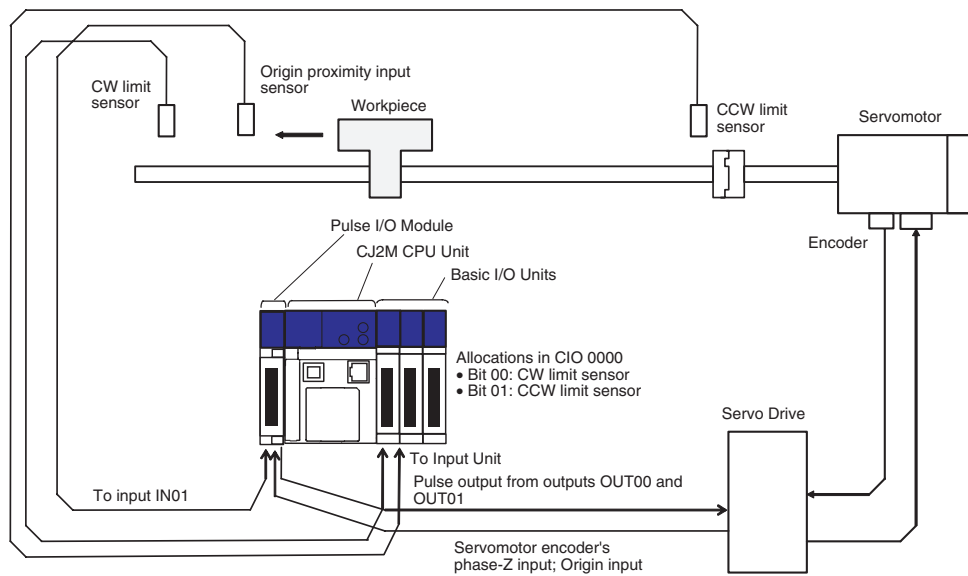

Applicable Instructions

ORG(889) instruction

I/O Allocations

● Inputs

I/O terminal	Bit	Name
IN00	CIO 2960.00	Origin Search 0 Origin Input Signal (Servomotor encoder's phase-Z signal)
IN01	CIO 2960.01	Origin Search 0 Origin Proximity Input Signal
–	A540.08	Pulse Output 0 CW Limit Input Signal Flag
–	A540.09	Pulse Output 0 CCW Limit Input Signal Flag
–	CIO 0000.00	CW Limit Sensor Input
–	CIO 0000.01	CCW Limit Sensor Input

● Outputs

I/O terminal	Bit	Name
OUT00	CIO 2961.00	Pulse Output 0 CW
OUT01	CIO 2961.01	Pulse Output 0 CCW

Operation

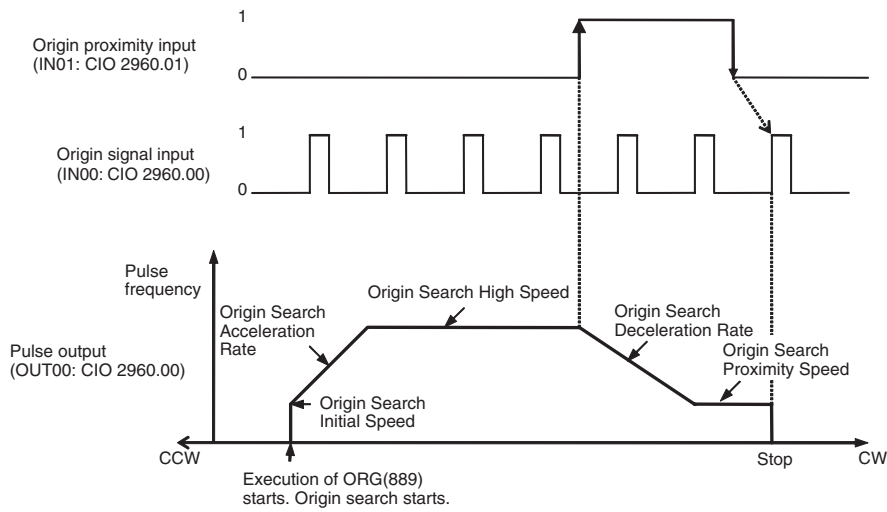

PLC Setup

PLC Setup	Setting (example)
Pulse Output 0 Origin Search Setting	Enable
Pulse Output 0 Operation Mode	1: Servo
Pulse Output 0 Error Counter Reset Output	Output
Pulse Output 0 In-position Input	Disable
Pulse Output 0 Origin Search at Limit Input	Reverse
Pulse Output 0 Origin Detected after Prox Input	Turns ON and then OFF
Pulse Output 0 Search Direction	CW
Pulse Output 0 Search/Return Initial Speed (pps)	100 pps
Pulse Output 0 High Speed (pps)	2000 pps
Pulse Output 0 Proximity Speed (pps)	1000 pps
Pulse Output 0 Correction Value	0000 hex
Pulse Output 0 Acceleration Rate	50 pps/4 ms
Pulse Output 0 Deceleration Rate	50 pps/4 ms
Pulse Output 0 Limit Input Signal Type	1: NO
Pulse Output 0 Proximity Input Signal Type	1: NO
Pulse Output 0 Origin Input Signal Type	1: NO

Ladder Program

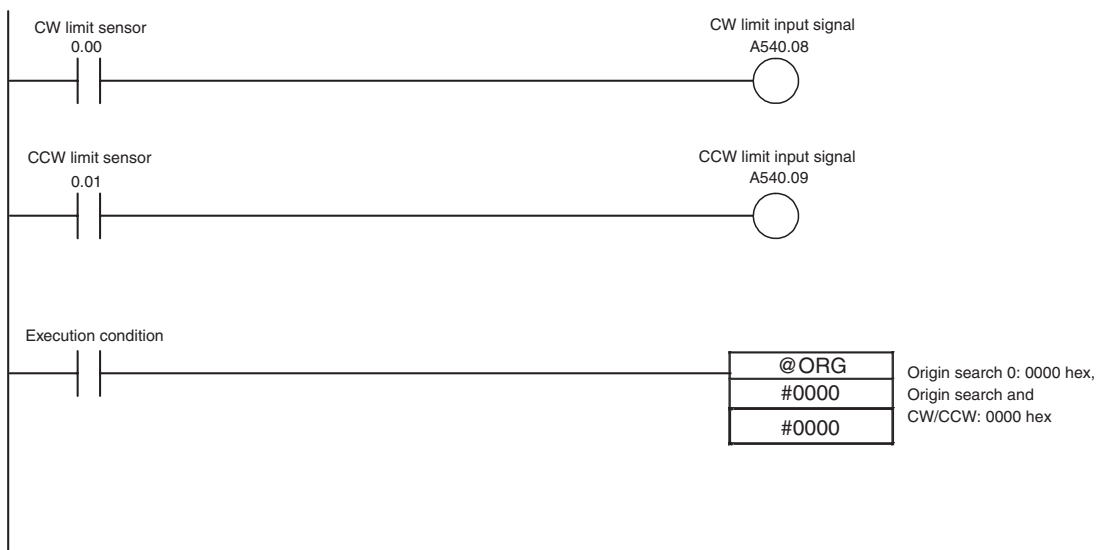

8-6 Reading the Pulse Output Present Value

The present value of a pulse output can be read in the following three ways.

- Reading the PV Refreshed at the I/O Refresh Timing → Read from the Auxiliary Area.
- Reading the PV during Program Execution → Read by executing the PRV(881) instruction.
- Reading the PV When an Interrupt Input Occurs → Use the software latch and read the value from the Auxiliary Area.

Reading the PV Refreshed at the I/O Refresh Timing

The PV that is stored in the following words can be read using the MOVL(498) instruction or other instructions.

Pulse I/O Module No.	Read PV	Auxiliary Area word
0 (on the right)	Pulse output 0	A277 (upper digits) and A276 (lower digits)
	Pulse output 1	A279 (upper digits) and A278 (lower digits)
1 (on the left)	Pulse output 2	A323 (upper digits) and A322 (lower digits)
	Pulse output 3	A325 (upper digits) and A324 (lower digits)

Reading the PV during Program Execution

● Reading the Pulse Output PV with a PRV(881) Instruction

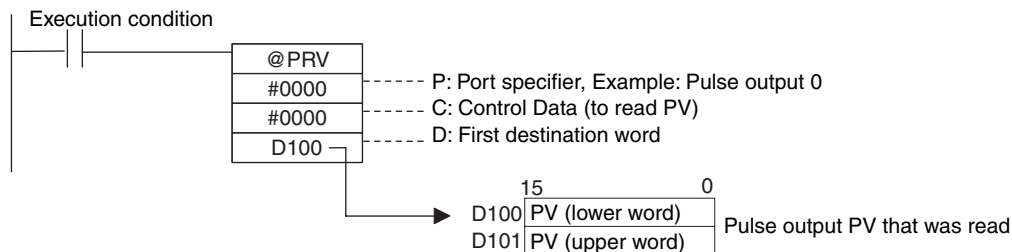

Reading the PV When an Interrupt Input Occurs

LPV(893) reads the pulse output PV each time an interrupt input occurs and stores the value in the Auxiliary Area. It reads the PV immediately before the interrupt input task is started. LPV(893) reads the PV more in realtime than starting an interrupt task and using the PRV(881) instruction to read the PV.

Refer to *Using Software Latches* on page 6-8.

8-7 Reading the Pulse Output Frequency

The frequency of a pulse output can be read in the following two ways.

- Reading the value at any time during program execution: Read by executing the PRV(881) instruction.
- Reading the value for each trace sampling cycle: Specify tracing the pulse frequency in the I/O Module AR Select Area on the Data Trace Configuration Tab Page of the CX-Programmer

Reading the Value When a Ladder Program Is Executed

● HIGH-SPEED COUNTER PV READ (PRV(881)) Instruction

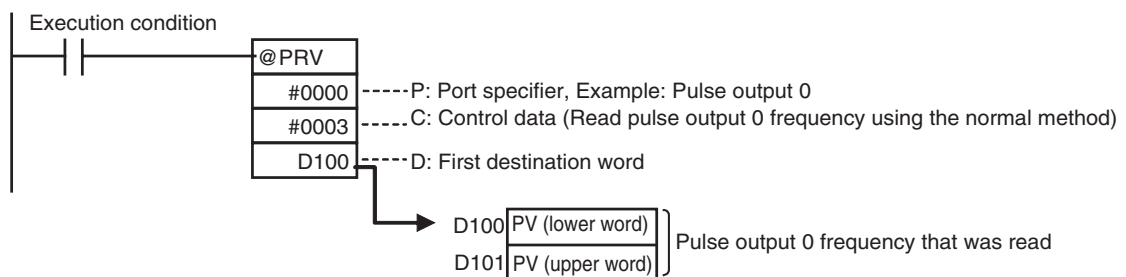

Reading the Pulse Output Frequency in Each Trace Sampling Cycle

● Specifying Pulse Frequency for Tracing with the Data Trace Function in the Easy Setup of the CX-Programmer

Select the pulse frequencies to be traced (pulse output n, where n = 0 to 3, in 1-Hz increments) in the I/O Module AR Select Area on the Data Trace Configuration Tab Page of the CX-Programmer. The frequency of the specified pulse output will be traced every trace sampling cycle.

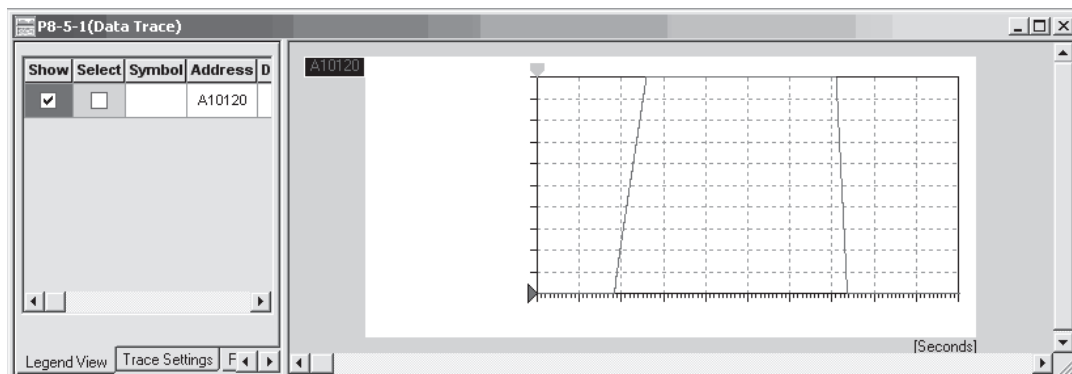

8-8 Related Auxiliary Area Bits

Related Auxiliary Area Bits

Name	Word/Bit	Function	Read/Write	Refresh timing
Pulse Output 0 PV	A276 to A277	Contain the number of pulses output from the corresponding pulse output port.	Read	<ul style="list-style-type: none"> Cleared when power is turned ON. Cleared when operation starts. Cleared when Pulse Output Reset Bit is turned ON. Cleared when pulse output is started (when the origin is not defined). Refreshed each cycle during overseeing process. Refreshed when INI(880) instruction is executed to change the PV. Refreshed when PRV(881) instruction is executed to read the PV or status.
Pulse Output 1 PV	A278 to A279	PV range: 8000 0000 to 7FFF FFFF hex (-2,147,483,648 to 2,147,483,647)		
Pulse Output 2 PV	A322 to A323	When pulses are being output in the CW direction, the PV is incremented by 1 for each pulse.		
Pulse Output 3 PV	A324 to A325	When pulses are being output in the CCW direction, the PV is decremented by 1 for each pulse. PV after overflow: 7FFF FFFF hex PV after underflow: 8000 0000 hex A276, A278, A322, and A324 contain the lower 4 digits. A277, A279, A323, and A325 contain the upper 4 digits.		
Pulse Output 0 Pulse Output Status Flag	A280.00	This flag will be ON when pulses are being output from pulse output 0 to 3 according to an ORG(889), ACC(888), PLS2(887), or IFEEED(892) instruction and the output frequency is being changed in steps (accelerating or decelerating).	Read	<ul style="list-style-type: none"> Cleared when power is turned ON. Cleared when operation is started or stopped. Refreshed each cycle (overseeing processing).
Pulse Output 1 Pulse Output Status Flag	A281.00			
Pulse Output 2 Pulse Output Status Flag	A326.00	OFF: Constant speed, ON: Accelerating/decelerating		
Pulse Output 3 Pulse Output Status Flag	A327.00			
Pulse Output 0 PV Overflow/Underflow	A280.01	This flag indicates when an overflow or underflow has occurred in the pulse output 0 PV. OFF: Normal, ON: Error	Read	<ul style="list-style-type: none"> Cleared when power is turned ON. Cleared when starting/stopping operation Cleared when the INI(880) instruction is executed to change the PV. Refreshed when underflow or overflow occurs.
Pulse Output 1 PV Overflow/Underflow	A281.01			
Pulse Output 2 PV Overflow/Underflow	A326.01			
Pulse Output 3 PV Overflow/Underflow	A327.01			

Name	Word/Bit	Function	Read/Write	Refresh timing
Pulse Output 0 Output Amount Set Flag	A280.02	This flag will be ON when the number of output pulses for pulse output 0 to 3 has been set with the PULS(886) instruction. OFF: Not set, ON: Set	Read	<ul style="list-style-type: none"> • Cleared when power is turned ON. • Cleared when operation is started or stopped. • Refreshed when PULS(886) instruction is executed. • Refreshed when pulse output is stopped.
Pulse Output 1 Output Amount Set Flag	A281.02			
Pulse Output 2 Output Amount Set Flag	A326.02			
Pulse Output 3 Output Amount Set Flag	A327.02			
Pulse Output 0 Output Completed Flag	A280.03	This flag will be ON when the number of output pulses set with the PULS(886), PLS2(887), or IFEEED(892) instruction has been output through pulse output 0 to 3. OFF: Output not completed, ON: Output completed	Read	<ul style="list-style-type: none"> • Cleared when power is turned ON. • Cleared when operation is started or stopped. • Refreshed when pulse output is started or stopped in Independent Mode.
Pulse Output 1 Output Completed Flag	A281.03			
Pulse Output 2 Output Completed Flag	A326.03			
Pulse Output 3 Output Completed Flag	A327.03			
Pulse Output 0 Output In-progress Flag	A280.04	This flag will be ON when pulses are being output from pulse output 0 to 3. OFF: Stopped, ON: Outputting	Read	<ul style="list-style-type: none"> • Cleared when power is turned ON. • Cleared when operation is started or stopped. • Refreshed when starting/stopping pulse output
Pulse Output 1 Output In-progress Flag	A281.04			
Pulse Output 2 Output In-progress Flag	A326.04			
Pulse Output 3 Output In-progress Flag	A327.04			
Pulse Output 0 No-origin Flag	A280.05	This flag will be ON when the origin has not been defined for pulse output 0 to 3 and goes OFF when the origin has been defined. OFF: Origin established, ON: Origin not established	Read	<ul style="list-style-type: none"> • Turned ON when power is turned ON. • Turned ON when starting operation. • Turned ON when the pulse output is reset. • Turned ON when an origin search is started. • Turned ON when a limit input is received and clearing is set. • Turned ON when an overflow or underflow occurs. • Turned OFF when an origin search is completed. • Turned OFF when INI(880) instruction is executed to change the PV.
Pulse Output 1 No-origin Flag	A281.05			
Pulse Output 2 No-origin Flag	A326.05			
Pulse Output 3 No-origin Flag	A327.05			

Name	Word/Bit	Function	Read/Write	Refresh timing
Pulse Output 0 At-origin Flag	A280.06	This flag will be ON when the pulse output 0 to 3 PV matches the origin (0).	Read	<ul style="list-style-type: none"> • Turned ON when power is turned ON. • Turned ON when stopped at the origin. • Turned OFF when the origin is left.
Pulse Output 1 At-origin Flag	A281.06	OFF: Not stopped at origin, ON: Stopped at origin		
Pulse Output 2 At-origin Flag	A326.06			
Pulse Output 3 At-origin Flag	A327.06			
Pulse Output 0 Output Stopped Error Flag	A280.07	This flag will be ON when an error has occurred while outputting pulses in the pulse output 0 to 3 origin search function.	Read	<ul style="list-style-type: none"> • Cleared when power is turned ON. • Cleared when an origin search is started. • Refreshed when a fatal pulse output error occurs during an origin search. • Refreshed when the limit input signal for pulse output is set to be always enabled in the PLC Setup and pulse output is stopped due to the limit input. • Cleared when both limit inputs are disabled and a fatal pulse output error code is stored.
Pulse Output 1 Output Stopped Error Flag	A281.07	The Pulse Output 0 to 3 Output Stop Error code will be written to A444.		
Pulse Output 2 Output Stopped Error Flag	A326.07	OFF: No error, ON: Stop error		
Pulse Output 3 Output Stopped Error Flag	A327.07			
Pulse Output 0 Interrupt Feeding In-progress Flag	A280.08	These flags are turned ON when an interrupt input is received after output from pulse outputs 0 to 3 is started with the IFEED(892) instruction.	Read	<ul style="list-style-type: none"> • Cleared when power is turned ON. • Cleared when operation is started or stopped. • Cleared during overseeing processing after completing interrupt feeding. • Turned ON when interrupt input is received after starting pulse output with IFEED(892) instruction
Pulse Output 1 Interrupt Feeding In-progress Flag	A281.08	OFF: Interrupt feeding not in progress. ON: Interrupt feeding in progress.		
Pulse Output 2 Interrupt Feeding In-progress Flag	A326.08			
Pulse Output 3 Interrupt Feeding In-progress Flag	A327.08			

Name	Word/Bit	Function	Read/Write	Refresh timing
Pulse Output 0 Interrupt Feeding Error Flag	A280.09	These flags will turn ON if an overflow or underflow occurs when an interrupt input is received, or when the specified number of pulses is moved, after output from pulse outputs 0 to 3 is started with the IFEEED(892) instruction. ON: No error. OFF: Overflow/underflow or specified number of pulses has been moved.	Read	<ul style="list-style-type: none"> • Cleared when power is turned ON. • Cleared when operation starts. • Cleared when IFEEED(892) instruction processing is started. • Turned ON if an overflow or underflow occurs when an interrupt input is received, or if an overflow or underflow occurs while the specified number of pulses is being moved, after operation is started with the IFEEED(892) instruction with the origin defined.
Pulse Output 1 Interrupt Feeding Error Flag	A281.09			
Pulse Output 2 Interrupt Feeding Error Flag	A326.09			
Pulse Output 3 Interrupt Feeding Error Flag	A327.09			
Pulse Output 0 Stop Error Code	A444	If a Pulse Output Stop Error occurs for pulse output 0 to 3, the error code is written to this word.	Read	<ul style="list-style-type: none"> • Cleared when power is turned ON. • Cleared when an origin search is started. • Refreshed when a fatal pulse output error occurs during an origin search. • Refreshed when the limit input signal for pulse output is set to be always enabled in the PLC Setup and pulse output is stopped due to the limit input. • Cleared when both limit inputs are disabled and a fatal pulse output error code is stored.
Pulse Output 1 Stop Error Code	A445			
Pulse Output 2 Stop Error Code	A438			
Pulse Output 3 Stop Error Code	A439			
Pulse Output 0 Reset Bit	A540.00	The PV of the pulse output (0 to 3) will be cleared when the corresponding bit is turned ON. A276, A278, A322, and A324 contain the lower 4 digits of the pulse output PV. A277, A279, A323, and A325 contain the upper 4 digits of the pulse output PV.	Read/Write	<ul style="list-style-type: none"> • Cleared when power is turned ON.
Pulse Output 1 Reset Bit	A541.00			
Pulse Output 2 Reset Bit	A542.00			
Pulse Output 3 Reset Bit	A543.00			

Name	Word/Bit	Function	Read/Write	Refresh timing
Pulse Output 0 CW Limit Input Signal	A540.08	This is the CW limit input signal for pulse output 0 to 3, which is used in the origin search. To use this signal, write the input from the actual sensor as an input condition in the ladder program and output the result to this flag.	Read/Write	<ul style="list-style-type: none"> Cleared when power is turned ON.
Pulse Output 1 CW Limit Input Signal	A541.08			
Pulse Output 2 CW Limit Input Signal	A542.08			
Pulse Output 3 CW Limit Input Signal	A543.08			
Pulse Output 0 CCW Limit Input Signal Flag	A540.09	This is the CCW limit input signal for pulse output 0 to 3, which is used in the origin search. To use this signal, write the input from the actual sensor as an input condition in the ladder program and output the result to this flag.	Read/Write	
Pulse Output 1 CCW Limit Input Signal Flag	A541.09			
Pulse Output 2 CCW Limit Input Signal Flag	A542.09			
Pulse Output 3 CCW Limit Input Signal Flag	A543.09			
Pulse Output 0 Frequency	A10120 and A10121	Contains the frequency of pulse output 0 to 3 when tracing pulse output 0 to 3 with data tracing. Valid only when the data tracing parameters are set.	---	<ul style="list-style-type: none"> Cleared when power is turned ON.
Pulse Output 1 Frequency	A10122 and A10123			
Pulse Output 2 Frequency	A10124 and A10125			
Pulse Output 3 Frequency	A10126 and A10127			

8-9 Application Example

8-9-1 Cutting Long Material Using Fixed Feeding

Specifications and Operation

● Overview

First jogging is used to position the material. Then fixed-distance feeding is repeated.

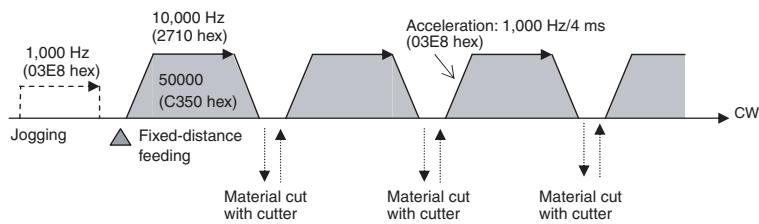

● System Configuration

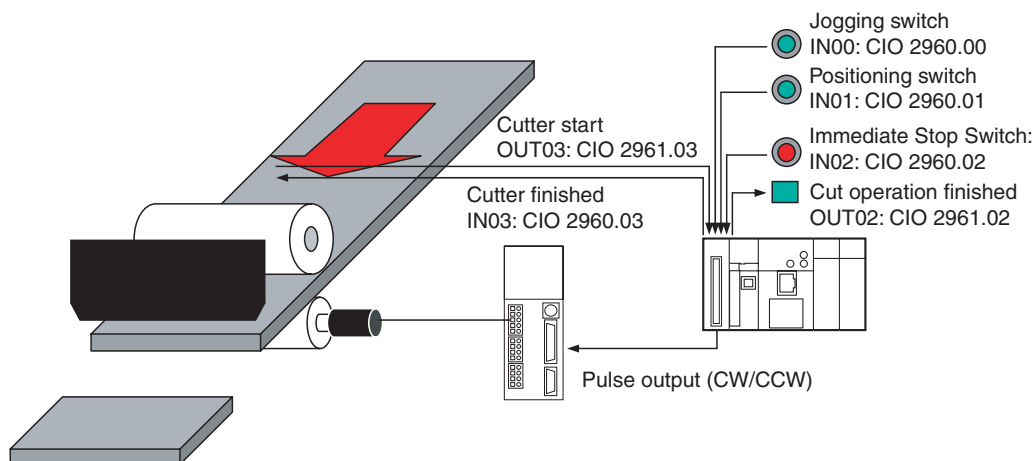

● Operation

- 1** The workpiece is set at the starting position using the jogging switch input (IN00: CIO 2960.00).
- 2** The workpiece is fed the specified distance (relative) using the positioning switch input (IN01: CIO 2960.01).
- 3** When feeding has been completed, the cutter is activated using the cutter start output (OUT03: CIO 2961.03).
- 4** Feeding is started again when the cutter finished input (IN03: CIO 2960.03) turns ON.
- 5** The feeding/cutting operation is repeated for the number of times specified for the counter (C0, 100 times).
- 6** When the operation has been completed, the Cut Operation Finished Output (OUT02: CIO 2961.02) is turned ON.

The feeding operation can be canceled and operation stopped at any point using the immediate stop switch input (IN02: CIO 2960.02).

Applicable Instructions

SPED(885) and PLS2(887) instructions

Preparations

● PLC Setup

There are no settings that need to be made in the PLC Setup.

● DM Area Settings

- Settings to Control Speed while Jogging (D0 to D3)

Setting	Word	Data
Target frequency: 1,000 pps	D0	#03E8
	D1	#0000
Target frequency: 0 pps	D2	#0000
	D3	#0000

- Settings for PLS2(887) for Fixed-distance Positioning (D10 to D20)

Setting	Word	Data
Acceleration rate: 1,000 pps/4 ms	D10	#03E8
Deceleration rate: 1,000 pps/4 ms	D11	#03E8
Target frequency: 10,000 pps	D12	#2710
	D13	#0000
Number of output pulses: 50,000 pulses	D14	#C350
	D15	#0000
Starting frequency: 0 pps	D16	#0000
	D17	#0000
Counter setting: 100 times	D20	#0100

Ladder Program

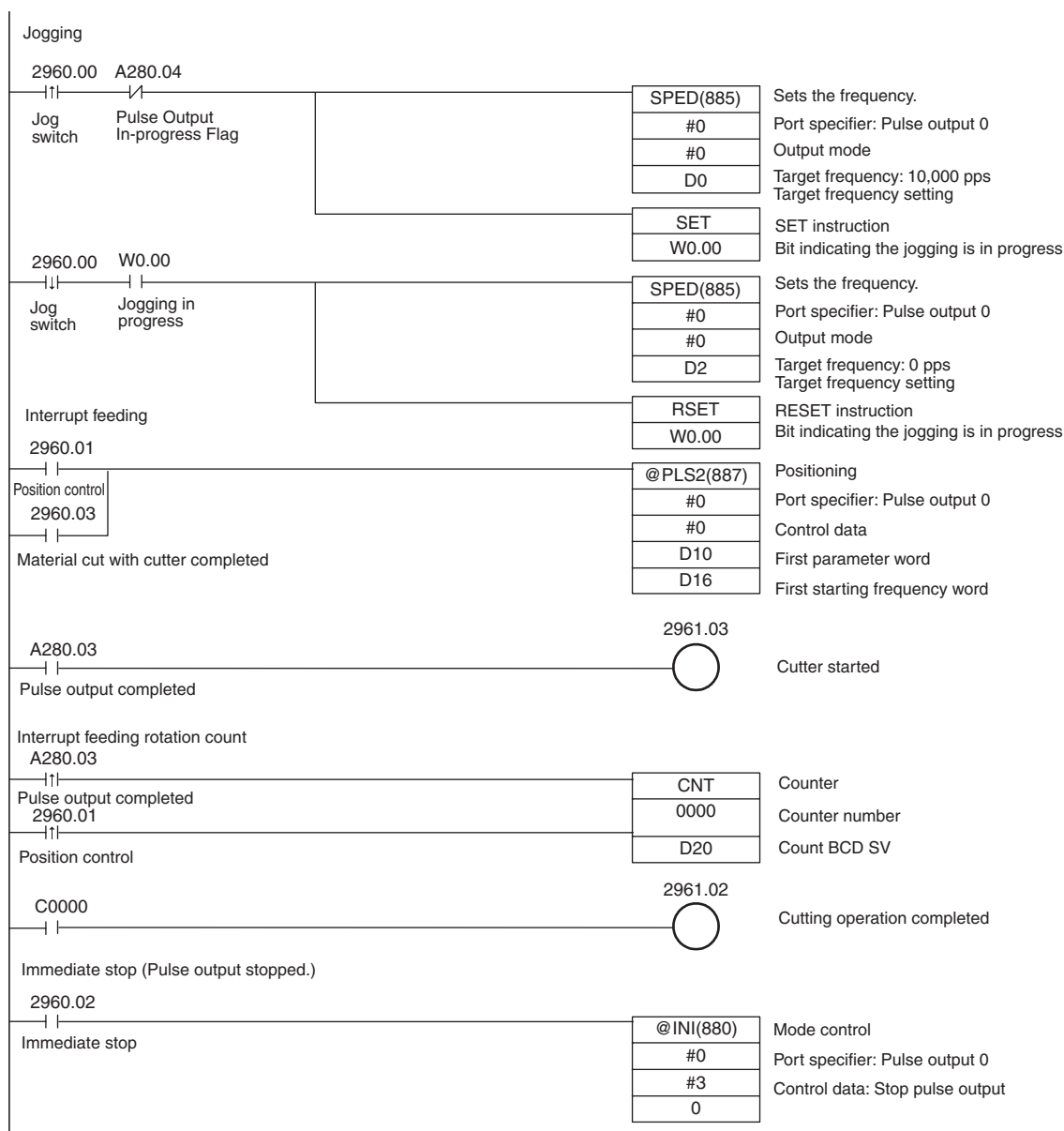

Remarks

- PLS2(887) uses a relative pulse setting. This enables operation even if the origin is not defined. The PV of pulse output 0 in A276 (lower 4 digits) and A277 (upper 4 digits) is set to 0 before pulse output and then contains the specified number of pulses.
- ACC(888) can be used instead of SPED(885) for the jog operation. If ACC(888) is used, acceleration/deceleration can be included in the jog operation.

8-9-2 Palletize: Two-axis Multipoint Positioning

Specifications and Operation

● Overview

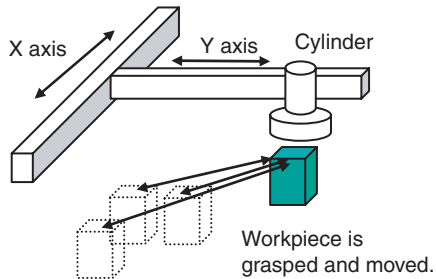

● Operation Pattern

1. Perform origin search.
2. A workpiece is grasped and moved to position A.
3. The workpiece is repeatedly moved between the grasp position and the assembly positions.

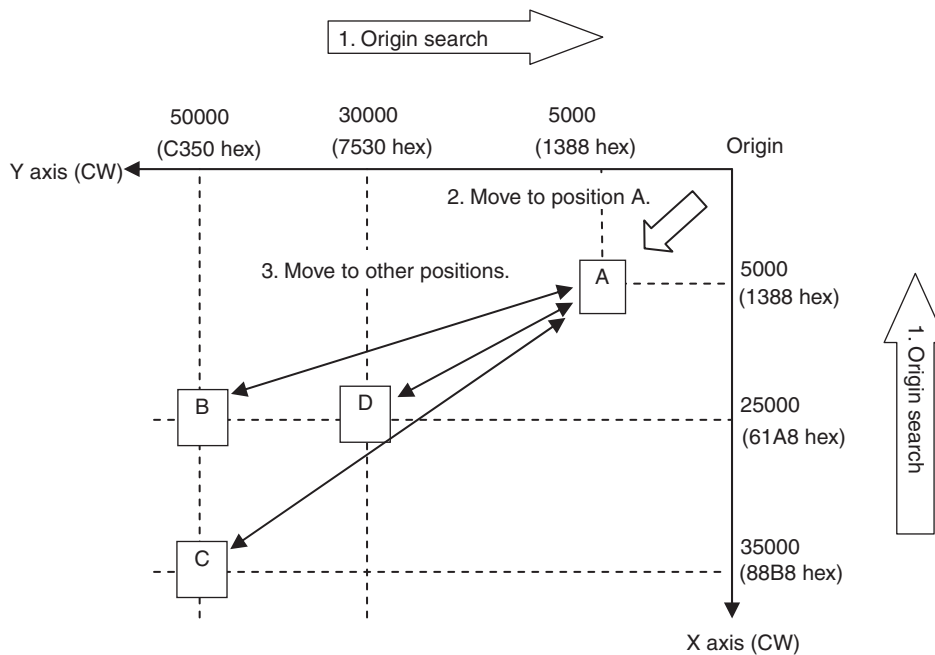

Note The X and Y axes are moved independently, i.e., interpolation is not performed.

● Wiring Example Using SMARTSTEP A-series Servo Drive, XW2Z Cables, and XW2B I/O Terminal

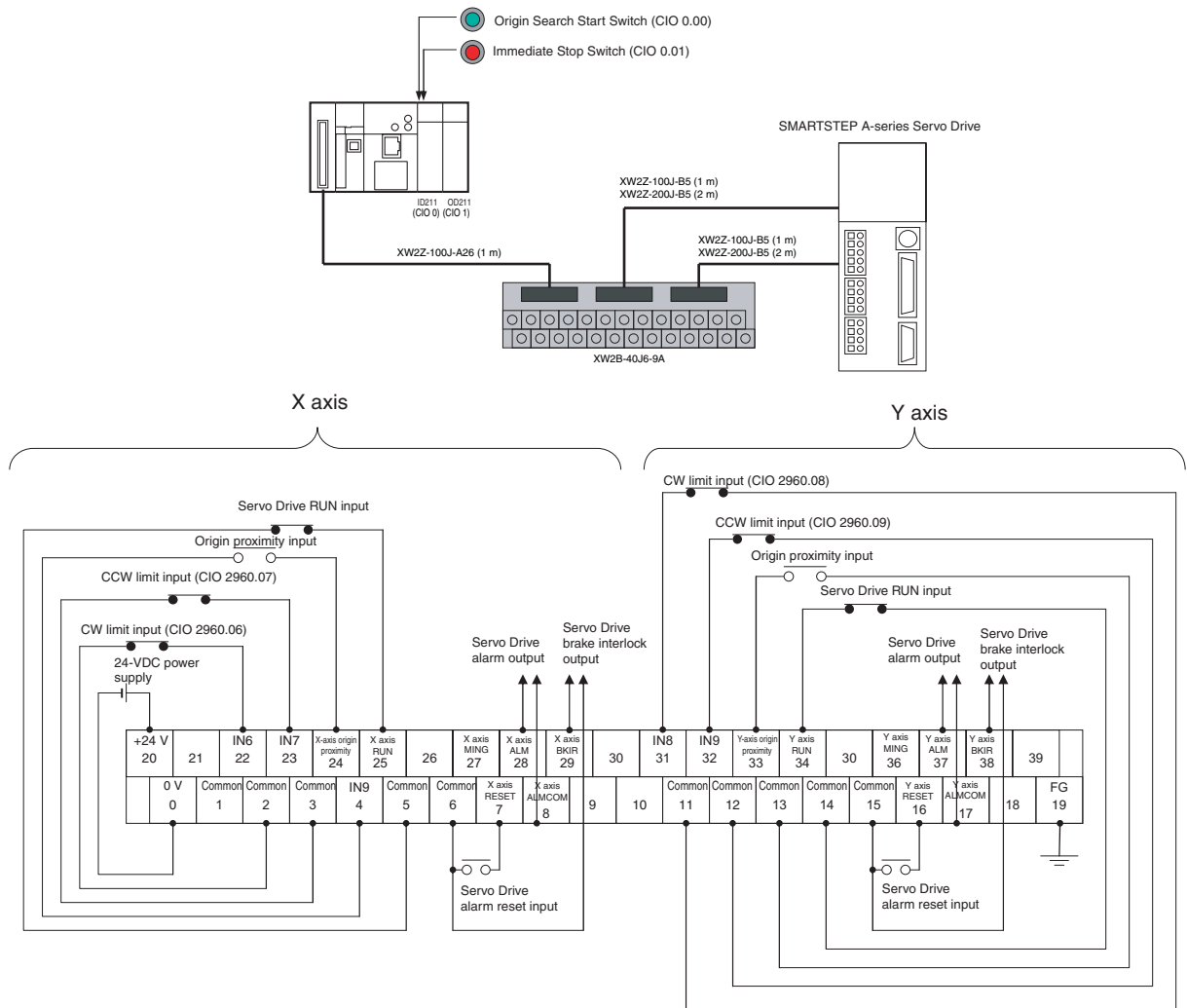

● Operation

- 1** An origin search is performed using the Origin Search Start Switch (CIO 0.00).
- 2** When the origin search is finished, the following operations are performed continuously.
 - Move in to A.
 - Move to B and return to A.
 - Move to C and return to A.
 - Move to D and return to A.
- 3** An immediate stop is executed to stop pulse output with the Immediate Stop input (CIO 0.01).

Preparations

● PLC Setup

Setting

Origin Search Detailed Settings for pulse output 0

Note The setting of the option to use the origin search is read from the PLC Setup when the power supply is turned ON.

Item		Pulse Output 0	Pulse Output 1	Pulse Output 2	
Base Setting	Limit Input Signal Operation	*Search Only	*Search Only	*Search Only	*Se
	Limit Input Signal Type	*NC (Normally Closed)	*NC (Normally Closed)	*NC (Normally Closed)	*NC
	Clear Origin at Limit Input Signal	*Hold Origin	*Hold Origin	*Hold Origin	*Hc
	Search/Return Initial Speed (pps)	0	0	0	0
Origin Search	Speed Curve	*Linear	*Linear	*Linear	*Lin
	Origin Search Setting	Enable	Enable	*Disable	*Dis
	Search Direction	*CW	*CW	*CW	*CW
	Origin Detected after Prox. Input	0: Turns ON and then	0: Turns ON and then	0: Turns ON and then	0: 1
	Origin Search at Limit Input	*0: Reverse	*0: Reverse	*0: Reverse	*0:
	Operation Mode	*Mode 0: Stepping Mo	*Mode 0: Stepping Mo	*Mode 0: Stepping Mo	*Mc
	-Error Counter Reset Output	Not Output	Not Output	Not Output	Not
	-In-position Input	Do not Use	Do not Use	Do not Use	Do
	Origin Input Signal Type	*NC (Normally Closed)	*NC (Normally Closed)	*NC (Normally Closed)	*NC
	Proximity Input Signal Type	*NC (Normally Closed)	*NC (Normally Closed)	*NC (Normally Closed)	*NC
	High Speed (pps)	100000	100000	0	0
	Proximity Speed (pps)	50000	50000	0	0
	Correction Value	0	0	0	0
	Acceleration Rate	2000	2000	0	0
Deceleration Rate	2000	2000	0	0	
Origin Return	Positioning Monitor Time (ms)	0	0	0	0
	Target Speed (pps)	0	0	0	0
	Acceleration Rate	0	0	0	0
	Deceleration Rate	0	0	0	0

Default settings are indicated by asterisks.

Internal Pulse Control Cycle: *4ms 1ms

Copy Pulse Output Settings: Copy, Defaults, Help, OK, Cancel

● DM Area Settings

- Starting Frequency

Setting	Word	Data
X axis starting frequency	D0	#0000
Y axis starting frequency	D2	#0000

- PLS2(887) Settings to Move from Origin to Position A

Setting	Word	Data	
X axis	Acceleration rate: 2,000 pps/4 ms	D10	#07D0
	Deceleration rate: 2,000 pps/4 ms	D11	#07D0
	Target frequency: 100,000 pps	D12	#86A0
		D13	#0001
	Number of output pulses: 5,000 pulses	D14	#1388
D15		#0000	
Y axis	Acceleration rate: 2,000 pps/4 ms	D20	#07D0
	Deceleration rate: 2,000 pps/4 ms	D21	#07D0
	Target frequency: 100,000 pps	D22	#86A0
		D23	#0001
	Number of output pulses: 5,000 pulses	D24	#1388
D25		#0000	

- Settings to Move from Position A to Position B

	Setting	Word	Data
X axis	Acceleration rate: 2,000 pps/4 ms	D30	#07D0
	Deceleration rate: 2,000 pps/4 ms	D31	#07D0
	Target frequency: 100,000 pps	D32	#86A0
		D33	#0001
	Number of output pulses: 25,000 pulses	D34	#61A8
D35		#0000	
Y axis	Acceleration rate: 2,000 pps/4 ms	D40	#07D0
	Deceleration rate: 2,000 pps/4 ms	D41	#07D0
	Target frequency: 100,000 pps	D42	#86A0
		D43	#0001
	Number of output pulses: 50,000 pulses	D44	#C350
D45		#0000	

- Settings to Move from Position A to Position C

	Setting	Word	Data
X axis	Acceleration rate: 2,000 pps/4 ms	D50	#07D0
	Deceleration rate: 2,000 pps/4 ms	D51	#07D0
	Target frequency: 100,000 pps	D52	#86A0
		D53	#0001
	Number of output pulses: 35,000 pulses	D54	#88B8
D55		#0000	
Y axis	Acceleration rate: 2,000 pps/4 ms	D60	#07D0
	Deceleration rate: 2,000 pps/4 ms	D61	#07D0
	Target frequency: 100,000 pps	D62	#86A0
		D63	#0001
	Number of output pulses: 50,000 pulses	D64	#C350
D65		#0000	

- Settings to Move from Position A to Position D

	Setting	Word	Data
X axis	Acceleration rate: 2,000 pps/4 ms	D70	#07D0
	Deceleration rate: 2,000 pps/4 ms	D71	#07D0
	Target frequency: 100,000 pps	D72	#86A0
		D73	#0001
	Number of output pulses: 25,000 pulses	D74	#61A8
D75		#0000	
Y axis	Acceleration rate: 2,000 pps/4 ms	D80	#07D0
	Deceleration rate: 2,000 pps/4 ms	D81	#07D0
	Target frequency: 100,000 pps	D82	#86A0
		D83	#0001
	Number of output pulses: 30,000 pulses	D84	#7530
D85		#0000	

Ladder Program

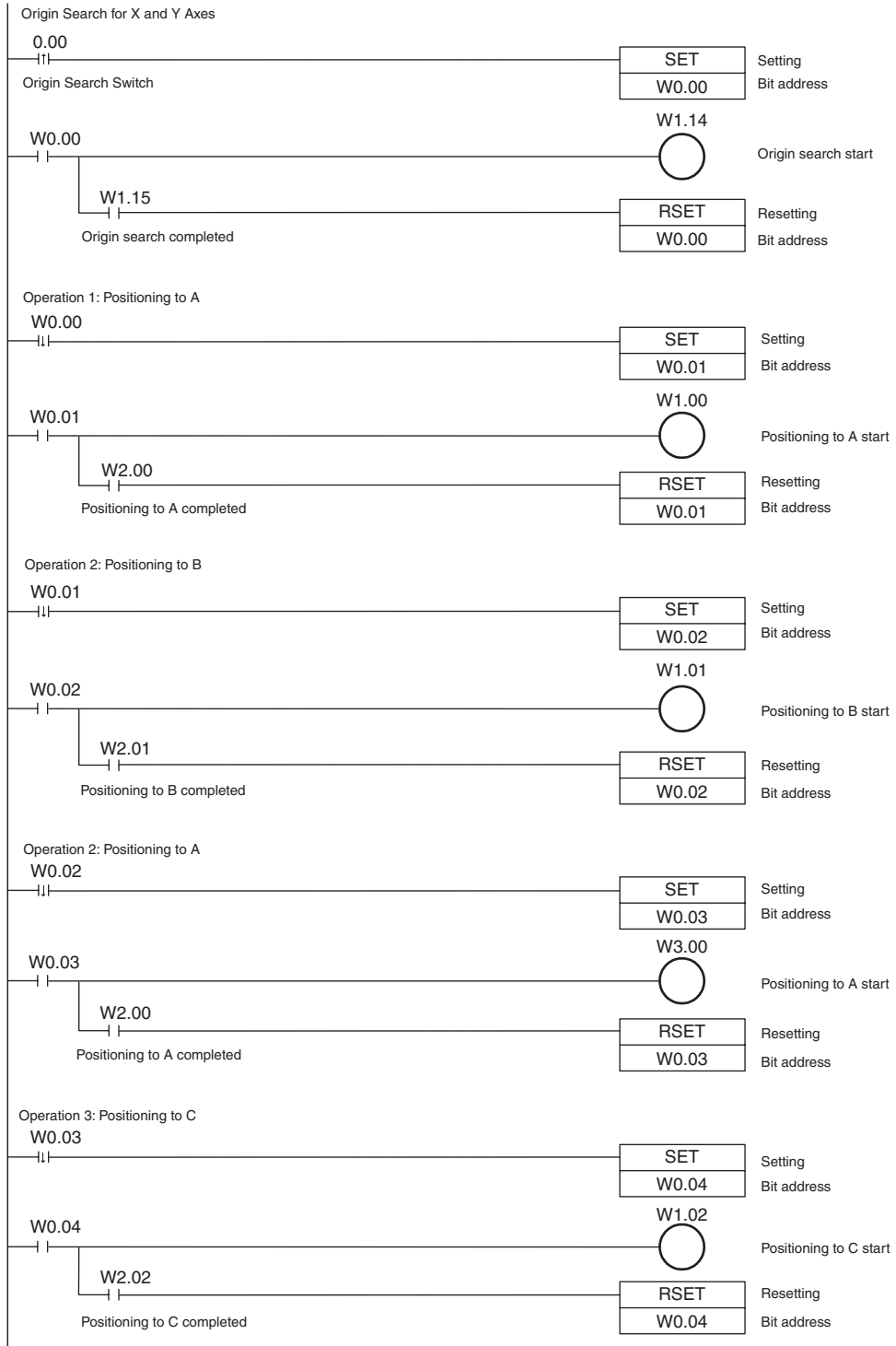

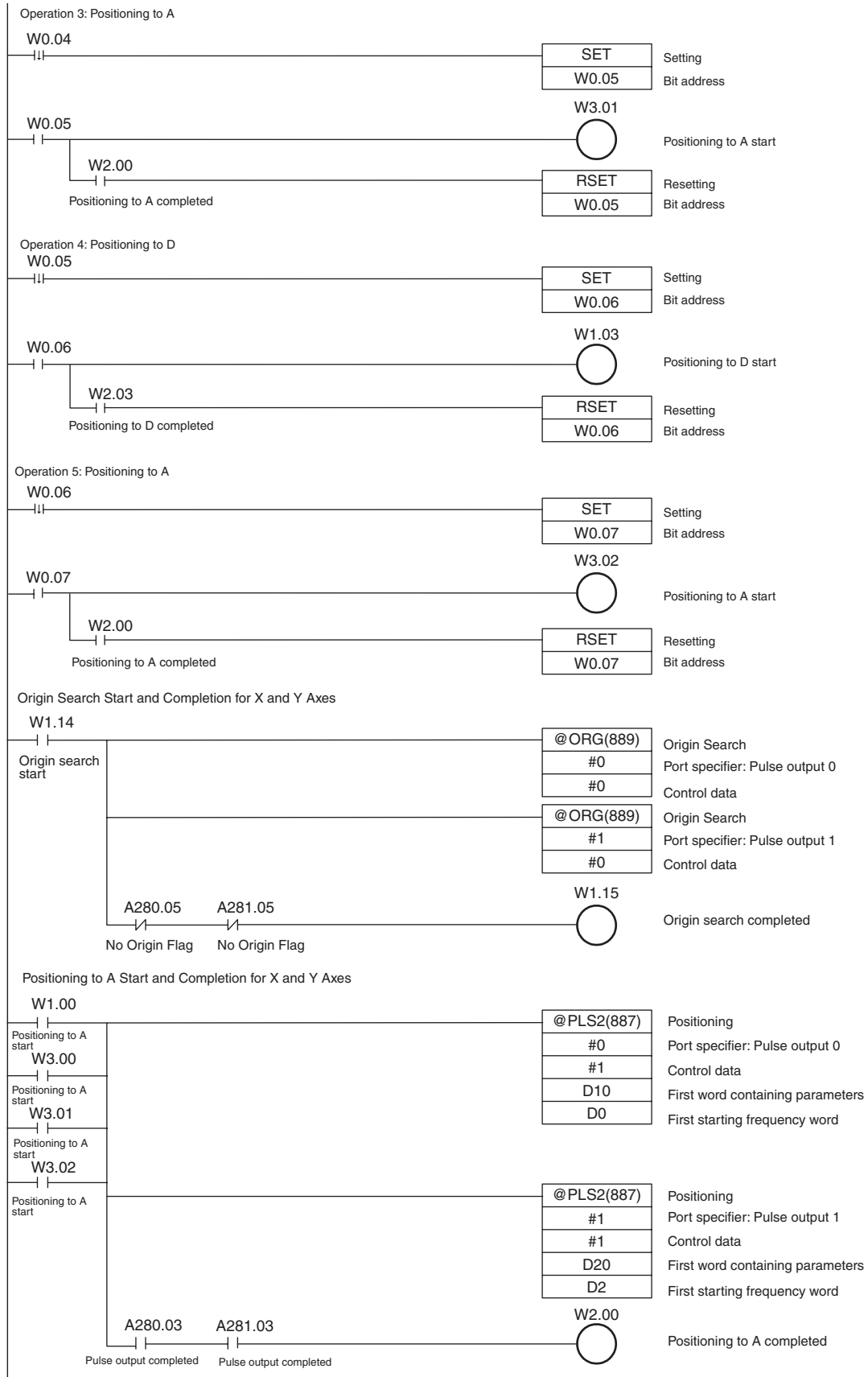

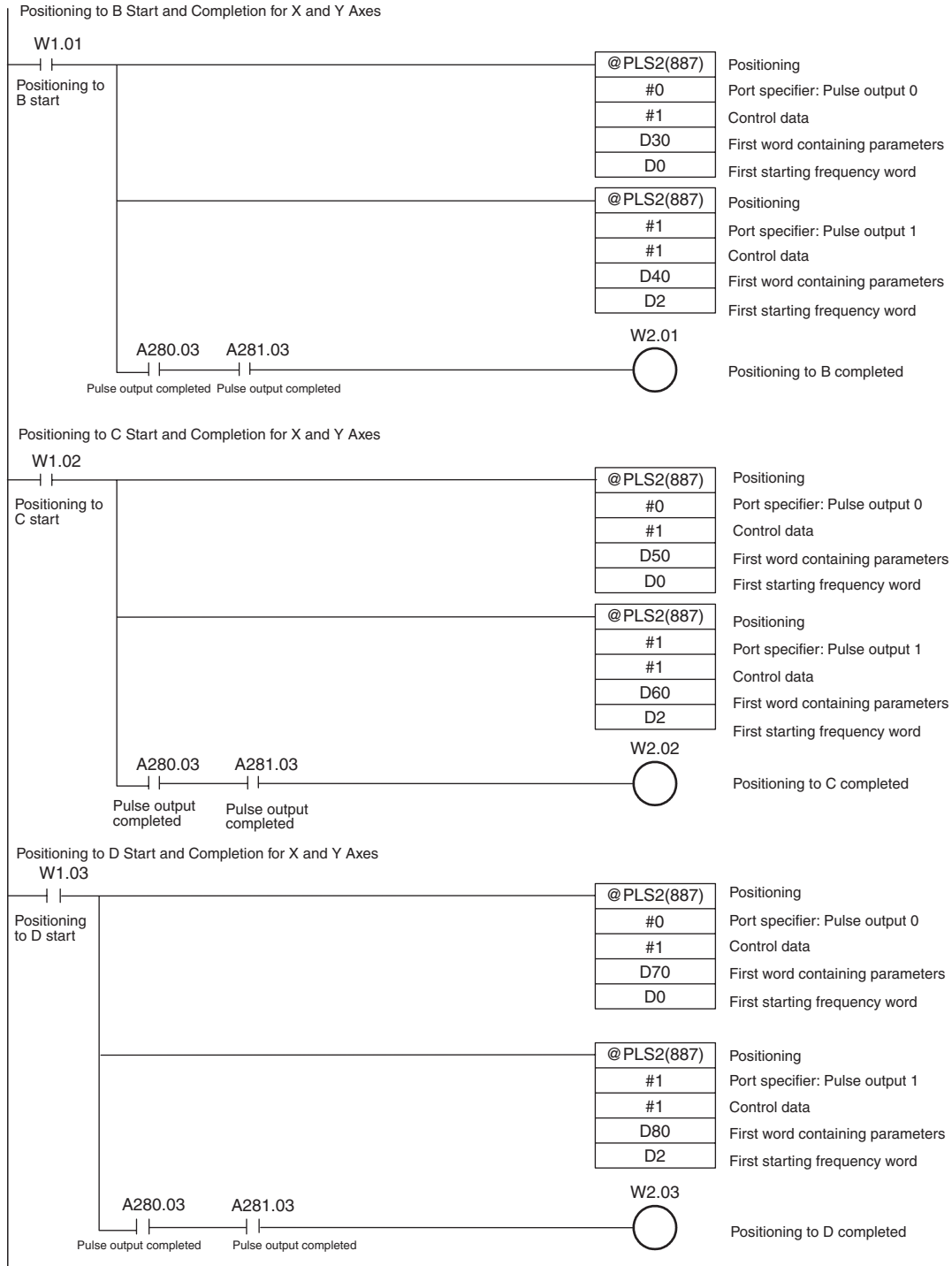

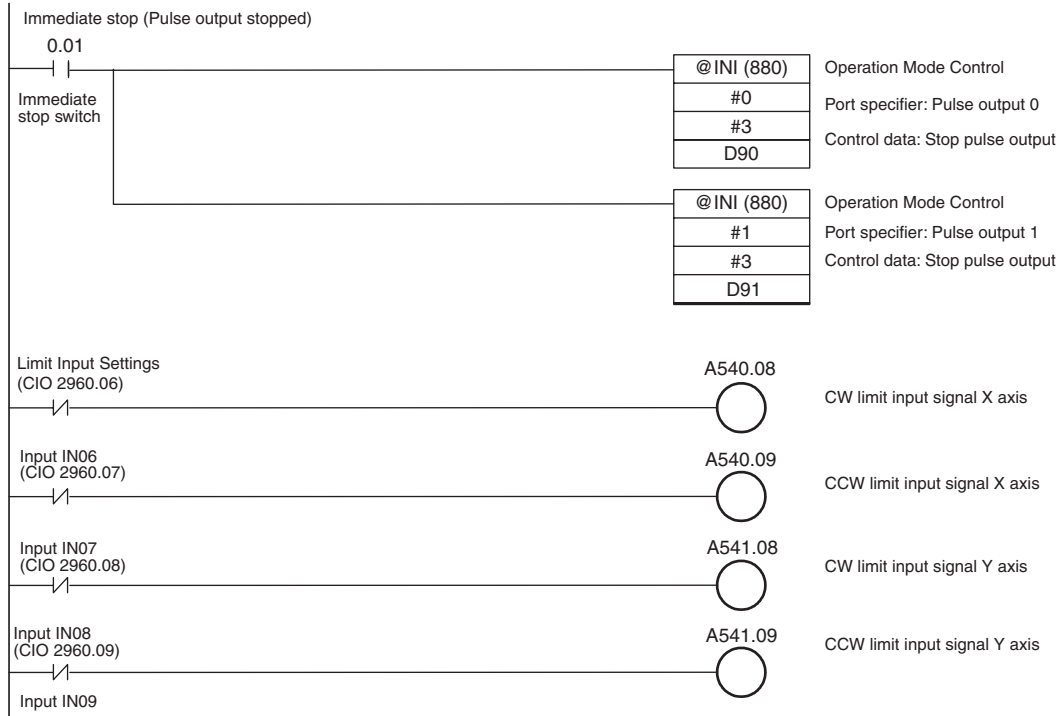

8-9-3 Vertically Conveying PCBs (Multiple Progressive Positioning)

Specifications and Operation

● Overview

- ① PCBs with components mounted are stored in a stoker.
- ② When the stoker becomes full, it is moved to the conveyance point.

Positioning Operation for Vertical Conveyor

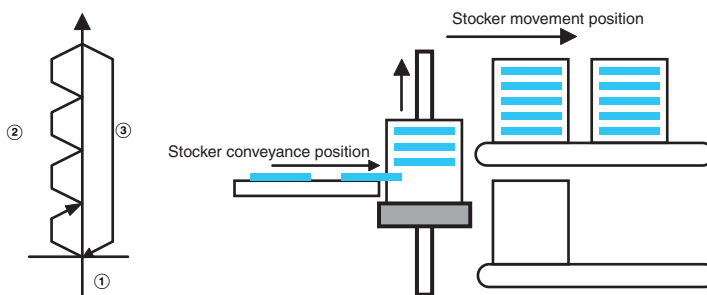

● Operation Pattern

- ① Perform origin search.
- ② Fixed-distance positioning is repeated.
- ③ The system returns to the original position.

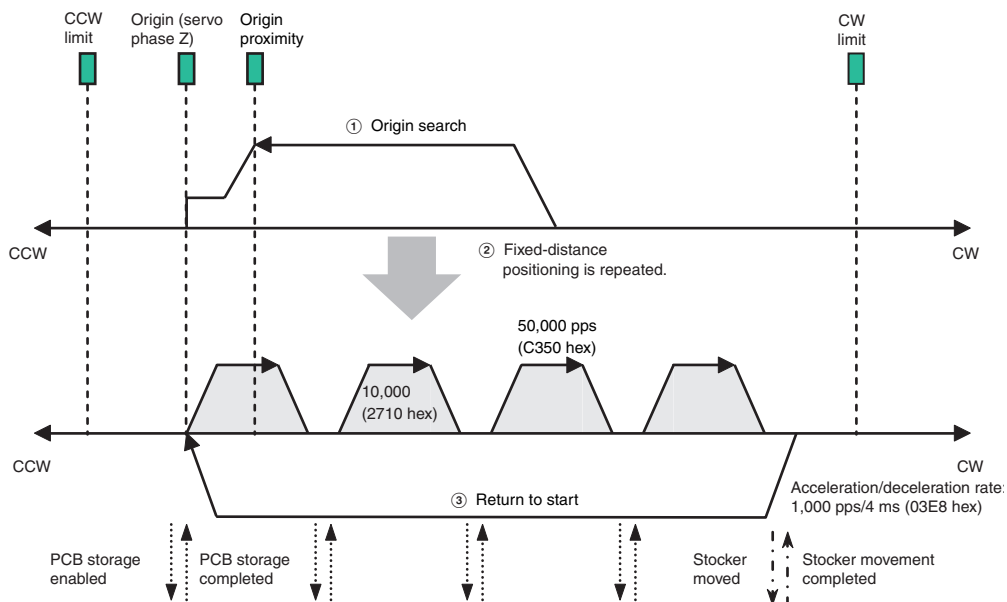

● Wiring Example Using SMARTSTEP A-series Servo Drive

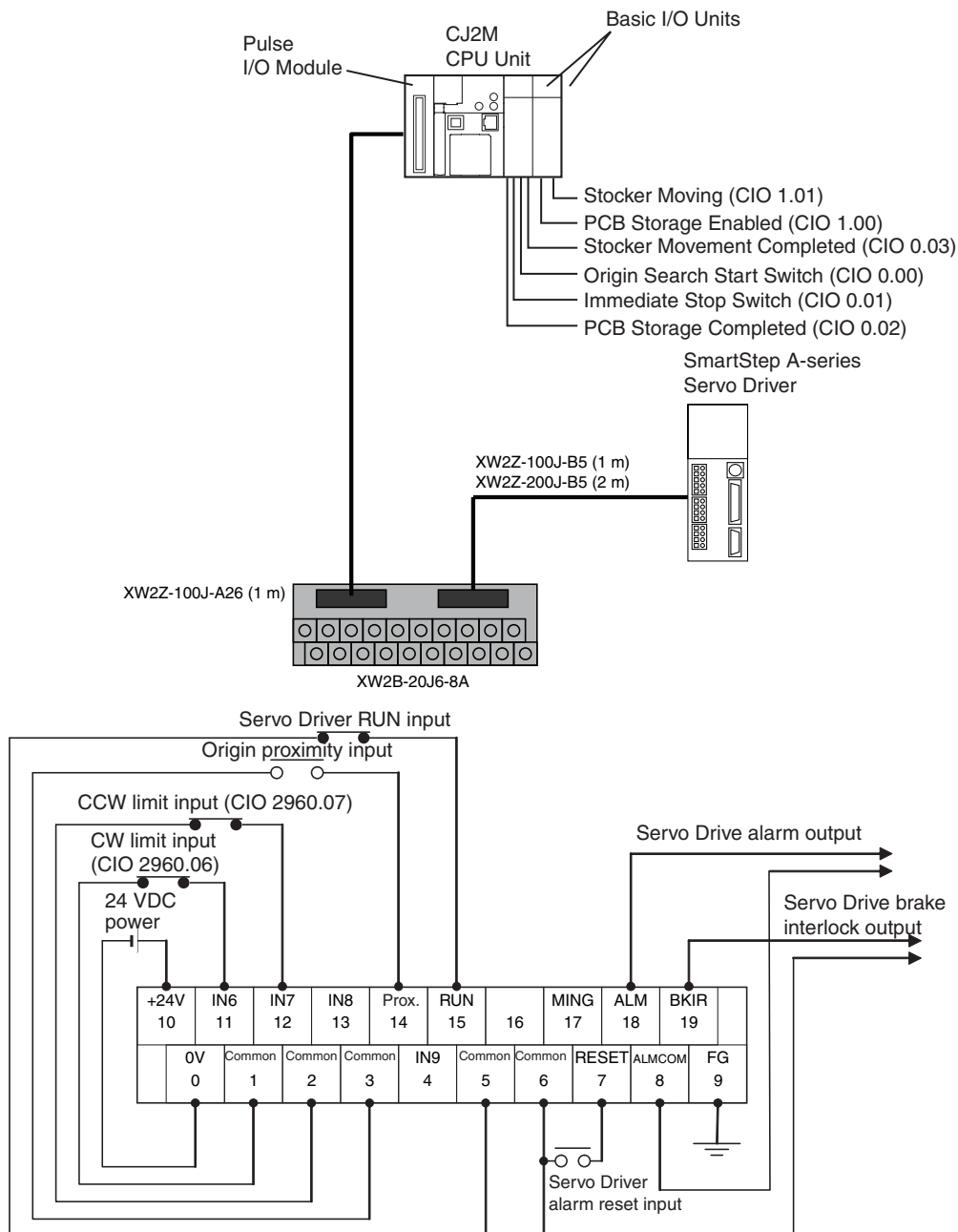

● Operation

- 1** An origin search is performed using the origin search start switch (CIO 0.00).
- 2** When the origin search is finished, the PCB storage enabled output (CIO 1.00) is turned ON.
- 3** When a PCB has been stored, the stocker is raised (relative positioning) using the PCB Storage Completed Input (CIO 0.02).
- 4** Storing PCBs is repeated until the stocker is full.

- 5 The number of PCBs in the stoker is counted with counter C0 by counting the number of times the stoker is raised.
- 6 When the stoker is full, it is moved (CIO 1.01) and only the conveyor is lowered (absolute positioning) when stoker movement is completed (CIO 0.03).
- 7 An immediate stop is executed to stop pulse output with the immediate stop switch input (CIO 0.01).

Preparations

- PLC Setup

Setting

Enable the origin search setting for pulse output 0.

Note The setting of the option to use the origin search is read from the PLC Setup when the power supply is turned ON.

Item		Pulse Output 0	Pulse Output 1	Pulse Output 2	
Base Setting	Limit Input Signal Operation	*Search Only	*Search Only	*Search Only	*Se
	Limit Input Signal Type	*NC (Normally Closed)	*NC (Normally Closed)	*NC (Normally Closed)	*NC
	Clear Origin at Limit Input Signal	*Hold Origin	*Hold Origin	*Hold Origin	*Hc
	Search/Return Initial Speed (pps)	0	0	0	0
	Speed Curve	*Linear	*Linear	*Linear	*Lir
Origin Search	Origin Search Setting	Enable	Enable	*Disable	*Di
	Search Direction	*CW	*CW	*CW	*CV
	Origin Detected after Prox. Input	0: Turns ON and then	0: Turns ON and then	0: Turns ON and then	0: 1
	Origin Search at Limit Input	*0: Reverse	*0: Reverse	*0: Reverse	*0:
	Operation Mode	*Mode 0: Stepping Mo	*Mode 0: Stepping Mo	*Mode 0: Stepping Mo	*Mc
	-Error Counter Reset Output	Not Output	Not Output	Not Output	Not
	-In-position Input	Do not Use	Do not Use	Do not Use	Do
	Origin Input Signal Type	*NC (Normally Closed)	*NC (Normally Closed)	*NC (Normally Closed)	*NC
	Proximity Input Signal Type	*NC (Normally Closed)	*NC (Normally Closed)	*NC (Normally Closed)	*NC
	High Speed (pps)	100000	100000	0	0
	Proximity Speed (pps)	50000	50000	0	0
	Correction Value	0	0	0	0
	Acceleration Rate	2000	2000	0	0
Deceleration Rate	2000	2000	0	0	
Positioning Monitor Time (ms)	0	0	0	0	
Origin Return	Target Speed (pps)	0	0	0	0
	Acceleration Rate	0	0	0	0
	Deceleration Rate	0	0	0	0

Default settings are indicated by asterisks.

Internal Pulse Control Cycle: *4ms 1ms

Copy Pulse Output Settings:

● DM Area Settings

- Settings for PLS2(887) for Fixed-distance Positioning (D0 to D7)

Setting	Word	Data
Acceleration rate: 1,000 pps/4 ms	D0	#03E8
Deceleration rate: 1,000 pps/4 ms	D1	#03E8
Target frequency: 50,000 pps	D2	#C350
	D3	#0000
Number of output pulses: 10,000 pulses	D4	#2710
	D5	#0000
Starting frequency: 0 pps	D6	#0000
	D7	#0000

- Settings for PLS2(887) to Return to Start (D10 to D17)

Setting	Word	Data
Acceleration rate: 300 pps/4 ms	D10	#012C
Deceleration rate: 200 pps/4 ms	D11	#00C8
Target frequency: 50,000 pps	D12	#C350
	D13	#0000
Number of output pulses: 0 pulses	D14	#0000
	D15	#0000
Starting frequency: 100 pps	D16	#0064
	D17	#0000

- Number of Repeats of Fixed-distance Positioning Operation (D20)

Setting	Word	Data
Number of repeats of fixed-distance positioning operation (number of PCBs in stocker)	D20	#000F

Ladder Program

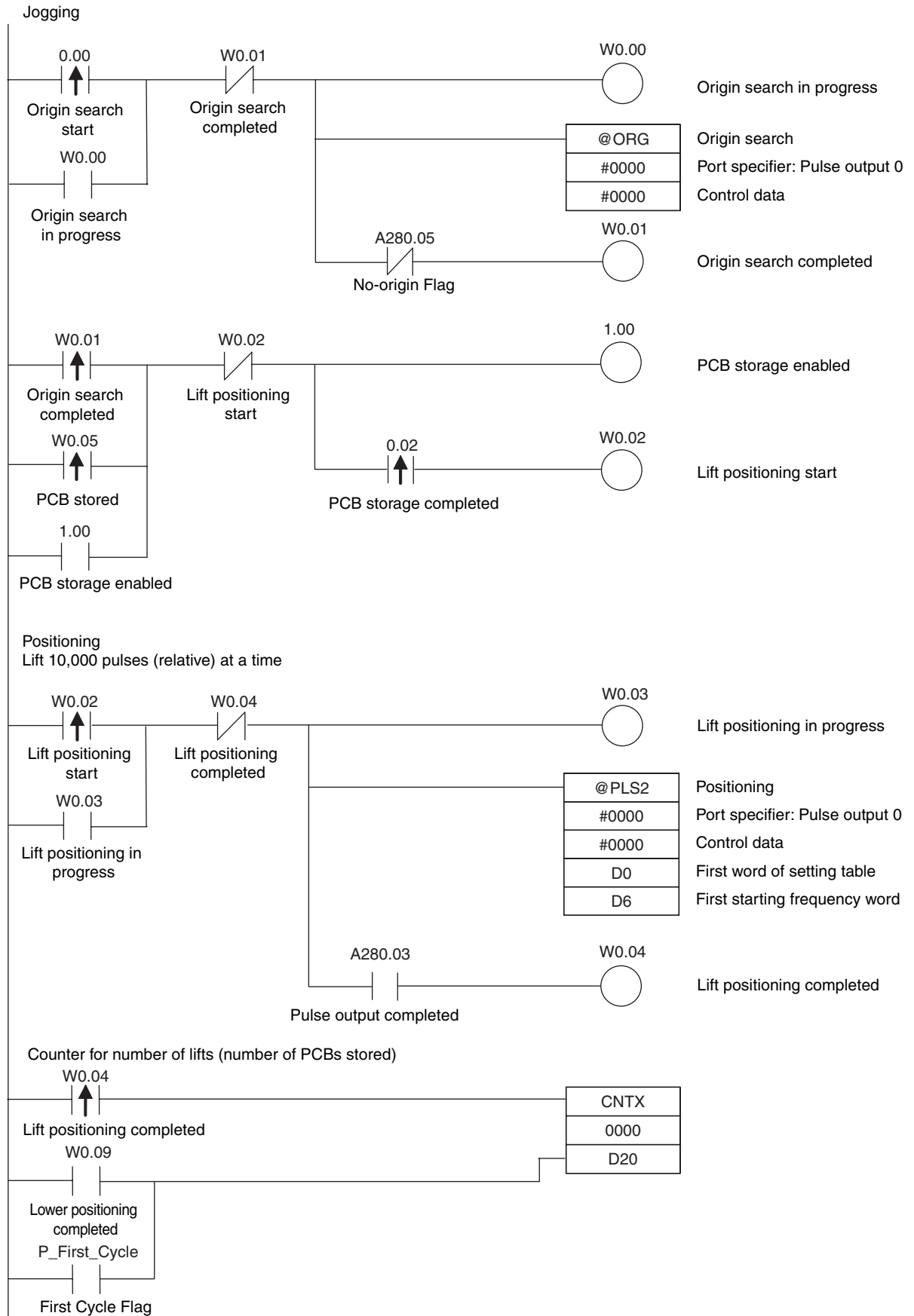

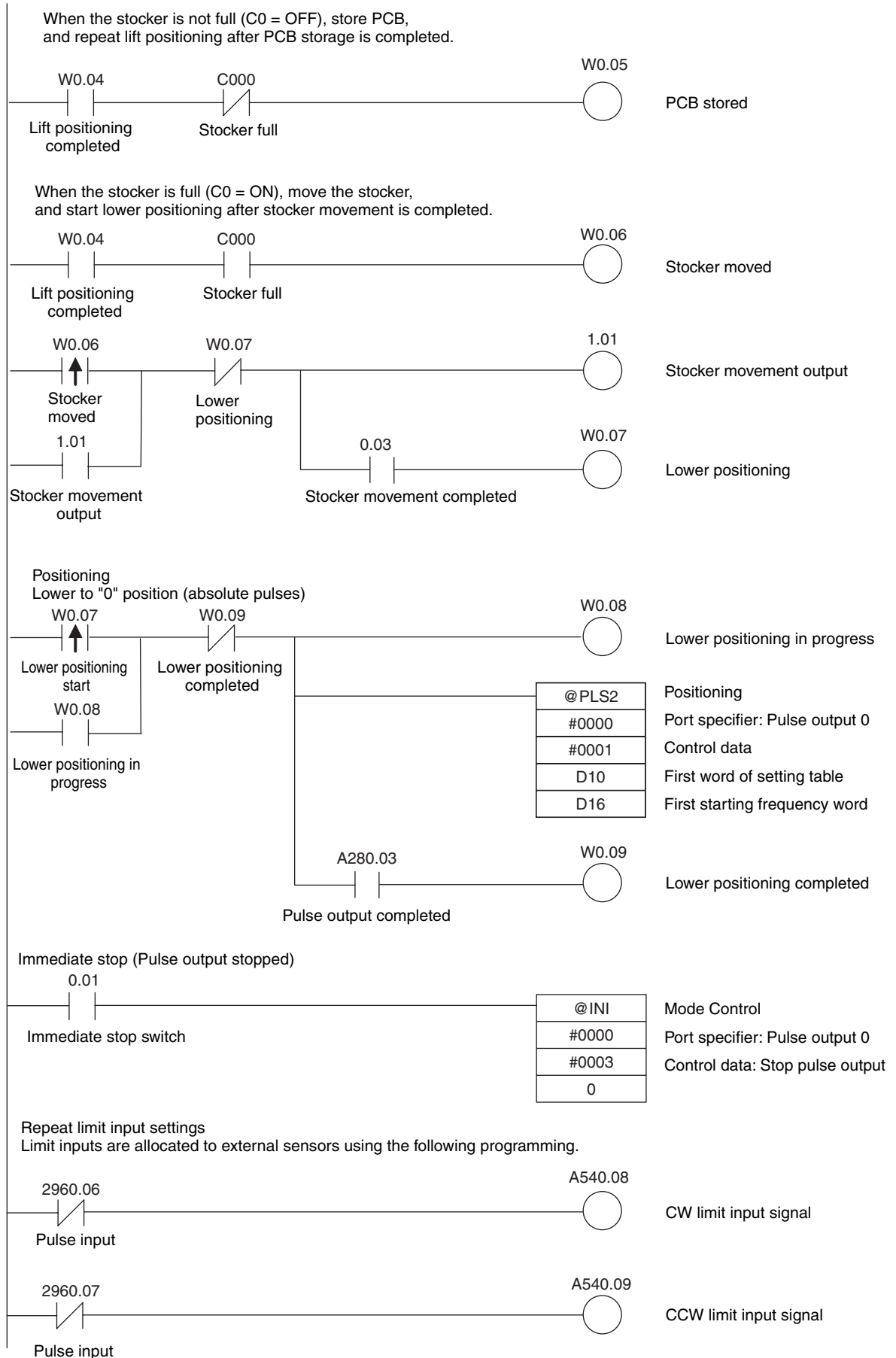

8-9-4 Feeding Wrapping Material: Interrupt Feeding

Specifications and Operation

● Feeding Wrapping Material in a Vertical Pillow Wrapper

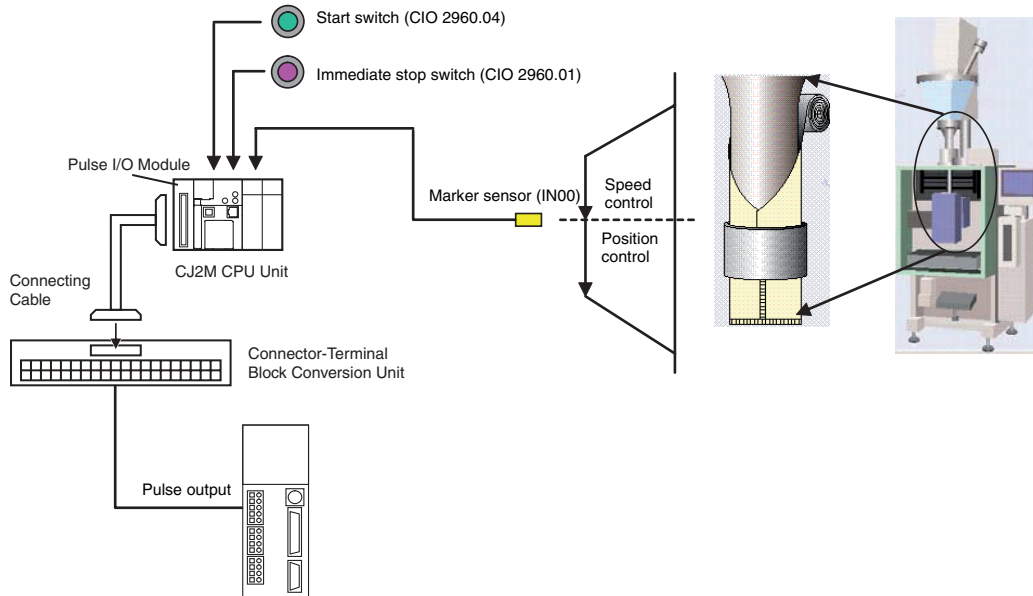

● Operation Pattern

Speed control is used to feed wrapping material to the initial position. When the marker sensor input is received, fixed-distance positioning is performed before stopping.

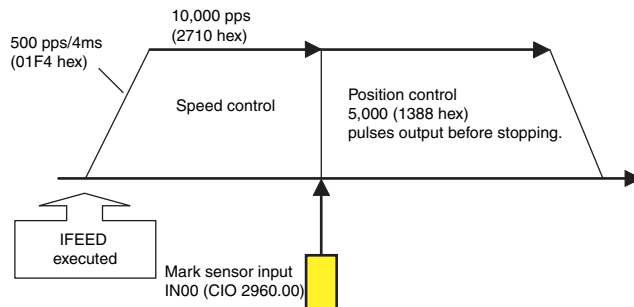

● Operation

- 1** Speed control is used to feed wrapping material to the initial position by executing the IFEED(892) instruction when the start switch (CIO 2960.04) is activated.
- 2** When the mark sensor input (CIO 2960.00) turns ON, operation is switched to position control.
- 3** The axis is moved the specified travel amount and then stopped.
- 4** An immediate stop is executed to stop pulse output with the immediate stop switch input (CIO 2960.01).

Preparations

● PLC Setup

Setting
Enable using input IN00 as interrupt input.

Note The interrupt input setting is read from the PLC Setup when the power supply is turned ON.

● DM Area Settings

- Speed Control Settings to Feed Wrapping Material to Initial Position and Positioning Control Settings for Wrapping Material

Setting	Word	Data
Acceleration rate: 500 pps/4 ms	D10	#01F4
Deceleration rate: 500 pps/4 ms	D11	#01F4
Target frequency: 10,000 pps	D12	#2710
	D13	#0000
Number of output pulses: 5,000 pulses	D14	#1388
	D15	#0000

Ladder Program

● Cyclic Task Program (Executed at Startup)

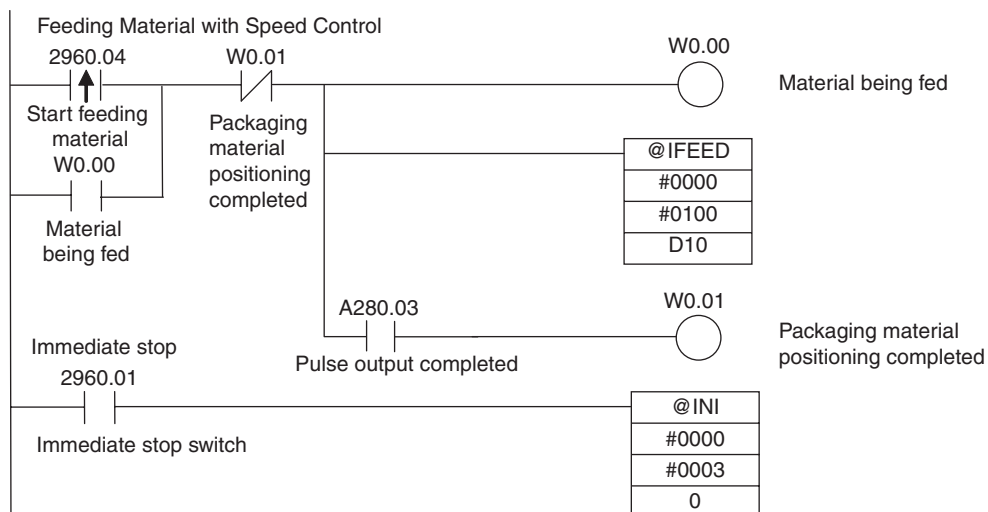

8-10 Precautions when Using Pulse Outputs

Movement Direction when Specifying Absolute Pulses

When operating with absolute pulses, the movement direction (CW/CCW) is selected automatically based on the relationship between the pulse output PV when the instruction is executed and the specified target position. The direction (CW/CCW) specified in an ACC(888), SPED(885), or PLS2(887) instruction is ignored.

Using CW/CCW Limit Inputs for Pulse Output Functions other than Origin Searches

Pulse outputs will stop according to the PLC Setup when either the CW or CCW limit input signals turns ON. It is also possible to select whether the defined origin will be cleared when a CW or CCW limit input signal turns ON for a pulse output function.

Differences between Set Frequencies and Actual Frequencies

The pulse output frequency of the Pulse I/O Module is determined by dividing the source clock frequency (33,330 MHz) by an integer ratio. Consequently, there may be a slight difference between the set frequency and the actual frequency.

And that difference increases as the frequency increases. The actual frequency can be calculated from the following equations.

● Pulse Output System

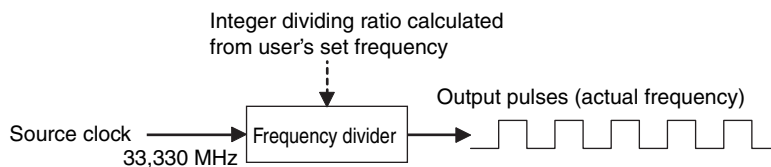

● Equations

$$\text{Actual frequency (Hz)} = \frac{\text{Source clock frequency}}{\text{Dividing ratio}}$$

$$\text{Dividing ratio} = \text{INT} \left(\frac{\text{Source clock frequency} \times 2 + \text{Set frequency}}{\text{Set frequency (Hz)} \times 2} \right)$$

The INT function extracts an integer from the fraction. The non-integer remainder is rounded.

● Differences between Set Frequencies and Actual Frequencies

Source clock frequency: 33,330 MHz

Set frequency (kHz)	Actual frequency (kHz)
99.941 to 100.000	100.090
99.642 to 99.940	99.790
:	:
50.008 to 50.082	50.045
49.933 to 50.007	49.970
:	:
10.002 to 10.004	10.003
9.999 to 10.001	10.000
9.996 to 9.998	9.997

Combinations of Pulse Control Instructions

The following tables show when a second pulse control instruction can be started if a pulse control operation is already being executed.

A second independent-mode positioning instruction can be started if an independent-mode positioning instruction is being executed, and a second continuous-mode speed control instruction can be started if a continuous-mode speed control instruction is being executed.

Operation cannot be switched between the independent and continuous modes. But a PLS2(887) instruction can be executed while a ACC(888) instruction (continuous mode) is being executed.

It is possible to start another operation during acceleration/deceleration and start another positioning instruction during positioning.

Yes: Can be executed. No: Error occurs.

Instruction being executed	Instruction being started							
	INI	SPED (Independent)	SPED (Continuous)	ACC (Independent)	ACC (Continuous)	PLS2	ORG	IFEED
SPED (Independent)	Yes	Yes (*1)	No	Yes (*3)	No	No	No	No
SPED (Continuous)	Yes	No	Yes (*2)	No	Yes (*5)	No	No	No
ACC (Independent)	Steady speed	Yes	No	No	Yes (*4)	No	Yes (*6)	No
	Accelerating or decelerating	Yes	No	No	Yes (*4)	No	Yes (*6)	No
ACC: continuous	Steady speed	Yes	No	No	No	Yes (*5)	Yes (*7)	No
	Accelerating or decelerating	Yes	No	No	No	Yes (*5)	Yes (*7)	No
PLS2	Steady speed	Yes	No	No	Yes (*4)	No	Yes (*8)	No
	Accelerating or decelerating	Yes	No	No	Yes (*4)	No	Yes (*8)	No
ORG	Steady speed	Yes	No	No	No	No	No	No
	Accelerating or decelerating	Yes	No	No	No	No	No	No
IFEED(892) instruction	Steady speed	Yes	No	No	No	No	No	Yes (*9)
	Accelerating or decelerating	Yes	No	No	No	No	No	Yes (*9)

- *1 SPED (Independent) to SPED (Independent)
 - The number of output pulses cannot be changed.
 - The frequency can be changed.
- *2 SPED (Continuous) to SPED (Continuous)
 - The frequency can be changed.
- *3 SPED (Independent) to ACC (Independent)
 - The number of output pulses cannot be changed.
 - The frequency can be changed.
 - The acceleration/deceleration rate can be changed.
- *4 ACC (Independent) to ACC (Independent) or PLS2 to ACC (Independent)
 - The number of output pulses cannot be changed.
 - The frequency can be changed.
 - The acceleration/deceleration rate can be changed. (The rate can even be changed during acceleration or deceleration.)
- *5 SPED (Continuous) to ACC (Continuous) or ACC (Continuous) to ACC (Continuous)
 - The frequency can be changed. (The target frequency can even be changed during acceleration or deceleration.)
 - The acceleration/deceleration rate can be changed. (The rate can even be changed during acceleration or deceleration.)
- *6 ACC (Independent) to PLS2
 - The number of output pulses can be changed. (The setting can even be changed during acceleration or deceleration.)
 - The frequency can be changed. (The target frequency can even be changed during acceleration or deceleration.)
 - The acceleration/deceleration rate can be changed. (The rate can even be changed during acceleration or deceleration.)
- *7 ACC (Continuous) to PLS2
 - The frequency can be changed. (The target frequency can even be changed during acceleration or deceleration.)
 - The acceleration/deceleration rate can be changed. (The rate can even be changed during acceleration or deceleration.)
- *8 PLS2 to PLS2
 - The number of output pulses can be changed. (The setting can even be changed during acceleration or deceleration.)
 - The frequency can be changed. (The target frequency can even be changed during acceleration or deceleration.)
 - The acceleration/deceleration rate can be changed. (The rate can even be changed during acceleration or deceleration.)
- *9 IFEED to IFEED
 - Possible only when target frequency is 0 Hz (deceleration stop).

Origin Search Error Processing

The pulse output function of the Pulse I/O Module performs a basic error check before starting to output pulses (when the instruction is executed) and will not output pulses if the settings are incorrect.

There are other errors that can occur with the origin search function during pulse output, which may stop the pulse output.

If an error occurs that stops pulse output, the pulse output's Output Stopped Error Flag will be turned ON and the Pulse Output Stop Error code will be written to the Error Code word. Use these flags and error codes to identify the cause of the error.

The Pulse Output Stop Errors will not affect the CPU Unit's operating status. (The Pulse Output Stop Errors do not cause a fatal or non-fatal error in the CPU Unit.)

● Related Auxiliary Area Bits

Description	Setting	Pulse output 0	Pulse output 1	Pulse output 2	Pulse output 3
Pulse Output Stopped Error Flag ON when an error occurred while outputting pulses in the origin search function.	OFF: No error, ON: Error	A280.07	A281.07	A326.07	A327.07
Output Stop Error Code If a Pulse Output Stop Error occurs, the error code is written to the corresponding word.		A444	A445	A438	A439

● Pulse Output Stop Error Codes

Error name	Error code	Description	Corrective action	Operation after error
CW Limit Stop Input Signal	0100	Stopped due to a CW limit signal input.	Move in the CCW direction.	Immediate stop No effect on other port
CCW Limit Stop Input Signal	0101	Stopped due to a CCW limit signal input.	Move in the CW direction.	Immediate stop No effect on other port
No Origin Proximity Input Signal	0200	The Origin Detected after Prox Input parameter is set to 0 (Turns ON and then OFF), but no origin proximity input signal was received during the origin search.	Check the wiring of the origin proximity input signal as well as the PLC Setup's Origin Proximity Input Signal Type setting (NC or NO) and execute the origin search again.	Immediate stop No effect on other port
No Origin Input Signal	0201	The origin input signal was not received during the origin search.	Check the wiring of the origin input signal as well as the PLC Setup's Origin Input Signal Type setting (NC or NO) and execute the origin search again.	Immediate stop No effect on other port
Origin Input Signal Error	0202	During an origin search in operation mode 0, the origin input signal was received during the deceleration started after the origin proximity input signal was received.	Take one or both of the following steps so that the origin input signal is received after deceleration is completed. <ul style="list-style-type: none"> • Increase the distance between the origin proximity input signal sensor and origin input signal sensor. • Decrease the origin search high speed. 	Deceleration stop No effect on other port
Limit Inputs in Both Directions	0203	The origin search cannot be performed because the limit signals for both directions are being input simultaneously.	Check the wiring of the limit signals in both directions as well as the PLC Setup's Limit Signal Type setting (NC or NO) and execute the origin search again.	Operation will not start. No effect on other port
Simultaneous Origin Proximity and Limit Inputs	0204	The origin proximity input signal and the limit input signal in the search direction are being input simultaneously during an origin search.	Check the wiring of the origin proximity input signal and the limit input signal. Also check the PLC Setup's Origin Proximity Input Signal Type and Limit Signal Type settings (NC or NO) and then execute the origin search again.	Emergency stop No effect on other port
Limit Input Signal Already Being Input	0205	<ul style="list-style-type: none"> • When an origin search in one direction is being performed, the limit input signal is already being input in the origin search direction. • During an origin search that does not use the proximity input, the Origin Input Signal and the Limit Input Signal in the opposite direction (from the search direction) were ON at the same time. 	Check the wiring of the limit input signal and the PLC Setup's I/O settings. Also check the PLC Setup's Limit Signal Type setting (NC or NO) and then execute the origin search again.	Emergency stop No effect on other port

Error name	Error code	Description	Corrective action	Operation after error
Origin Proximity Input Signal Origin Reverse Error	0206	<ul style="list-style-type: none"> When an origin search with reversal at the limit is being performed, the limit input signal in the search direction was input while the origin proximity input signal was reversing. When an origin search with reversal at the limit is being performed and the origin proximity input signal is not being used, the limit input signal in the search direction was input while the origin input signal was reversing. 	Check the installation positions of the origin proximity input signal, origin input signal, and limit input signal as well as the PLC Setup's I/O settings. Also check the PLC Setup's Signal Type settings (NC or NO) for each input signal and then execute the origin search again.	Emergency stop No effect on other port
Positioning Timeout Error	0300	The Servo Drive's positioning completed signal does not turn ON within the Positioning Monitor Time specified in the PLC Setup.	Adjust the Positioning Monitor Time setting or Servo system gain setting. Check the positioning completed signal wiring, correct it if necessary, and then execute the origin search again.	No effect on other port

8-11 Pulse Output Patterns

The pulse output function of the Pulse I/O Module enables operation in Continuous Mode, for which the number of output pulses is not specified, or in Independent Mode, for which the number of output pulses is specified. Continuous Mode is used for speed control and Independent Mode is used for positioning.

8-11-1 Speed Control (Continuous Mode)

The following operations can be performed in Continuous Mode by combining instructions.

Starting a Pulse Output

Operation	Example application	Frequency changes	Function	Procedure	
				Instructions	Settings
Output with specified speed	Changing the speed (frequency) in one step		Outputs pulses at a specified frequency.	SPED (Continuous)	<ul style="list-style-type: none"> Port Pulse + direction Continuous Target frequency
Output with specified acceleration and speed	Accelerating the speed (frequency) at a fixed rate		Outputs pulses and changes the frequency at a fixed rate.	ACC (Continuous)	<ul style="list-style-type: none"> Port Pulse + direction Continuous Acceleration/deceleration rate Target frequency

Changing Settings

Operation	Example application	Frequency changes	Function	Procedure	
				Instructions	Settings
Change speed in one step	Changing the speed during operation		Changes the frequency (higher or lower) of the pulse output in one step.	SPED (Continuous) ↓ SPED (Continuous)	<ul style="list-style-type: none"> Port Continuous Target frequency

Operation	Example application	Frequency changes	Function	Procedure	
				Instructions	Settings
Change speed smoothly	Changing the speed smoothly during operation		Changes the frequency from the present frequency at a fixed rate. The frequency can be accelerated or decelerated.	ACC or SPED (Continuous) ↓ ACC (Continuous)	<ul style="list-style-type: none"> Port Continuous Target frequency Acceleration/ deceleration rate
	Changing the speed in a polyline curve during operation		Changes the acceleration or deceleration rate during acceleration or deceleration.	ACC (Continuous) ↓ ACC (Continuous)	<ul style="list-style-type: none"> Port Continuous Target frequency Acceleration/ deceleration rate
Change direction	Not supported.				

Stopping Pulse Output

Operation	Example application	Frequency changes	Function	Procedure	
				Instructions	Settings
Pulse output stopped.	Immediate stop		Stops the pulse output immediately.	SPED or ACC (Continuous) ↓ INI	<ul style="list-style-type: none"> Port Pulse output stop
Stopping pulse output	Immediate stop		Stops the pulse output immediately.	SPED or ACC (Continuous) ↓ SPED (Continuous)	<ul style="list-style-type: none"> Port Continuous Target frequency=0
Stop pulse output smoothly	Decelerate to a stop		Decelerates the pulse output to a stop.*	ACC (Continuous) ↓ ACC (Continuous)	<ul style="list-style-type: none"> Port Continuous Target frequency=0

* If ACC(888) started the operation, the original acceleration/deceleration rate will remain in effect. If SPED(885) started the operation, the acceleration/deceleration rate will be invalid and the pulse output will stop immediately.

8-11-2 Positioning Control (Independent Mode)

The following operations can be performed in Independent Mode by combining instructions.

Starting Pulse Output

Operation	Example application	Frequency changes	Function	Procedure	
				Instructions	Settings
Outputting the specified speed	Positioning without acceleration or deceleration	<p>Pulse frequency</p> <p>Target frequency</p> <p>Specified number of pulses (Specified with PULS)</p> <p>SPED instruction executed</p> <p>Outputs the specified number of pulses and then stops.</p>	Starts outputting pulses at the specified frequency and stops immediately when the specified number of pulses has been output. The target position (specified number of pulses) cannot be changed during positioning.	PULS ↓ SPED (Independent)	<ul style="list-style-type: none"> • Number of pulses • Relative or absolute pulse specification • Port • Pulse + direction • Independent • Target frequency
Simple trapezoidal control	Positioning with trapezoidal acceleration and deceleration (Same rate used for acceleration and deceleration; no starting speed). The number of pulses cannot be changed during positioning.	<p>Pulse frequency</p> <p>Target frequency</p> <p>Specified number of pulses (Specified with PULS)</p> <p>Acceleration/ deceleration rate</p> <p>ACC instruction executed.</p> <p>Outputs the specified number of pulses and then stops.</p>	Accelerates and decelerates at the same fixed rate and stops immediately when the specified number of pulses has been output.*	PULS ↓ ACC (Independent)	<ul style="list-style-type: none"> • Number of pulses • Relative or absolute pulse specification • Port • Pulse + direction • Independent • Acceleration and deceleration rate • Target frequency
Complex trapezoidal control	Positioning with trapezoidal acceleration and deceleration (Separate rates used for acceleration and deceleration; starting speed). The number of pulses can be changed during positioning.	<p>Pulse frequency</p> <p>Target frequency</p> <p>Starting frequency</p> <p>Specified number of pulses</p> <p>Acceleration rate</p> <p>Deceleration rate</p> <p>Stop frequency</p> <p>PLS2 instruction executed.</p> <p>Target frequency reached</p> <p>Deceleration point</p> <p>Output stops</p>	Accelerates and decelerates at a fixed rates. The pulse output is stopped when the specified number of pulses has been output.* The target position (specified number of pulses) can be changed during positioning.	PLS2	<ul style="list-style-type: none"> • Number of pulses • Relative or absolute pulse specification • Port • Pulse + direction • Acceleration rate • Deceleration rate • Target frequency • Starting frequency

* Triangular Control

If the specified number of pulses is less than the number required just to reach the target frequency and return to zero, the function will automatically reduce the acceleration/deceleration time and perform triangular control (acceleration and deceleration only.) An error will not occur.

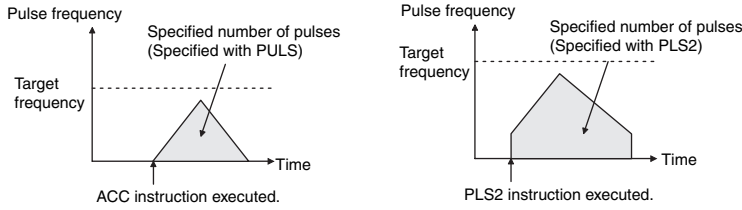

Changing Settings

Operation	Example application	Frequency changes	Function	Procedure	
				Instructions	Settings
Change speed in one step	Changing the speed in one step during operation		The SPED(885) instruction can be executed during positioning to change (raise or lower) the pulse output frequency in one step. The target position (specified number of pulses) is not changed.	PULS ↓ SPED (Independent) ↓ SPED (Independent)	<ul style="list-style-type: none"> • Number of pulses • Relative or absolute pulse specification • Port • Pulse + direction • Independent • Target frequency
Change speed smoothly (with acceleration rate = deceleration rate)	Changing the target speed (frequency) during positioning (acceleration rate = deceleration rate)		ACC(888) can be executed during positioning to change the acceleration/ deceleration rate and target frequency. The target position (specified number of pulses) is not changed.	PULS ↓ ACC (Independent) ↓ ACC (Independent) PLS2 ↓ ACC (Independent)	<ul style="list-style-type: none"> • Number of pulses • Relative or absolute pulse specification • Port • Pulse + direction • Independent • Acceleration/ deceleration rate • Target frequency

Operation	Example application	Frequency changes	Function	Procedure	
				Instructions	Settings
Change speed smoothly (with unequal acceleration and deceleration rates)	Changing the target speed (frequency) during positioning (different acceleration and deceleration rates)		<p>PLS2(887) can be executed during positioning to change the acceleration rate, deceleration rate, and target frequency.</p> <p>To prevent the target position from being changed intentionally, either operation must be continued with compensation values specified with the ACC(888) or PLS2(887) parameter change operation or the original target position must be specified as a PLS2(887) operand in absolute coordinates.</p>	<p>PULS ↓ ACC (Independent) ↓ PLS2</p> <hr/> <p>PLS2 ↓ PLS2</p>	<ul style="list-style-type: none"> • Number of pulses • Relative or absolute pulse specification • Port • Pulse + direction • Acceleration rate • Deceleration rate • Target frequency • Starting frequency
Change target position	Change the target position during positioning (multiple start function)		<p>The PLS2(887) instruction can be executed during positioning to change the target position (number of pulses).</p>	<p>PULS ↓ ACC (Independent) ↓ PLS2</p> <hr/> <p>PLS2 ↓ PLS2</p>	<ul style="list-style-type: none"> • Number of pulses • Relative or absolute pulse specification • Port • Pulse + direction • Acceleration rate • Deceleration rate • Target frequency • Starting frequency

Operation	Example application	Frequency changes	Function	Procedure	
				Instructions	Settings
Change target position and speed smoothly	Change the target position and target speed (frequency) during positioning (multiple start function)		The PLS2(887) instruction can be executed during positioning to change the target position (number of pulses), acceleration rate, deceleration rate, and target frequency.	PULS ↓ ACC (Independent) ↓ PLS2	<ul style="list-style-type: none"> • Number of pulses • Relative or absolute pulse specification • Port • Pulse + direction • Acceleration rate • Deceleration rate • Target frequency • Starting frequency
	Change the acceleration and deceleration rates during positioning (multiple start function)		The PLS2(887) instruction can be executed during positioning (acceleration or deceleration) to change the acceleration rate or deceleration rate.	PLS2 ↓ PLS2	<ul style="list-style-type: none"> • Number of pulses • Acceleration rate • Deceleration rate
Change direction	Change the direction during positioning	<p>Perform one of the following operations by setting the stop operation for reversal in operand M of PLS2(887).</p> <ul style="list-style-type: none"> • Stopping Operation for Reversal Specification: Deceleration Stop <ul style="list-style-type: none"> • Stopping Operation for Reversal Specification: Immediate Stop 	<p>The PLS2(887) instruction can be executed during positioning with absolute pulse specification to change to absolute pulses and reverse direction.</p> <p>Use Stopping Operation for Reversal Specification in operand M of the PLS2(887) instruction to specify how to stop (decelerate and stop or immediate stop) the current movement.</p>	PULS ↓ ACC (Independent) ↓ PLS2 PLS2 ↓ PLS2	<ul style="list-style-type: none"> • Number of pulses • Absolute pulse specification • Port • CW/CCW or Pulse + direction • Acceleration rate • Deceleration rate • Target frequency • Starting frequency

Stopping a Pulse Output

Operation	Example application	Frequency changes	Function	Procedure	
				Instructions	Settings
Stop pulse output (Number of pulses setting is not preserved.)	Immediate stop		Stops the pulse output immediately. Clears the current number of output pulses.	PULS ↓ ACC (Independent) or SPED (Independent) ↓ INI PLS2 ↓ INI	Stopping pulse output
Stop pulse output (Number of pulses setting is not preserved.)	Immediate stop		Stops the pulse output immediately. Clears the current number of output pulses.	PULS ↓ SPED (Independent) ↓ SPED (Independent)	<ul style="list-style-type: none"> Port Independent Target frequency = 0
Stop sloped pulse output smoothly. (Number of pulses setting is not preserved.)	Decelerate to a stop		Decelerates the pulse output to a stop. If ACC(888) started the operation, the original acceleration/deceleration rate will remain in effect. If SPED(885) started the operation, the acceleration/deceleration rate will be invalid and the pulse output will stop immediately.	PULS ↓ ACC or SPED (Independent) ↓ ACC (Independent) PLS2 ↓ ACC (Independent)	<ul style="list-style-type: none"> Port Independent Target frequency = 0

Switching from Speed Control (Continuous Mode) to Positioning (Independent Mode)

Example application	Frequency changes	Function	Procedure	
			Instructions	Settings
Change from speed control to fixed distance positioning during operation	<p>Outputs the number of pulses specified in PLS2 (Both relative and absolute pulse specification can be used.)</p> <p>ACC (continuous) executed.</p> <p>PLS2 instruction executed.</p>	The PLS2(887) instruction can be executed during a speed control operation started with ACC(888) to change to positioning operation.	ACC (Continuous) ↓ PLS2	<ul style="list-style-type: none"> • Port • Acceleration rate • Deceleration rate • Target frequency* • Number of pulses
Fixed distance feed interrupt	<p>ACC (continuous) executed.</p> <p>Execution of PLS2 with the following settings</p> <ul style="list-style-type: none"> • Number of pulses = number of pulses until stop • Relative pulse specification • Target frequency = present frequency • Acceleration rate = Not 0 • Deceleration rate = target deceleration rate 			
High-speed interrupt feeding	<p>IFEED executed</p> <p>Acceleration rate</p> <p>Target frequency</p> <p>Speed control</p> <p>Position control</p> <p>Deceleration rate</p> <p>Interrupt input occurs.</p> <p>Specified number of pulses</p>	When an interrupt input occurs during speed control for the IFEED(892) instruction, operation changes to positioning. An interrupt task is not used. There is no delay for the starting time of the interrupt task, improving the feeding accuracy.	IFEED	<ul style="list-style-type: none"> • Port • Acceleration rate • Target frequency • Pulse output set value • Deceleration rate

* The starting frequency is ignored.

9

PWM Outputs

This section describes the PWM outputs (variable duty ratio pulse outputs).

9-1	PWM Outputs (Variable Duty Ratio Pulse Outputs)	9-2
9-1-1	Overview	9-2
9-1-2	Application Procedure	9-3
9-1-3	Wiring	9-4
9-1-4	Ladder Program Example	9-5

9-1 PWM Outputs (Variable Duty Ratio Pulse Outputs)

9-1-1 Overview

A PWM (Pulse Width Modulation) pulse can be output with a specified duty ratio. The duty ratio is the ratio of the pulse's 'ON time and OFF time in one pulse cycle.

Use the PWM(891) instruction to generate PWM pulses from a pulse output.

The duty ratio can be changed during pulse output.

● Application Example

- Controlling temperature on a time-proportional basis using the PWM output.
- Controlling the brightness of lighting.

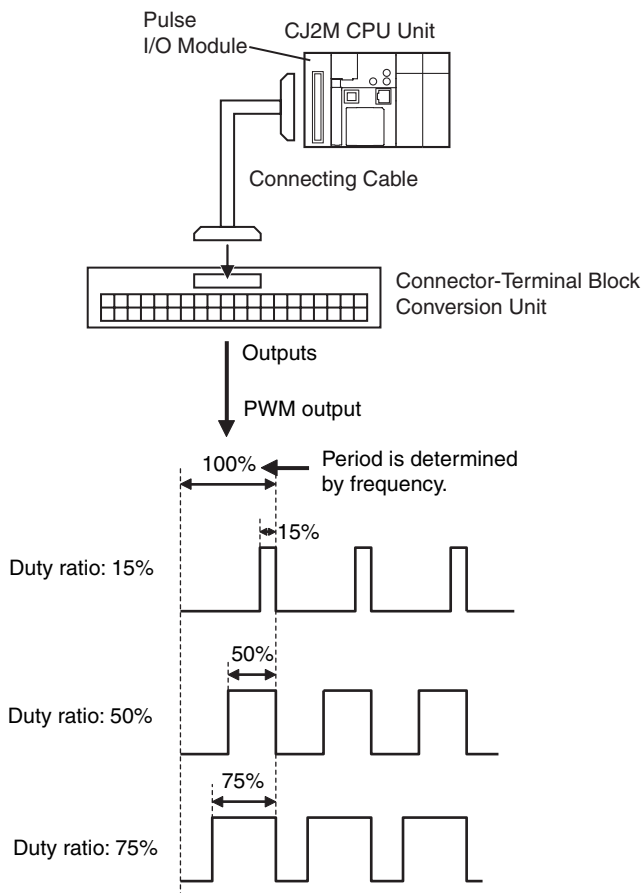

9-1-2 Application Procedure

- 1 Setting the pulse output port number, assigning pulse output terminals, and wiring PWM outputs 0 to 3 use OUT04, OUT05, OUT14, and OUT15.
- ↓
- 2 Creating ladder program Cyclic task, interrupt task
 - Execute a PWM(891) instruction.
 - PWM outputs are stopped with the INI(880) instruction.

Applicable Output Terminals

The outputs listed in the following table can be used as PWM outputs. The outputs terminals that are used for PWM outputs are also used for normal outputs and origin searches. The same output terminal can be used for only one of these functions.

For example, if PWM output 1 is used, normal output 5 and the error counter reset for pulse output 1 (when performing origin searches) cannot be used.

Terminal symbol	Word	Bit	Function	Other functions that cannot be used at the same time			
				Pulse outputs			Normal outputs
				PWM output	CW/CCW outputs	Pulse + direction outputs	
OUT04	CIO 2961	04	PWM output 0	---	---	Pulse output 0 error counter reset output (operation modes 1 and 2)	Normal output 4
OUT05		05	PWM output 1	---	---	Pulse output 1 error counter reset output (operation modes 1 and 2)	Normal output 5
OUT14	CIO 2963	04	PWM output 2	---	---	Pulse output 2 error counter reset output (operation modes 1 and 2)	Normal output 10
OUT15		05	PWM output 3	---	---	Pulse output 3 error counter reset output (operation modes 1 and 2)	Normal output 11

Related Auxiliary Area Bits

Name	Bit	Function	Read/Write	Refresh timing
PWM Output 0 Output In-progress Flag	A283.00	ON when pulses are being output from PWM output 0 to 3. OFF: Stopped, ON: Outputting	Read	<ul style="list-style-type: none"> Cleared when power is turned ON. Cleared when operation is started or stopped. Refreshed when starting/stopping pulse output.
PWM Output 1 Output In-progress Flag	A283.08			
PWM Output 2 Output In-progress Flag	A329.00			
PWM Output 3 Output In-progress Flag	A329.08			

Specifications

Item	Specifications
Duty ratio	0.0% to 100.0% in 0.1% increments (Duty ratio accuracy is +5%/-5% at 1 kHz.)
Frequency	0.1 Hz to 6,553.5 Hz (Set in 0.1-Hz increments.)* 1 Hz to 32,800 Hz (Set in 1-Hz increments.)*
Output mode	Continuous Mode
Instruction	PWM(891) instruction

* The duty ratio accuracy declines significantly at high frequencies because of limitations in the output circuit at high frequencies.

9-1-3 Wiring

Connector Pin Assignments

Pulse I/O Module No. 0 (on the right)					Pulse I/O Module No. 1 (on the left)				
Output type and number	Terminal symbol	Pin	(*1)	Description	Output type and number	Terminal symbol	(*1)	Pin	Pin
PWM output 0	OUT04	35	A18	PWM output	PWM output 2	OUT14	A18	35	PWM output
		39 or 40	A20 or B20	Output COM			A20 or B20	39 or 40	Output COM
PWM output 1 ²	OUT05	36	B18	PWM output	PWM output 3 ²	OUT15	B18	36	PWM output
		39 or 40	A20 or B20	Output COM			A20 or B20	39 or 40	Output COM

*1 Terminals numbers on the XW2D-□□G□ Connector-Terminal Block Conversion Unit.

*2 If an origin search in operation mode 1 or 2 is used for an output port 0 to 3, an instruction error will occur.

Wiring Example

This example shows how to use PWM output 0 to control the brightness of a light bulb.

Refer to 4-3-2 *Wiring Examples* for details on suppressing the load's inrush current and modify the circuit if necessary.

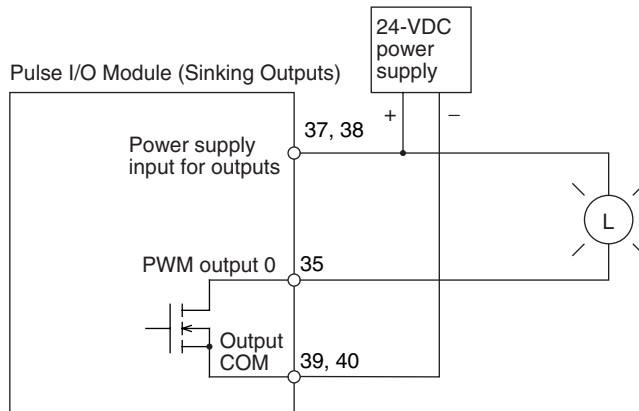

9-1-4 Ladder Program Example

Specifications and Operation

When the start input (CIO 2960.00) turns ON in this example, pulses with a duty ratio of 40% at a frequency of 2,000 Hz are output from PWM output 0. When the stop input (CIO 2960.01) turns ON, PWM output 0 is stopped.

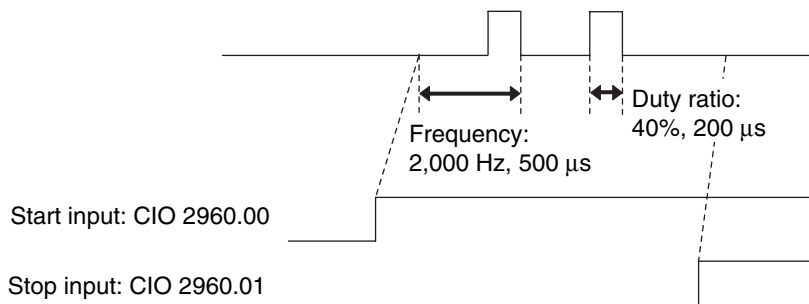

Applicable Instructions

PWM(891)

INI(880)

Preparations

● PLC Setup

There are no settings that need to be made in the PLC Setup.

● DM Area Settings

- PWM(891) Operand Settings (D0 and D1)

Settings	Word	Data
Frequency: 2,000.0 Hz	D0	#4E20
Duty ratio: 40.0%	D1	#0190

● Ladder Diagram

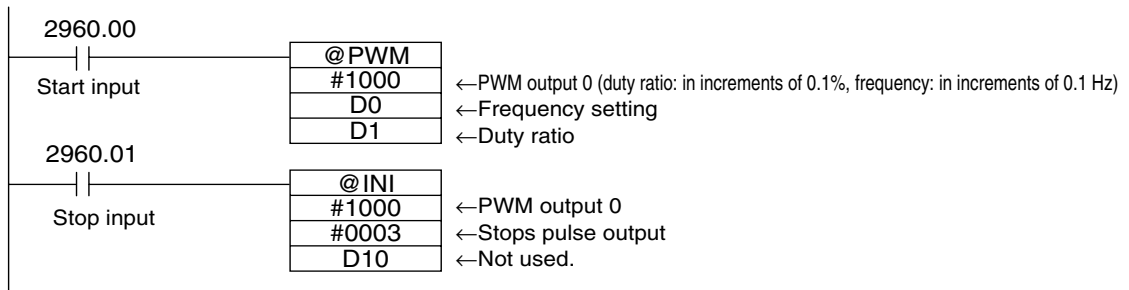

App

Appendices

A-1	Flag Operations during Pulse Output	A-2
A-2	Combinations of Pulse Control Instructions	A-3
A-3	Comparison to CJ1M Built-in I/O Functions	A-7
A-4	Performance Information	A-10
A-4-1	Interrupt Input Response Time	A-10
A-4-2	Pulse Output Start Time	A-11
A-4-3	Response Times of Pulse Output Changes	A-11

A-1 Flag Operations during Pulse Output

The flags related to pulse outputs are refreshed at the following times.

- When PULS(886) is executed
- When pulse output operation is started or stopped by SPED(885), ACC(888), PLS2(887), INI(880), or ORG(889)
- When the Reset Flag is turned ON
- When the operating status of the CPU Unit changes, i.e., when power is turned ON or when operation is started or stopped

Relationship between Flag Changes and Refresh Timing

	PVs	Accel/Decel Flags	Overflow or Underflow Flags	Setting the number of pulses	Pulse output completed	Pulse output in progress	No-origin Flag	At-origin Flag	Pulse Output Stopped Error Flag	PWM output in progress	Interrupt Feeding In-progress Flag	Interrupt Feeding Error Flag
PULS (886)	---	---	---	↑	---	---	---	---	---*3	---	---	---
SPED(885)	Changes	---	↑↓	↓	↑↓	↑↓	---	↑↓	---*3	---	---	---
ACC(888)	Changes	↑↓	↑↓	↓	↑↓	↑↓	---	↑↓	---*3	---	---	---
PLS2(887)	Changes	↑↓	↑↓	---	↑↓	↑↓	---	↑↓	---*3	---	---	---
IFEED(892)	Changes	↑↓	↑↓	↓	↑↓	↑↓	---	↑↓	---*3	---	↑↓	↑↓
PWM(891)	---	---	---	---	---	---	---	---	---*3	↑	---	---
INI(880)	Changes	↓	↓	↓	---	↓	↓	↑↓	---*3	↓	↓	---
ORG (889)	Origin search	Changes	↑↓	↓	---	↑↓	↑↓	↑	↑↓	---	---	---
	Origin return	Changes	↑↓	---	---	↑↓	↑↓	↑	---*3	---	---	---
Operation starts.	0	↓	↓	↓	↓	↓	↑	---	---*3	---	↓	↓
Operation stops.	---	↓	---	↓	↓	↓	---	---	---*3	↓	↓	---
Reset	Changes	---	↓	---	---	---	↑	↓	---*3	---	---	---
Power ON	0	↓	↓	↓	↓	↓	↑	↓	↓	↓	↓	↓
Stop at limit input with origin held ^{*1}	Changes	↓	---	---	---	↓	---	---	↑↓*3	---	↓	---
Stop at limit input with undefined origin ^{*1}	0 ^{*2}	↓	↓*2	---	---	↓	↑	---	↑↓*3	---	↓	---

---: No change, ↑ ↓: Both ON and OFF, ↑: ON Only, ↓: OFF Only, 0: Cleared to 0

*1 Operation is according to the Clear Origin at Limit Input Signal setting in the PLC Setup.

*2 The PV and Overflow/Underflow Flags are cleared when a limit input turns ON and the origin is set to be undefined.

*3 If the limit input function is set in the PLC Setup to always be enabled even when the limit input signal is set to be used for a function other than the origin search function, an error will occur if the origin input (AR) turns ON.

A-2 Combinations of Pulse Control Instructions

Instruction being executed	Pulse status	Starting instruction (factor)															
		INI		SPED (Independent)		SPED (Continuous)		ACC (Independent)		ACC (Continuous)		PLS2		IFEED		ORG	
SPED (Continuous)	Steady speed	Changing the PV	No	Output method	---	Output method	No	Output method	---	Output method	No	Output method	No	Output method	No	Output method	No
		Stopping pulses	Yes	Direction specification	---	Direction specification	No	Direction specification	---	Direction specification	No	Frequency or acceleration/deceleration	No	Frequency or acceleration/deceleration	No	Search/return	No
		---	---	Target frequency	Yes	Target frequency	No	Target frequency	Yes	Target frequency	No	Position/movement data	No	Position/movement data	No	---	---
		---	---	---	---	---	---	Acceleration/deceleration rate	Yes	Acceleration/deceleration rate	No	Starting frequency	No	Starting frequency	No	---	---
SPED (Continuous)	Steady speed	Changing the PV	No	Output method	No	Output method	---	Output method	No	Output method	---	Output method	No	Output method	No	Output method	No
		Stopping pulses	Yes	Direction specification	No	Direction specification	---	Direction specification	No	Direction specification	---	Frequency or acceleration/deceleration	No	Frequency or acceleration/deceleration	No	Search/return	No
		---	---	Target frequency	No	Target frequency	Yes	Target frequency	No	Target frequency	Yes	Position/movement data	No	Position/movement data	No	---	---
		---	---	---	---	---	---	Acceleration/deceleration rate	No	Acceleration/deceleration rate	Yes	Starting frequency	No	Starting frequency	No	---	---

A-2 Combinations of Pulse Control Instructions

App

Instruc- tion being exe- cuted	Pulse status	Starting instruction (factor)															
		INI		SPED (Inde- pendent)		SPED (Con- tinuous)		ACC (Indepen- dent)		ACC (Contin- uous)		PLS2		IFEED		ORG	
ACC (Inde- pendent)	ACC (Inde- pendent)	Changing the PV	No	Output method	No	Output method	No	Output method	---	Output method	No	Output method	---	Output method	---	Output method	No
		Stopping pulses	Yes	Direction specification	No	Direction specification	No	Direction specification	---	Direction specification	No	Frequency or acceleration/deceleration	Yes	Frequency or acceleration/deceleration	No	Search/return	No
		---	---	Target frequency	No	Target frequency	No	Target frequency	Yes	Target frequency	No	Position/movement data	Yes	Position/movement data	No	---	---
		---	---	---	---	---	---	Acceleration/deceleration rate	Yes	Acceleration/deceleration rate	No	Starting frequency	---	Starting frequency	---	---	---
	Accelerating/decelerating	Changing the PV	No	Output method	No	Output method	No	Output method	---	Output method	No	Output method	---	Output method	---	Output method	No
		Stopping pulses	Yes	Direction specification	No	Direction specification	No	Direction specification	---	Direction specification	No	Frequency or acceleration/deceleration	Yes	Frequency or acceleration/deceleration	No	Search/return	No
		---	---	Target frequency	No	Target frequency	No	Target frequency	Yes	Target frequency	×	Position/movement data	Yes	Position/movement data	No	---	---
		---	---	---	---	---	---	Acceleration/deceleration rate	Yes	Acceleration/deceleration rate	×	Starting frequency	---	Starting frequency	---	---	---
ACC (Continuous)	Steady speed	Changing the PV	No	Output method	No	Output method	No	Output method	No	Output method	---	Output method	---	Output method	---	Output method	No
		Stopping pulses	Yes	Direction specification	No	Direction specification	No	Direction specification	No	Direction specification	---	Frequency or acceleration/deceleration	Yes	Frequency or acceleration/deceleration	No	Search/return	No
		---	---	Target frequency	×	Target frequency	No	Target frequency	No	Target frequency	Yes	Position/movement data	Yes	Position/movement data	No	---	---
		---	---	---	---	---	---	Acceleration/deceleration rate	No	Acceleration/deceleration rate	Yes	Starting frequency	---	Starting frequency	---	---	---
	Accelerating/decelerating	Changing the PV	No	Output method	No	Output method	No	Output method	No	Output method	---	Output method	---	Output method	---	Output method	No
		Stopping pulses	Yes	Direction specification	No	Direction specification	No	Direction specification	No	Direction specification	---	Frequency or acceleration/deceleration	Yes	Frequency or acceleration/deceleration	No	Search/return	No
		---	---	Target frequency	No	Target frequency	No	Target frequency	No	Target frequency	Yes	Position/movement data	Yes	Position/movement data	No	---	---
		---	---	---	---	---	---	Acceleration/deceleration rate	No	Acceleration/deceleration rate	Yes	Starting frequency	---	Starting frequency	---	---	---

Instruc tion being exe- cuted	Pulse status	Starting instruction (factor)															
		INI		SPED (Inde- pendent)		SPED (Con- tinuous)		ACC (Indepen- dent)		ACC (Contin- uous)		PLS2		IFEED		ORG	
PLS2	Steady speed	Changing the PV	No	Output method	No	Output method	No	Output method	---	Output method	No	Output method	---	Output method	---	Output method	No
		Stop- ping pulses	Yes	Direc- tion specifi- cation	No	Direc- tion specifi- cation	No	Direc- tion specifi- cation	---	Direc- tion specifi- cation	No	Fre- quency or accel- eration/dec eleration	Yes	Fre- quency or accel- eration/dec eleration	No	Search/ return	No
		---	---	Target fre- quency	No	Target fre- quency	No	Target fre- quency	Yes	Target fre- quency	No	Posi- tion/mov ement data	Yes	Posi- tion/mov ement data	No	---	---
		---	---	---	---	---	---	Accel- eration/de celera- tion rate	Yes	Accel- eration/de celera- tion rate	No	Start- ing fre- quency	---	Start- ing fre- quency	---	---	---
	Accel- erating/de celerating	Changing the PV	No	Output method	No	Output method	No	Output method	---	Output method	No	Output method	---	Output method	---	Output method	No
		Stop- ping pulses	Yes	Direc- tion specifi- cation	No	Direc- tion specifi- cation	No	Direc- tion specifi- cation	---	Direc- tion specifi- cation	No	Fre- quency or accel- eration/dec eleration	Yes	Fre- quency or accel- eration/dec eleration	No	Search/ return	No
		---	---	Target fre- quency	No	Target fre- quency	No	Target fre- quency	Yes	Target fre- quency	No	Posi- tion/mov ement data	Yes	Posi- tion/mov ement data	No	---	---
		---	---	---	---	---	---	Accel- eration/de celera- tion rate	Yes	Accel- eration/de celera- tion rate	No	Start- ing fre- quency	---	Start- ing fre- quency	---	---	---
IFEED	Steady speed	Changing the PV	No	Output method	No	Output method	No	Output method	---	Output method	No	Output method	---	Output method	---	Output method	No
		Stop- ping pulses	Yes	Direc- tion specifi- cation	No	Direc- tion specifi- cation	No	Direc- tion specifi- cation	---	Direc- tion specifi- cation	No	Fre- quency or accel- eration/dec eleration	No	Fre- quency or accel- eration/dec eleration	Yes *	Search/ return	No
		---	---	Target fre- quency	No	Target fre- quency	No	Target fre- quency	No	Target fre- quency	No	Posi- tion/mov ement data	No	Posi- tion/mov ement data	No	---	---
		---	---	---	---	---	---	Accel- eration/de celera- tion rate	No	Accel- eration/de celera- tion rate	No	Start- ing fre- quency	---	Start- ing fre- quency	---	---	---
	Accel- erating or decel- erating	Changing the PV	No	Output method	No	Output method	No	Output method	---	Output method	No	Output method	---	Output method	---	Output method	No
		Stop- ping pulses	Yes	Direc- tion specifi- cation	No	Direc- tion specifi- cation	No	Direc- tion specifi- cation	---	Direc- tion specifi- cation	No	Fre- quency or accel- eration/dec eleration	No	Fre- quency or accel- eration/dec eleration	Yes *	Search/ return	No
		---	---	Target fre- quency	No	Target fre- quency	No	Target fre- quency	Yes	Target fre- quency	No	Posi- tion/mov ement data	No	Posi- tion/mov ement data	No	---	---
		---	---	---	---	---	---	Accel- eration/de celera- tion rate	Yes	Accel- eration/de celera- tion rate	No	Start- ing fre- quency	---	Start- ing fre- quency	---	---	---

Instruc- tion being exe- cuted	Pulse status	Starting instruction (factor)															
		INI		SPED (Inde- pendent)		SPED (Con- tinuous)		ACC (Indepen- dent)		ACC (Contin- uous)		PLS2		IFEED		ORG	
ORG	Steady speed	Chang- ing the PV	No	Output method	No	Output method	No	Output method	No	Output method	No	Output method	No	Output method	No	Output method	No
		Stop- ping pulses	Yes	Direc- tion specifi- cation	No	Direc- tion specifi- cation	No	Direc- tion specifi- cation	No	Direc- tion specifi- cation	No	Fre- quency or accel- eration/de- celeration	No	Fre- quency or accel- eration/de- celeration	No	Search/ return	No
		---	---	Target fre- quency	No	Target fre- quency	No	Target fre- quency	No	Target fre- quency	No	Posi- tion/mov- ement data	No	Posi- tion/mov- ement data	No	---	---
		---	---	---	---	---	---	Accel- eration/de- celera- tion rate	No	Accel- eration/de- celera- tion rate	No	Start- ing fre- quency	No	Start- ing fre- quency	No	---	---
	Accel- erat- ing or decel- erating	Chang- ing the PV	No	Output method	No	Output method	No	Output method	No	Output method	No	Output method	No	Output method	No	Output method	No
		Stop- ping pulses	Yes	Direc- tion specifi- cation	No	Direc- tion specifi- cation	No	Direc- tion specifi- cation	No	Direc- tion specifi- cation	No	Fre- quency or accel- eration/de- celeration	No	Fre- quency or accel- eration/de- celeration	No	Search/ return	No
		---	---	Target fre- quency	No	Target fre- quency	No	Target fre- quency	No	Target fre- quency	No	Posi- tion/mov- ement data	No	Posi- tion/mov- ement data	No	---	---
		---	---	---	---	---	---	Accel- eration/de- celera- tion rate	No	Accel- eration/de- celera- tion rate	No	Start- ing fre- quency	No	Start- ing fre- quency	No	---	---

Yes: Can be executed., No: Instruction Error will occur. (Error Flag ON), ---: Ignored. (Instruction error won't occur.)

* Only possible for a target frequency of 0.

A-3 Comparison to CJ1M Built-in I/O Functions

Item		Specification/performance		
		CJ2M with Pulse I/O Module	CJ1M built-in I/O	
Normal inputs	Number of inputs	20 inputs (10 × 2 Pulse I/O Modules)	10 inputs	
	Input response time	ON response time: 8 ms max. OFF response time: 8 ms max.	ON response time: 8 ms max. OFF response time: 8 ms max.	
	Differences in operation	Update timing for PLC Setup	Update timing for input constants: When power is turned ON	
Normal outputs	Number of outputs	12 outputs (6 × 2 Pulse I/O Modules)	6 outputs	
	Output response time	ON response time: 0.1 ms max. OFF response time: 0.1 ms max.	ON response time: 0.1 ms max. OFF response time: 0.1 ms max.	
	Maximum switching capacity	4.75 to 26.4 VDC 0.3 A/output; 1.8 A/Unit	4.75 to 26.4 VDC 0.3 A/output; 1.8 A/Unit	
	Output type	Sinking (CJ2M-MD211) Sourcing (CJ2M-MD212)	Sinking	
Quick-response inputs	Number of inputs	8 inputs (4 × 2 Pulse I/O Modules)	4 inputs	
	Minimum pulse width	30 μs	30 μs	
Interrupt Inputs	Number of inputs	8 inputs (4 × 2 Pulse I/O Modules)	4 inputs	
	Input response time	ON response time: 30 μs max. OFF response time: 150 μs max.	ON response time: 30 μs max. OFF response time: 150 μs max.	
	Interrupt modes	Direct Mode and Counter Mode	Direct Mode and Counter Mode	
	Software latching for PVs of high-speed counters and pulse outputs when an interrupt occurs	Supported.	Not supported.	
	Differences in operation	Update method for interrupt counter SV (Counter Mode)	Updating interrupt counter SV in Auxiliary Area and then executing MSKS(690) again to enable interrupts	Updating interrupt counter SV in Auxiliary Area
		Update method for interrupt counter PV (Counter Mode)	INI(880) instruction	<ul style="list-style-type: none"> INI(880) instruction Updating interrupt counter PV in Auxiliary Area
		Update timing for interrupt counter PV (Counter Mode)	<ul style="list-style-type: none"> Every cycle When count completion interrupt occurs When PRV(881) instruction is executed 	<ul style="list-style-type: none"> Once per count When PRV(881) instruction is executed
		Operation of interrupt counters when interrupts are disabled with DI(693)	Counter operation continued, but interrupt will not occur at count completion	Counter operation not continued.

Item		Specification/performance	
		CJ2M with Pulse I/O Module	CJ1M built-in I/O
High-speed counters	Differential-phase inputs	4 counters (2 × 2 Pulse I/O Modules) Line driver: 50 kHz (×4) 24-VDC power supply pulse: 35 kHz (×4)	2 counters Line driver: 50 kHz (×4) 24-VDC power supply pulse: 30 kHz (×4)
	Up input	4 counters Line driver: 100 kHz 24-VDC power supply pulse: 100 kHz	4 counters Line driver: 100 kHz 24-VDC power supply pulse: 60 kHz
	Up/down inputs or pulse + direction inputs	4 counters Line driver: 100 kHz 24-VDC power supply pulse: 100 kHz	2 counters Line driver: 100 kHz 24-VDC power supply pulse: 60 kHz
	Comparison methods	Target value comparison Number of target values: 48 Range comparison Number of ranges: 8 or 32 Interrupt task execution condition: Entering or leaving range.	Target value comparison Number of target values: 48 Range comparison Number of ranges: 8 Interrupt task execution condition: Entering range.
	Counting modes	Linear mode or ring mode	Linear mode or ring mode
	Numeric range	32 bits (-2,147,483,648 to +2,147,483,647) (0 to +4,294,967,295)	32 bits (-2,147,483,648 to +2,147,483,647) (0 to +4,294,967,295)
	Changing the ring counter maximum value	<ul style="list-style-type: none"> PLC Setup (when power is turned ON) When INI(880) instruction is executed 	PLC Setup (when power is turned ON)
Differences in operation	Operation of instruction to read frequencies (PRV(881)) and pulse frequency conversion instruction	If high-frequency mode is selected and the PV is changed or reset during a sampling interval, the results of the instruction will not be dependable and the P_CY Flag will turn ON.	If high-frequency mode is selected and the PV is changed or reset during a sampling interval, the results of the instruction will not be dependable.
	Handling of error when changing the PV in Ring Mode	If the new PV exceeds the ring counter maximum value, the P_ER Flag will turn ON when the instruction is executed.	If the new PV exceeds the ring counter maximum value, the instruction will be ignored.

Item		Specification/performance	
		CJ2M with Pulse I/O Module	CJ1M built-in I/O
Pulse output	Number of control axes	4 axes (2 × 2 Pulse I/O Modules)	2 axes
	Pulse output method	CW/CCW or Pulse + direction	CW/CCW or Pulse + direction
	Numeric range	32 bits (−2,147,483,648 to +2,147,483,647) (0 to +4,294,967,295)	32 bits (−2,147,483,648 to +2,147,483,647) (0 to +4,294,967,295)
	Output frequency	1 pps to 100 kpps	1 pps to 100 kpps
	Acceleration/deceleration control	Trapezoidal (linear or S-curve)	Trapezoidal (linear or S-curve)
	Internal pulse control frequency	1 or 4 ms (Set in the PLC Setup.)	4 ms
	Defining the origin	Origin search with ORG(889) instruction Changing PV with INI(880) instruction	Origin search with ORG(889) instruction Changing PV with INI(880) instruction
	Changing origin search parameters	<ul style="list-style-type: none"> PLC Setup (when power is turned ON) When INI(880) instruction is executed 	PLC Setup (when power is turned ON)
	Interrupt feeding	<ul style="list-style-type: none"> Combining ACC(888) + PLS2(887) instructions IFEED(892) instruction 	Combining ACC(888) + PLS2(887) instructions
	Monitoring output frequencies	Trend monitoring of output frequencies with the data trace function of the CX-Programmer	Reading output frequencies with PRV(881) instruction
Differences in operation	Actual output frequency	Integer division of 33.33 MHz	Integer division of 20 MHz
	Update timing for PLC Setup	Update timing for origin detection method: When power is turned ON	Update timing for origin detection method: When operation is started
	Allocation of I/O terminals	If not using the origin search is specified, unused terminals can be used for other functions depending on the operation mode.	If not using the origin search is specified, unused terminals cannot be used for other functions regardless of the operation mode
PWM outputs	Number of outputs	4 outputs (2 × 2 Pulse I/O Modules)	2 outputs
	Output frequency, duty ratio	<ul style="list-style-type: none"> 0.1 to 6,553.5 Hz, 0% to 100% 0.1 to 6,553.5 Hz, 0.0% to 100.0% 1 to 32,800 Hz, 0.0% to 100.0% 	<ul style="list-style-type: none"> 0.1 to 6,553.5 Hz, 0% to 100% 0.1 to 6,553.5 Hz, 0.0% to 100.0%
	Output accuracy	ON duty: +2%, −0% For 1-kHz, 0.5 mA output	ON duty: +5%, −0% For 1-kHz, 0.5 mA output
Differences in operation	Actual output frequency	Integer division of 33.33 MHz	Integer division of 20 MHz
	Timing of stopping output for INI(880) instruction	Output stopped immediately when INI(880) instruction is executed.	Output stopped one pulse period after INI(880) instruction is executed.

A-4 Performance Information



Precautions for Correct Use

The actual performance depends on a variety of factors that affect CPU Unit operation such as the function's operating conditions, user program complexity, and cycle time. Use the performance specifications as guidelines, not absolute values.

A-4-1 Interrupt Input Response Time

The interrupt response time is the time it takes between an OFF-to-ON signal (or ON-to-OFF signal for down-differentiation) at the interrupt input terminal until the corresponding I/O interrupt task is actually executed. The total response time is the sum of the hardware response time and software response time.

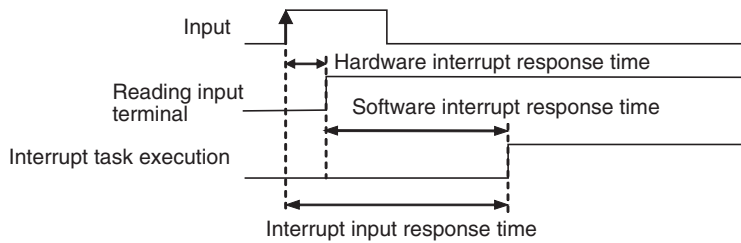

Interrupt response time = Hardware interrupt response time + Software interrupt response time

Hardware Interrupt Response Time

Edge direction	Interrupt response time
Rising edge	30 μs
Falling edge	150 μs

Software Interrupt Response Time

Interrupt type	Interrupt response time
Interrupt inputs in Direct Mode	33 μs min.
Interrupt inputs in Counter Mode	34 μs min.

A-4-2 Pulse Output Start Time

The pulse output start time is the time required from executing a pulse output instruction until pulses are output externally. This time depends on the pulse output instruction that is used and operation that is performed.

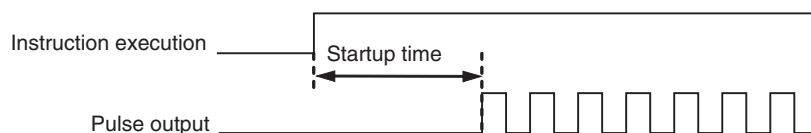

Pulse output instruction	Startup time
SPED(885), continuous	23 μs
SPED(885), independent	24 μs
ACC(888), continuous	31 μs
ACC(888), independent, trapezoidal	33 μs
ACC(888), independent, triangular	39 μs
PLS2(887), trapezoidal	35 μs
PLS2(887), triangular	42 μs
IFEED(892)	34 μs

A-4-3 Response Times of Pulse Output Changes

The pulse output change response time is the time for any change made by executing an instruction during pulse output to actually affect the pulse output operation.

Pulse output instruction	Change response time
INI(880,) immediate stop	10 μs + 1 pulse output time
SPED(885), immediate stop	14 μs + 1 pulse output time
ACC(888), deceleration stop	Between 1 and 2 pulse control cycles
PLS2(887), deceleration stop	
SPED(885), speed change	
ACC(888), speed change	
PLS2(887), target position change in reverse direction	
PLS2(887), target position change in same direction at same speed	
PLS2(887), target position change in same direction at different speed	

Note: The pulse control cycle is set in the PLC Setup to either 1 ms or 4 ms.

Index

A	
absolute coordinates	8-28
absolute positioning	8-28
ACC(888)	8-24
allocating functions	
input terminals	2-5
output terminals	2-7
PLC Setup	2-4
setting method	2-4
B	
base settings	2-12
C	
cables	
wiring with self-made cable	3-15
connector pin allocations	3-7
Connector-Terminal Block Conversion Units	3-9
Counter Mode	6-4
CTBL(882)	7-28
D	
differential phase inputs	7-13
Direct Mode	6-4
G	
gate function	7-20
H	
high-speed counter interrupts	7-21
MODE CONTROL Instruction (INI(880))	7-31
PLC Setup	7-23
present value comparison	7-25
programming	7-24
REGISTER COMPARISON TABLE (CTBL(882)) instruction	7-28
high-speed counters	7-1
application examples	7-43
Auxiliary Area	7-35
counting mode setting	7-14
frequency measurement	7-17
gate function	7-20
input specifications	3-3
linear mode	7-14
measuring rotational speed or total revolutions	7-18
PLC Setup	7-4
pulse input methods	7-13
range comparison	7-22
reading count direction	7-19
reading present value	7-16
reset methods	7-16
setting	2-10
specifications	7-3
target value comparison	7-22
wiring	7-7
high-speed jogging	8-32
I	
I/O circuits	
configuration	3-8
I/O specifications	3-2
IFEED(892)	8-37
increment pulse input	7-13
INI(880)	7-31, 8-24, 8-44, 9-5
input specifications	3-2
interrupt feeding	8-35
INTERRUPT FEEDING instruction (IFEED(892))	8-37
PLC Setup	8-36
interrupt inputs	6-3
Auxiliary Area	6-13
PLC Setup	6-6
programming	6-10
setting	2-9
specifications	3-2, 6-5
wiring	6-10
interrupt inputs and quick-response inputs	
setting	2-9
interrupts	
interrupt inputs	6-3
types	6-2
J	
jogging	8-32
L	
low-speed jogging	8-32
M	
manual operation	
jogging	8-32
MSKS(690)	6-11
N	
normal inputs	4-2
setting	2-9
specifications	3-2, 4-4
wiring	4-7
normal outputs	4-5
specifications	3-4, 3-5, 4-6
wiring	4-8

O

ORG(889)	8-24, 8-45, 8-51
origin	
defining	8-39
origin returns	2-14, 8-51
ORIGIN SEARCH instruction (ORG(889))	8-45
origin searches	2-13, 8-39
operation modes	8-46
origin returns	8-51
ORIGIN SEARCH instruction (ORG(889))	8-51
setting	2-11
OUT instruction	8-25
output specifications	3-4, 3-5

P

phase-Z signal + software reset	7-16
PLC Setup	2-8
high-speed counters	2-10
interrupt inputs and quick-response inputs	2-9
normal inputs	2-9
pulse outputs and origin searches	2-11
PLS2(887)	8-27
position control	8-27
independent mode	8-89
origin searches	8-39
S-curve acceleration/deceleration	8-28
present value comparison	7-25
PRV(881)	6-12, 8-24
reading high-speed counter frequency	7-18
reading high-speed counter PV	7-17
reading high-speed counter status	7-20
reading pulse output PV	8-56, 8-57
PRV2(883)	
measuring rotational speed or total rotations	7-18
pulse + direction inputs	7-14
pulse I/O	
functions	1-6
pulse input methods	7-13
pulse outputs	8-1
application example	8-63
Auxiliary Area	8-58
changing PV	8-51
defining origin	8-39
external sensor connections	8-13
jogging	8-32
ladder program	8-24
output patterns	8-87
PLC Setup	8-6
position control	8-27
position control (independent mode)	8-89
precautions	8-82
pulse control instructions	8-24
reading frequency	8-57
reading PV	8-56
Servo Drive connections	8-13
setting	2-11
specifications	3-4, 3-5, 8-5
speed control (continuous mode)	8-87
starting	8-87
stopping	8-88
wiring	8-11
PWM outputs	9-2

flag operations	A-2
instruction combinations	A-3
specifications	3-6, 9-4
wiring	9-4
PWM(891)	9-5

Q

quick-response inputs	5-1
PLC Setup	5-3
programming	5-7
setting	2-9
specifications	3-2
wiring	5-6

R

range comparison	7-27
relative coordinates	8-28
relative positioning	8-28
ring counter maximum value	7-15
ring mode	
high-speed counter	7-15

S

Servo Relay Units	3-11
software latches	6-8
software reset	7-16
speed control	
continuous mode	8-87

U

up/down pulse inputs	7-13
----------------------	------

V

variable duty ratio pulse outputs (PWM outputs)	9-2
---	-----

W

wiring	3-7
normal inputs	4-7
normal outputs	4-8
using a self-made cable	3-15
using Connector-Terminal Block Conversion	
Units	3-9
using Servo Relay Units	3-11

Revision History

A manual revision code appears as a suffix to the catalog number on the front cover of the manual.

Cat. No. W486-E1-01

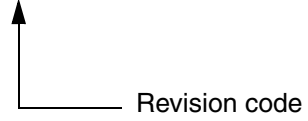

The following table outlines the changes made to the manual during each revision. Page numbers refer to the previous version.

Revision code	Date	Revised content
01	July 2010	Original production

OMRON Corporation Industrial Automation Company

Tokyo, JAPAN

Contact: www.ia.omron.com

Regional Headquarters

OMRON EUROPE B.V.

Wegalaan 67-69-2132 JD Hoofddorp
The Netherlands

Tel: (31)2356-81-300/Fax: (31)2356-81-388

OMRON ASIA PACIFIC PTE. LTD.

No. 438A Alexandra Road # 05-05/08 (Lobby 2),
Alexandra Technopark,
Singapore 119967

Tel: (65) 6835-3011/Fax: (65) 6835-2711

OMRON ELECTRONICS LLC

One Commerce Drive Schaumburg,
IL 60173-5302 U.S.A.

Tel: (1) 847-843-7900/Fax: (1) 847-843-7787

OMRON (CHINA) CO., LTD.

Room 2211, Bank of China Tower,
200 Yin Cheng Zhong Road,
PuDong New Area, Shanghai, 200120, China

Tel: (86) 21-5037-2222/Fax: (86) 21-5037-2200

Authorized Distributor:

© OMRON Corporation 2010 All Rights Reserved.
In the interest of product improvement,
specifications are subject to change without notice.

Cat. No. W486-E1-01

0710

Below is a list of articles with direct links to our shop Electric Automation Network where you can see:

- Quote per purchase volume in real time.
- Online documentation and datasheets of all products.
- Estimated delivery time enquiry in real time.
- Logistics systems for the shipment of materials almost anywhere in the world.
- Purchasing management, order record and tracking of shipments.

To access the product, [click on the green button.](#)

Product	Code	Reference	Product link
Control System, Module 16 inputs 24 VDC Screwless	171731	CJ1W-ID211	Buy on EAN
Control System, Module E / S Pulse NPN CJ2M	341746	CJ2M-MD211	Buy on EAN
Control System, Module E / S PNP Pulses for CJ2M	341747	CJ2M-MD212	Buy on EAN
Control System, Module 16 24Vdc inputs Term.	382929	CJ1W-ID211	Buy on EAN
Motion Control, Cable XW2B-xxJE-Xa a Junma 1m	231790	XW2Z-100J-B17	Buy on EAN
Motion Control, Cable CJ1M-CPU22/23 a Terminal pasivo SmartStep 1m	107453	XW2Z-100J-A26	Buy on EAN
Servos, Cable terminal pasivo a servodrive SS2 (100-400w) 2m	292072	XW2Z-200J-B32	Buy on EAN
Servos, Cable terminal pasivo a servodrive SS2 (100-400w) 1m	292071	XW2Z-100J-B32	Buy on EAN
Motion Control, Terminal Cable 1m passive Sigma II	107500	XW2Z-100J-B4	Buy on EAN
Control system, connector block 40 I / S Slim	374213	XW2D-40G6	Buy on EAN