



Electric Automation
Automation specialists

Reference: JSM D15
Code: 2TLA040033R3900

JSM D15 Cam lock exkl. key Polyamid
black

Buy it at [Electric Automation Network](#)

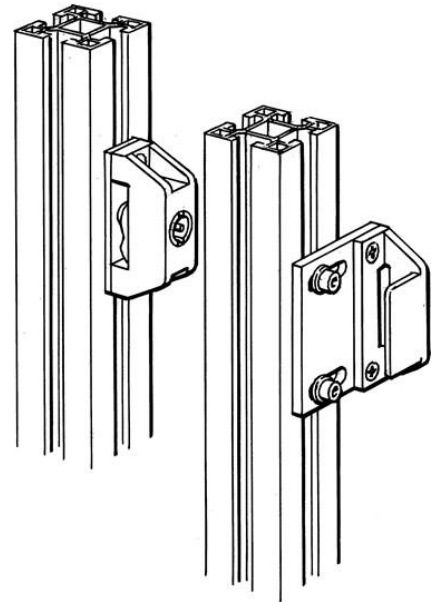

Cam lock including. fitting. Bracket are in Aluminium and Lockunit in black Polymide.
Keys are excluded.

Ordering

EAN:	7350024462326
Minimum Order Quantity:	1 piece
Customs Tariff Number:	76109090

Dimensions

Product Net Width:	0.082 m
Product Net Height:	0.07 m
Product Net Depth:	0.035 m
Product Net Weight:	0.213 kg

Container Information

Package Level 1 Units:	1 piece
Package Level 1 Gross Weight:	0.213 kg

Additional Information

Product Main Type:	Quick-Guard
Product Name:	Safety Fencing Systems Quick Guard

Certificates and Declarations (Document Number)

Data Sheet, Technical Information:	2TLC172001C0202_chapter13
Declaration of Conformity - CE:	NoDecNee

Classifications

ETIM 4:	EC002626 - Component for door (switchgear cabinet)
ETIM 5:	EC002783 - Accessories for safety equipment
Object Classification Code:	X