



Electric Automation
Automation specialists

Reference: DALTON KIT 5
Code: 2TLA020039R0400

Dalton bracket 5

Buy it at Electric Automation Network

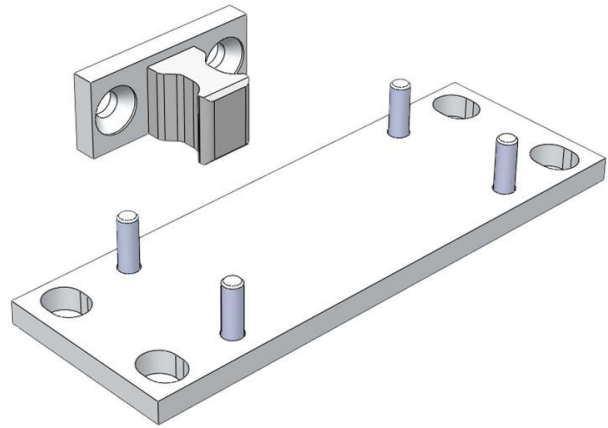

Fixing plate for Dalton, small bracket for lock tongue.

Ordering

EAN:	7350024459166
Minimum Order Quantity:	1 piece
Customs Tariff Number:	76169990

Dimensions

Product Net Width:	0.08 m
Product Net Height:	0.05 m
Product Net Depth:	0.065 m
Product Net Weight:	0.074 kg

Container Information

Package Level 1 Units:	1 piece
Package Level 1 Width:	0.10 m
Package Level 1 Height:	0.05 m
Package Level 1 Length:	0.17 m
Package Level 1 Gross Weight:	0.074 kg

Additional Information

Product Main Type:	Dalton Accessory
--------------------	------------------

Product Name:	Bracket
---------------	---------

Certificates and Declarations (Document Number)

Data Sheet, Technical Information:	2TLC172001C0202_chapter09
Declaration of Conformity - CE:	2TLC172084D0201

Classifications

ETIM 4:	EC002594 - Accessories for position switches
ETIM 5:	EC002594 - Accessories for position switches
Object Classification Code:	U